

A4D450-AO14-12 ebmpapst Datasheet

sales@fansco.com

www.fansco.com

Limited partnership · Headquarters Mulfingen

Amtsgericht (court of registration) Stuttgart · HRA 590344

General partner Elektrobau Mulfingen GmbH · Headquarters Mulfingen

Amtsgericht (court of registration) Stuttgart · HRB 590142

Nominal data

Type	A4D450-AO14-12				
Motor	M4D094-HA				
Phase		3~	3~	3~	3~
Nominal voltage	VAC	400	400	400	400
Wiring		Δ	Y	Δ	Y
Frequency	Hz	50	50	60	60
Method of obtaining data		ml	ml	ml	ml
Valid for approval/standard		CE	CE	CE	CE
Speed (rpm)	min ⁻¹	1360	1110	1510	1060
Power consumption	W	480	340	690	400
Current draw	A	0.98	0.58	1.2	0.72
Max. back pressure	Pa	140	90	145	70
Max. back pressure	in. wg	0.56	0.36	0.58	0.28
Min. ambient temperature	°C	-40	-40	-40	-40
Max. ambient temperature	°C	65	65	50	50
Starting current	A	3.9	1.3	3.5	1.2

ml = Max. load · me = Max. efficiency · fa = Free air · cs = Customer specification · ce = Customer equipment
Subject to change

Data according to Commission Regulation (EU) 327/2011

		Actual	Req. 2015		
01 Overall efficiency η_{es}	%	35.4	31.5	09 Power consumption P_e	kW 0.46
02 Measurement category		A		09 Air flow q_v	m ³ /h 4530
03 Efficiency category		Static		09 Pressure increase p_{fs}	Pa 133
04 Efficiency grade N		43.9	40	10 Speed (rpm) n	min ⁻¹ 1365
05 Variable speed drive		No		11 Specific ratio*	1.00

Data obtained at optimum efficiency level.
The ErP data is determined using a motor-impeller combination in a standardized measurement setup.

* Specific ratio = $1 + p_{fs} / 100\,000\text{ Pa}$

LU-107893



Technical description

Weight	7 kg
Size	450 mm
Motor size	94
Rotor surface	Painted black
Terminal box material	PP plastic
Blade material	Press-fitted sheet steel blank, sprayed with PP plastic
Number of blades	5
Airflow direction	A
Direction of rotation	Clockwise, viewed toward rotor
Degree of protection	IP54
Insulation class	"F"
Moisture (F) / Environmental (H) protection class	H2
Ambient temperature note	Occasional start-up at temperatures between -40°C and -25°C is permitted. For continuous operation at ambient temperatures below -25°C (such as refrigeration applications), use must be made of a fan design with special low-temperature bearings.
Max. permitted ambient temp. for motor (transport/storage)	+80 °C
Min. permitted ambient temp. for motor (transport/storage)	-40 °C
Installation position	Shaft horizontal or rotor on top; rotor on bottom on request
Condensation drainage holes	On stator side
Mode	S1
Motor bearing	Ball bearing
Touch current according to IEC 60990 (measuring circuit Fig. 4, TN system)	<= 3.5 mA
Electrical hookup	Terminal box
Motor protection	Thermal overload protector (TOP) with basic insulation
Protection class	I (with customer connection of protective earth)
Conformity with standards	EN 60034-1 (2010); CE
Approval	EAC

AC axial fan

sickle-shaped blades (S series)

Product drawing

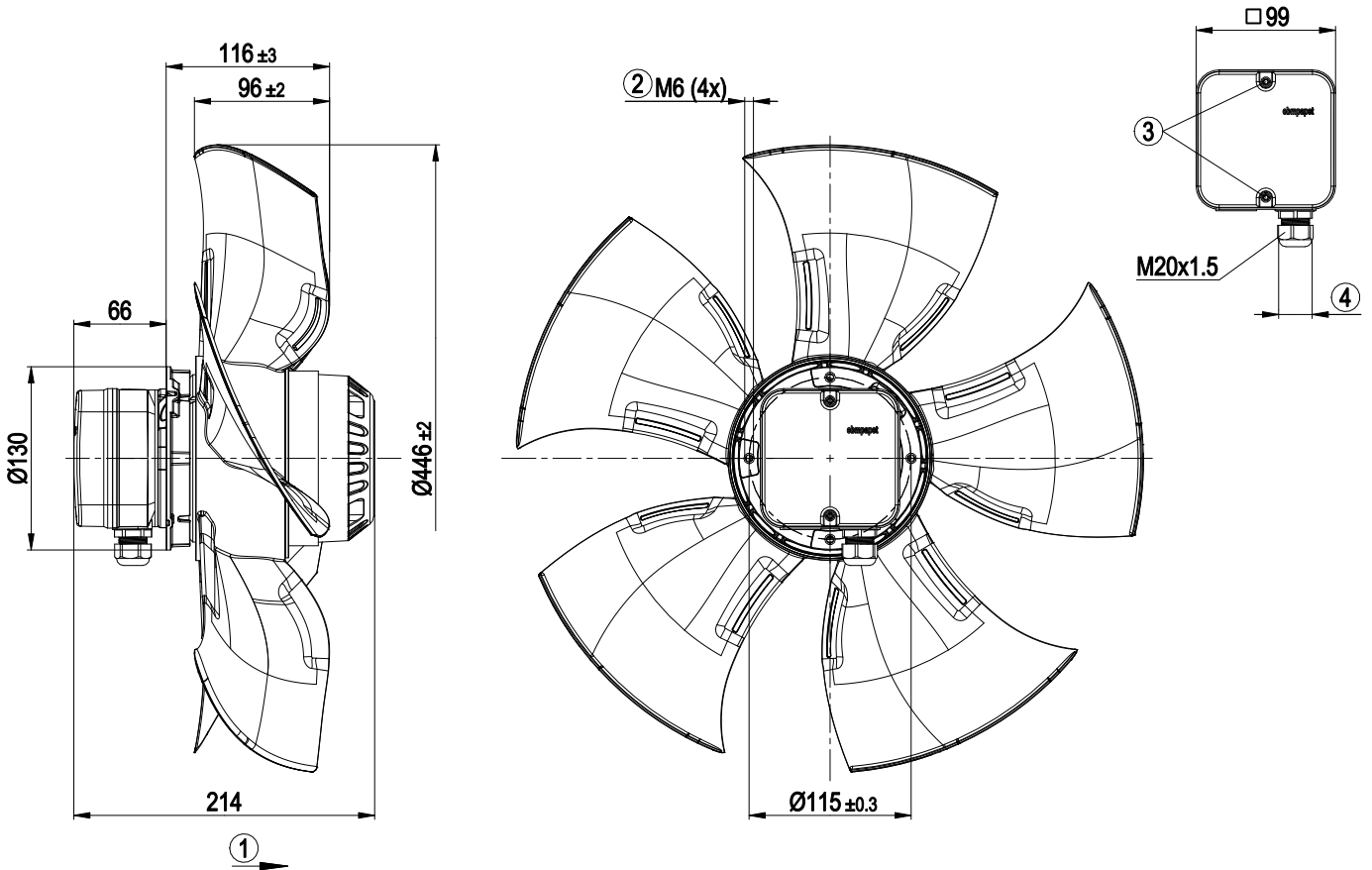

1	Direction of air flow "A"
2	Max. clearance for screw 12 mm
3	Tightening torque 1.5 ± 0.2 Nm
4	Cable diameter min. 6 mm, max. 12 mm, tightening torque 2 ± 0.3 Nm



Connection diagram

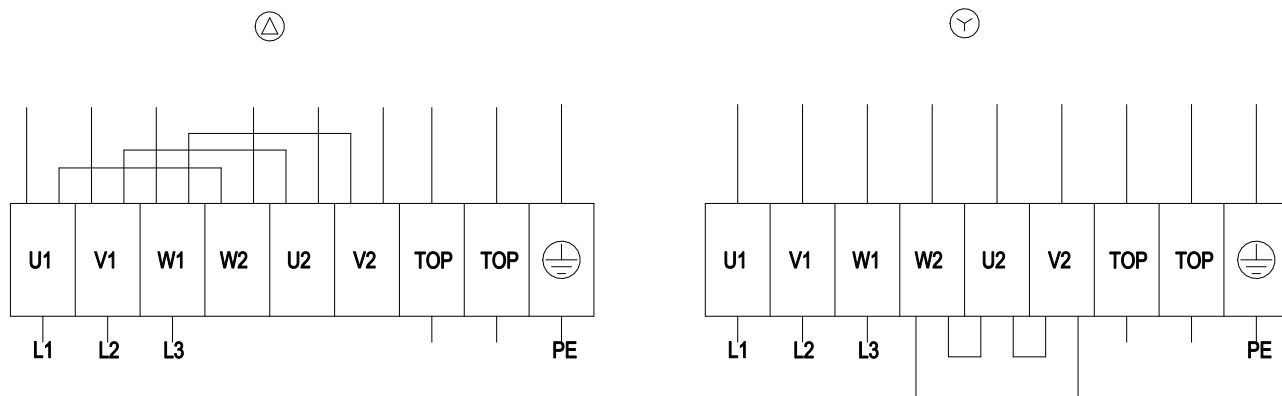

Δ	Delta connection	Y	Star connection	L1	= U1 = black
L2	= V1 = blue	L3	= W1 = brown	W2	yellow
U2	green	V2	white	TOP	2x gray
PE	green/yellow				

Curves: Air performance 50 Hz

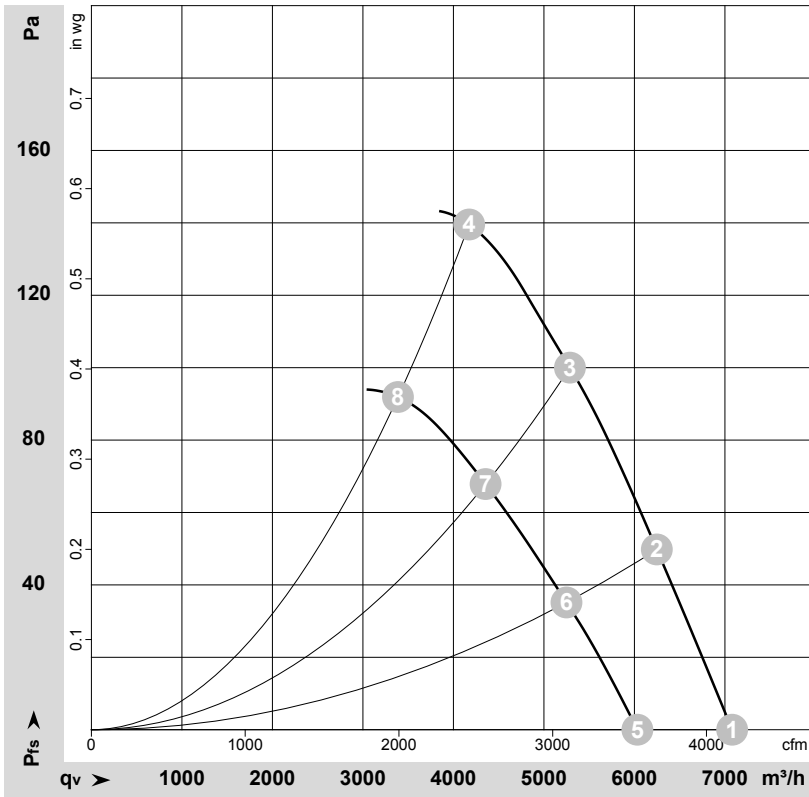

$\rho = 1.19 \text{ kg/m}^3 \pm 2 \%$

Measurement: LU-107893-1
Measurement: LU-107309-1

Air performance measured according to ISO 5801 installation category A. For detailed information on the measurement setup, contact ebm-papst. Intake sound level: Sound power level according to ISO 13347 / sound pressure level measured at 1 m distance from fan axis. The values given are valid under the specified measuring conditions and may vary due to conditions of installation. For deviations from the standard configuration, the parameters have to be checked on the installed unit.

Measured values

	Wired	U	f	n	P _e	I	LpA _{in}	LwA _{in}	LwA _{out}	q _v	P _{fs}	q _v	P _{fs}
		V	Hz	min ⁻¹	W	A	dB(A)	dB(A)	dB(A)	m ³ /h	Pa	cfm	in. wg
1	Δ	400	50	1400	386	0.88	65	71	72	7080	0	4165	0.00
2	Δ	400	50	1385	423	0.91	62	68	69	6250	50	3675	0.20
3	Δ	400	50	1370	456	0.95	61	68	68	5290	100	3110	0.40
4	Δ	400	50	1360	480	0.98	63	69	70	4175	140	2455	0.56
5	Y	400	50	1195	285	0.49				6035	0	3550	0.00
6	Y	400	50	1155	309	0.52				5250	35	3090	0.14
7	Y	400	50	1130	328	0.55				4355	68	2565	0.27
8	Y	400	50	1110	340	0.58				3385	92	1995	0.37

Wired = Wiring · U = Voltage · f = Frequency · n = Speed (rpm) · P_e = Power consumption · I = Current draw · LpA_{in} = Sound pressure level intake side · LwA_{in} = Sound power level intake side
LwA_{out} = Sound power level outlet side · q_v = Air flow · P_{fs} = Pressure increase



Curves: Air performance 60 Hz

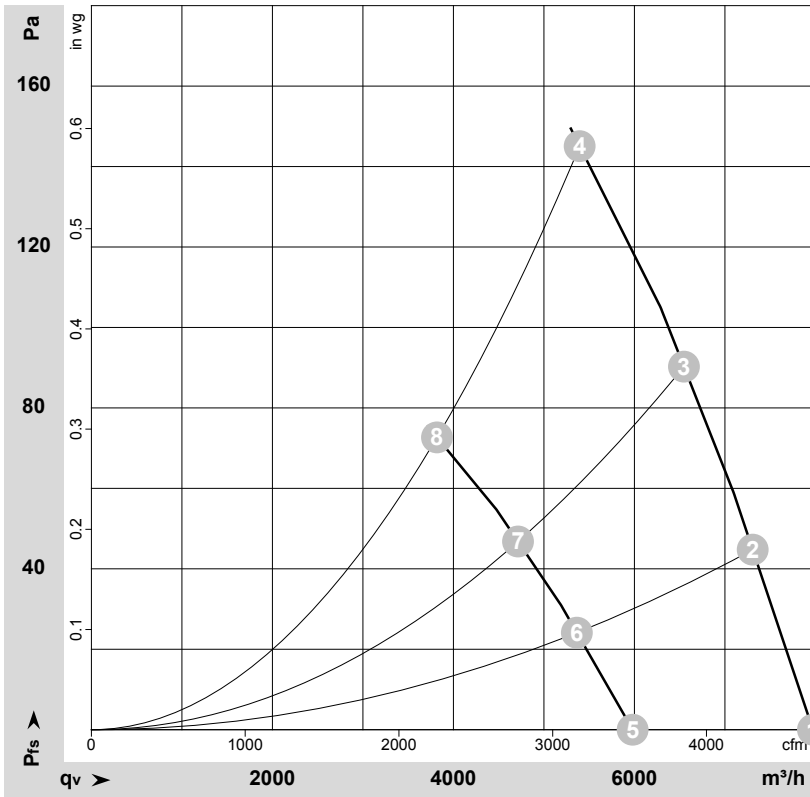

$\rho = 1.189 \text{ kg/m}^3 \pm 2 \%$

Measurement: LU-108207-1
Measurement: LU-108206-1

Air performance measured according to ISO 5801 installation category A. For detailed information on the measurement setup, contact ebm-papst. Intake sound level: Sound power level according to ISO 13347 / sound pressure level measured at 1 m distance from fan axis. The values given are valid under the specified measuring conditions and may vary due to conditions of installation. For deviations from the standard configuration, the parameters have to be checked on the installed unit.

Measured values

	Wired	U	f	n	P _e	I	LpA _{in}	LwA _{in}	LwA _{out}	q _v	P _{fs}	q _v	P _{fs}
		V	Hz	min ⁻¹	W	A	dB(A)	dB(A)	dB(A)	m ³ /h	Pa	cfm	in. wg
1	Δ	400	60	1570	580	1.03	67	73	74	7975	0	4695	0.00
2	Δ	400	60	1550	620	1.09	65	71	73	7305	45	4300	0.18
3	Δ	400	60	1530	657	1.15	64	70	71	6545	90	3855	0.36
4	Δ	400	60	1510	690	1.20	64	70	71	5395	145	3175	0.58
5	Y	400	60	1175	375	0.65	62	67	68	5980	0	3520	0.00
6	Y	400	60	1130	388	0.68	59	65	65	5365	24	3155	0.10
7	Y	400	60	1095	398	0.70	57	63	63	4715	47	2775	0.19
8	Y	400	60	1060	400	0.72	56	62	62	3820	73	2245	0.29

Wired = Wiring · U = Voltage · f = Frequency · n = Speed (rpm) · P_e = Power consumption · I = Current draw · LpA_{in} = Sound pressure level intake side · LwA_{in} = Sound power level intake side
LwA_{out} = Sound power level outlet side · q_v = Air flow · P_{fs} = Pressure increase

