

A4D450-AO10-03 ebmpapst Datasheet

sales@fansco.com

www.fansco.com

Limited partnership · Headquarters Mulfingen

Amtsgericht (court of registration) Stuttgart · HRA 590344

General partner Elektrobau Mulfingen GmbH · Headquarters Mulfingen

Amtsgericht (court of registration) Stuttgart · HRB 590142

Nominal data

Type	A4D450-AO10-03					
Motor	M4D094-HA					
Phase		3~	3~	3~	3~	3~
Nominal voltage	VAC	230	230	400	400	460
Wiring		Δ	Δ	Y	Y	Y
Frequency	Hz	50	60	50	60	60
Method of obtaining data		ml	ml	ml	ml	ml
Valid for approval/standard		CE	CE	CE	CE	CE
Speed (rpm)	min ⁻¹	1370	1520	1370	1520	1600
Power consumption	W	455	695	455	695	710
Current draw	A	1.77	2.15	1.02	1.24	1.15
Max. back pressure	Pa	120	150	120	150	110
Max. back pressure	in. wg	0.48	0.6	0.48	0.6	0.44
Min. ambient temperature	°C	-25	-25	-25	-25	-25
Max. ambient temperature	°C	65	60	65	60	65
Starting current	A	7.0	6.4	4	3.7	

ml = Max. load · me = Max. efficiency · fa = Free air · cs = Customer specification · ce = Customer equipment
Subject to change

Data according to Commission Regulation (EU) 327/2011 (EN 17166)

		Actual	Req. 2015		
01 Overall efficiency η_{es}	%	33.9	31.5	09 Power consumption P_e	kW 0.45
02 Measurement category	A			09 Air flow q_v	m ³ /h 4530
03 Efficiency category	Static			09 Pressure increase p_{fs}	Pa 124
04 Efficiency grade N	42.4	40		10 Speed (rpm) n	min ⁻¹ 1375
05 Variable speed drive	No			11 Specific ratio*	1.00

Data obtained at optimum efficiency level.
The ErP data is determined using a motor-impeller combination in a standardized measurement setup.

* Specific ratio = $1 + p_{fs} / 100\,000\text{ Pa}$

LU-111305



Technical description

Weight	7.12 kg
Size	450 mm
Motor size	94
Rotor surface	Painted black
Terminal box material	PP plastic
Blade material	Press-fitted sheet steel blank, sprayed with PP plastic
Number of blades	5
Airflow direction	A
Direction of rotation	Clockwise, viewed toward rotor
Degree of protection	IP54
Insulation class	"F"
Moisture (F) / Environmental (H) protection class	H2
Max. permitted ambient temp. for motor (transport/storage)	+80 °C
Min. permitted ambient temp. for motor (transport/storage)	-40 °C
Installation position	Shaft horizontal or rotor on bottom; rotor on top on request
Condensation drainage holes	On rotor side
Mode	S1
Motor bearing	Ball bearing
Touch current according to IEC 60990 (measuring circuit Fig. 4, TN system)	<= 3.5 mA
Electrical hookup	Terminal box
Motor protection	Thermal overload protector (TOP) with basic insulation
Protection class	I (with customer connection of protective earth)
Conformity with standards	EN 60034-1 (2010); CE
Approval	CSA C22.2 No. 100; UL 1004-1; EAC

AC axial fan - HyBlade

sickle-shaped blades (S series)

Product drawing

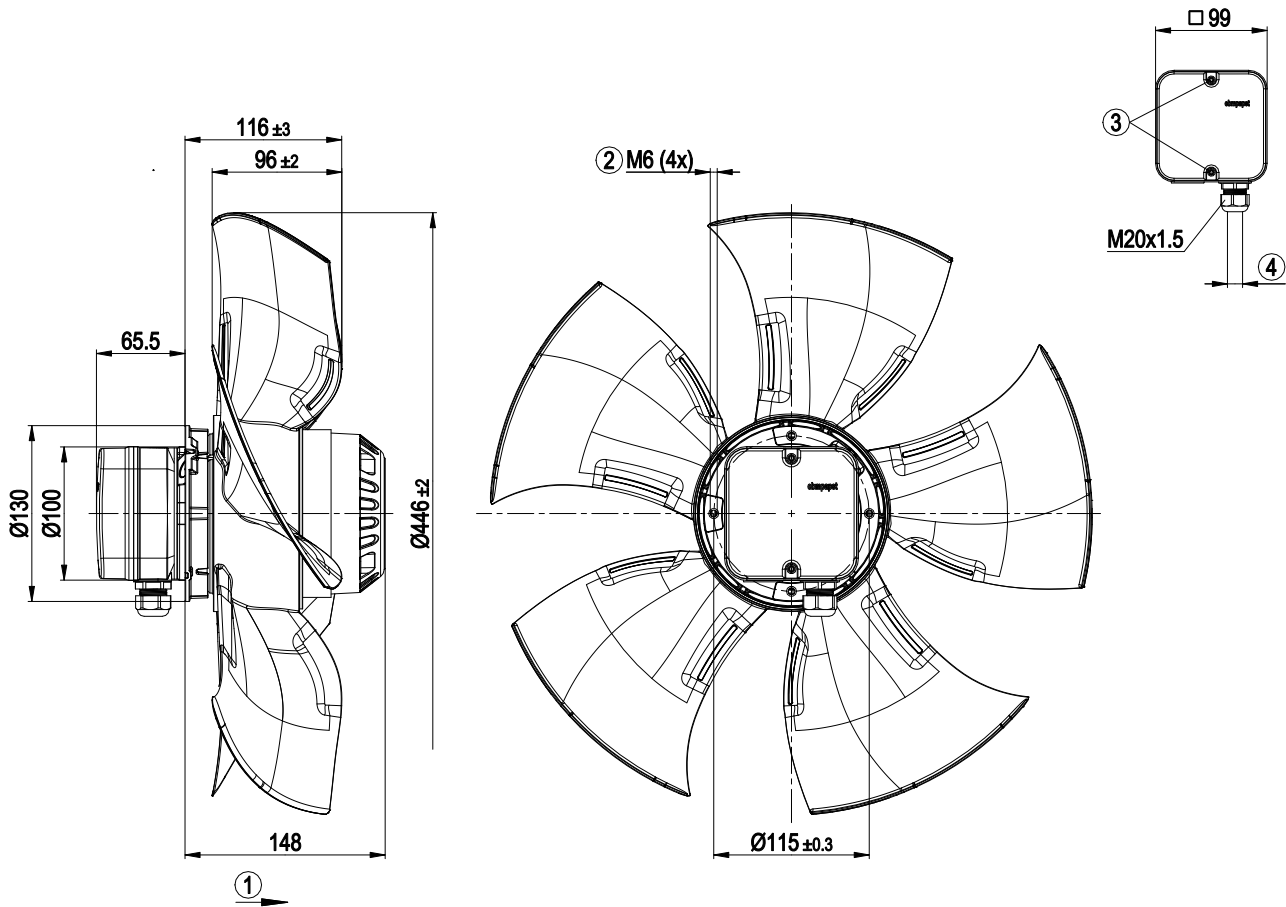

1	Direction of air flow "A"
2	Max. clearance for screw 12 mm
3	Tightening torque 1.5 ± 0.2 Nm
4	Cable diameter min. 6 mm, max. 12 mm, tightening torque 2 ± 0.3 Nm



AC axial fan - HyBlade

sickle-shaped blades (S series)

Connection diagram



Δ	Delta connection	Y	Star connection	L1	= U1 = black
L2	= V1 = blue	L3	= W1 = brown	W2	yellow
U2	green	V2	white	TOP	2x gray
PE	green/yellow				



Curves: Air performance 50 Hz

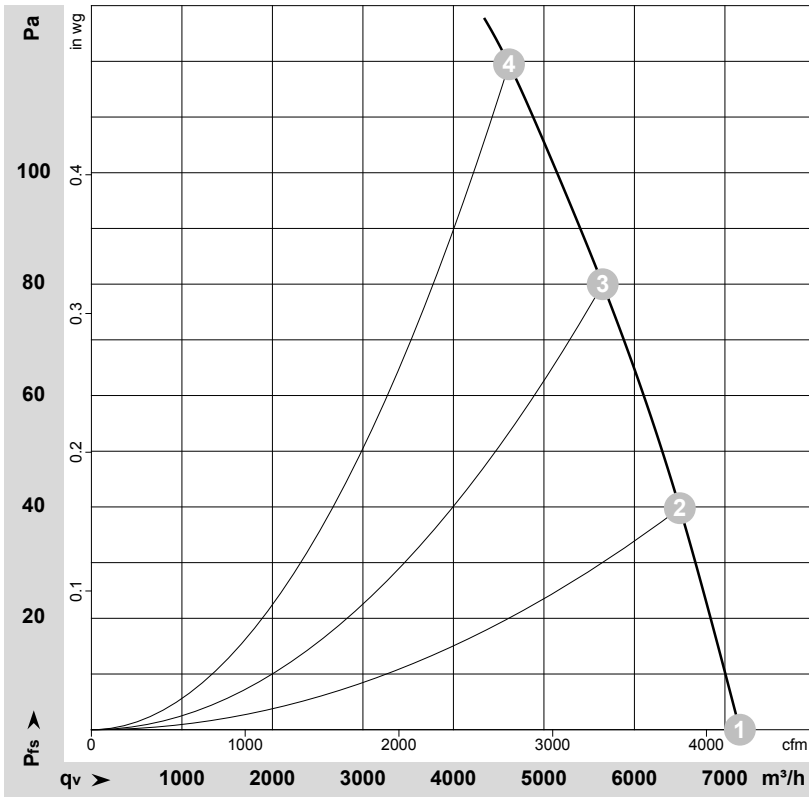

$\rho = 1.15 \text{ kg/m}^3 \pm 2 \%$

Measurement: LU-111305-1

Air performance measured according to ISO 5801 installation category A. For detailed information on the measurement setup, contact ebmpapst. Intake sound level: Sound power level according to ISO 13347 / sound pressure level measured at 1 m distance from fan axis. The values given are valid under the specified measuring conditions and may vary due to conditions of installation. For deviations from the standard configuration, the parameters have to be checked on the installed unit.

Measured values

	Wired	U	f	n	P _e	I	LpA _{in}	LwA _{in}	LwA _{out}	q _v	p _{fs}	q _v	p _{fs}
		V	Hz	min ⁻¹	W	A	dB(A)	dB(A)	dB(A)	m ³ /h	Pa	cfm	in. wg
1	Y	400	50	1400	375	0.90	65	71	72	7165	0	4220	0.00
2	Y	400	50	1395	402	0.96	63	69	70	6500	40	3825	0.16
3	Y	400	50	1385	429	0.98	62	68	69	5650	80	3325	0.32
4	Y	400	50	1370	455	1.02	62	68	68	4615	120	2715	0.48

Wired = Wiring · U = Voltage · f = Frequency · n = Speed (rpm) · P_e = Power consumption · I = Current draw · LpA_{in} = Sound pressure level intake side · LwA_{in} = Sound power level intake side
 LwA_{out} = Sound power level outlet side · q_v = Air flow · p_{fs} = Pressure increase



Curves: Air performance 60 Hz

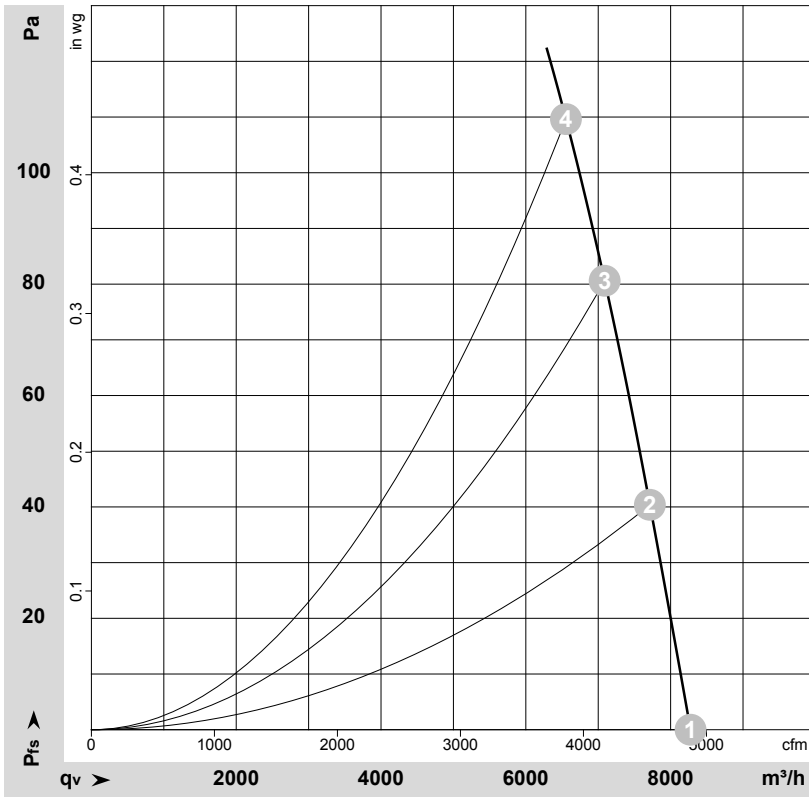

$\rho = 1.175 \text{ kg/m}^3 \pm 2 \%$

Measurement: LU-116995-1

Air performance measured according to ISO 5801 installation category A. For detailed information on the measurement setup, contact ebmpapst. Intake sound level: Sound power level according to ISO 13347 / sound pressure level measured at 1 m distance from fan axis. The values given are valid under the specified measuring conditions and may vary due to conditions of installation. For deviations from the standard configuration, the parameters have to be checked on the installed unit.

Measured values

	Wired	U	f	n	P _e	I	q _v	p _{fs}	q _v	p _{fs}
		V	Hz	min ⁻¹	W	A	m ³ /h	Pa	cfm	in. wg
1	Y	460	60	1640	606	1.03	8275	0	4870	0.00
2	Y	460	60	1615	653	1.09	7715	40	4540	0.16
3	Y	460	60	1605	681	1.12	7090	80	4170	0.32
4	Y	460	60	1600	710	1.15	6555	110	3860	0.44

Wired = Wiring · U = Voltage · f = Frequency · n = Speed (rpm) · P_e = Power consumption · I = Current draw · q_v = Air flow · p_{fs} = Pressure increase

