

A4D400-AP16-20 ebmpapst Datasheet

sales@fansco.com

www.fansco.com

Limited partnership · Headquarters Muldingen

Amtsgericht (court of registration) Stuttgart · HRA 590344

General partner Elektrobau Muldingen GmbH · Headquarters Muldingen

Amtsgericht (court of registration) Stuttgart · HRB 590142



Nominal data

Type	A4D400-AP16-20				
Motor	M4D074-EI				
Phase		3~	3~	3~	3~
Nominal voltage	VAC	400	400	400	400
Wiring		Δ	Y	Δ	Y
Frequency	Hz	50	50	60	60
Method of obtaining data		fa	fa	fa	fa
Valid for approval/standard		CE	CE	CE	CE
Speed (rpm)	min ⁻¹	1440	1300	1670	1360
Power consumption	W	170	115	210	160
Current draw	A	0.53	0.21	0.44	0.27
Max. back pressure	Pa	150	100	120	60
Max. back pressure	inH ₂ O	0.6	0.4	0.48	0.24
Min. ambient temperature	°C	-25	-25	-25	-25
Max. ambient temperature	°C	55	85	65	65

ml = Max. load · me = Max. efficiency · fa = Free air · cs = Customer specification · ce = Customer equipment

Subject to change

Data according to ErP Directive

		Actual	Req. 2015		
01 Overall efficiency η_{es}	%	31.6	29.5	09 Power consumption P_e	kW 0.22
02 Measurement category	A			09 Air flow q_v	m ³ /h 2610
03 Efficiency category	Static			09 Pressure increase p_{fs}	Pa 100
04 Efficiency grade N	42.1	40		10 Speed (rpm) n	min ⁻¹ 1400
05 Variable speed drive	No			11 Specific ratio*	1.00

Data obtained at optimum efficiency level.

The ErP data is determined using a motor-impeller combination in a standardized measurement setup.

* Specific ratio = $1 + p_g / 100\,000\text{ Pa}$

LU-43060



Technical description

Weight	4.27 kg
Fan size	400 mm
Rotor surface	Painted black
Blade material	Sheet steel, painted black
Number of blades	5
Airflow direction	"V"
Direction of rotation	Counterclockwise, viewed toward rotor
Degree of protection	IP44; installation- and position-dependent as per EN 60034-5
Insulation class	"F"
Moisture (F) / Environmental (H) protection class	H0+
Max. permitted ambient temp. for motor (transport/storage)	+ 80 °C
Min. permitted ambient temp. for motor (transport/storage)	- 40 °C
Installation position	Shaft horizontal or rotor on bottom; rotor on top on request
Condensation drainage holes	On rotor side
Mode	S1
Motor bearing	Ball bearing
Touch current according to IEC 60990 (measuring circuit Fig. 4, TN system)	< 0.75 mA
Motor protection	Thermal overload protector (TOP) with basic insulation
With cable	Variable
Protection class	I (with customer connection of protective earth)
Conformity with standards	EN 60335-1; CE

AC axial fan

sickle-shaped blades (S series)

Product drawing

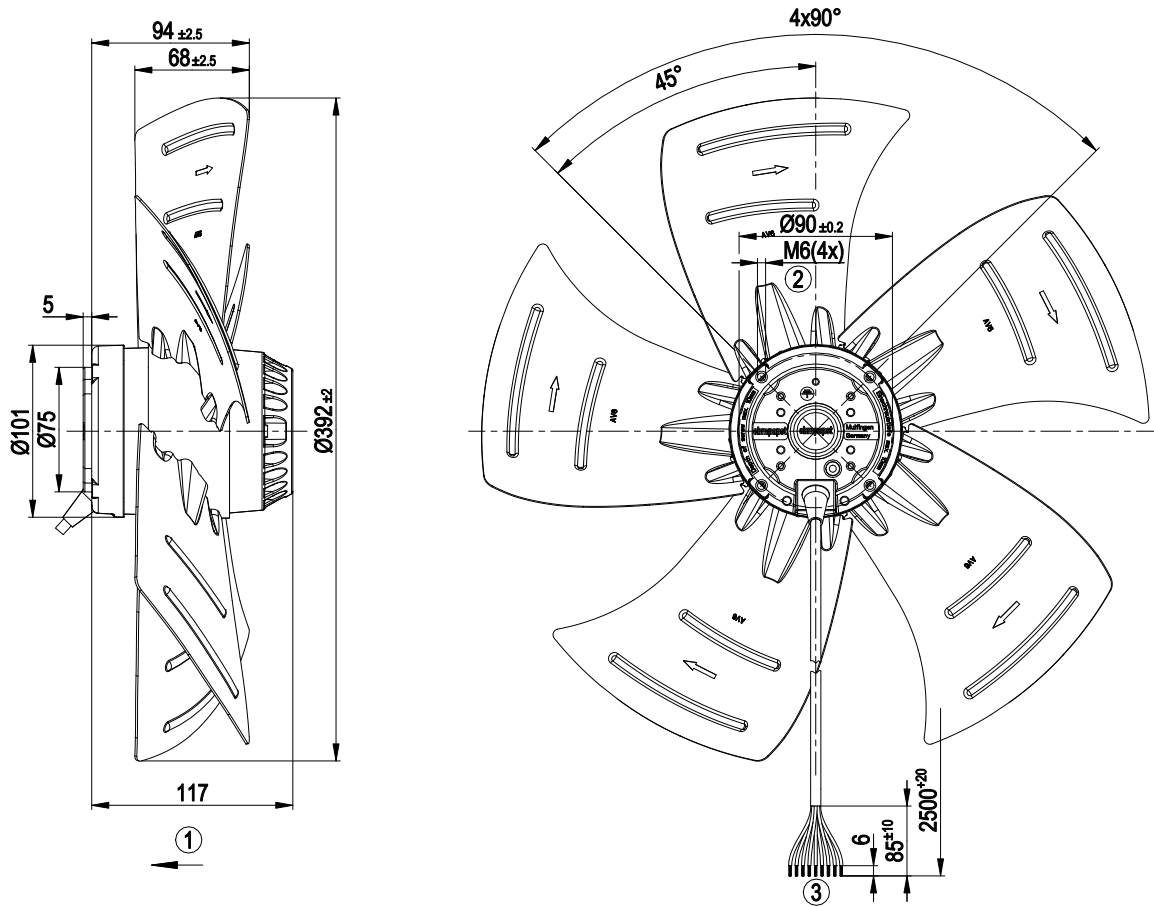

1	Direction of air flow "V"
2	Cable Dipotherm 0.5 mm ² , 9x crimped splices
3	Max. clearance for screw 10 mm



Connection diagram

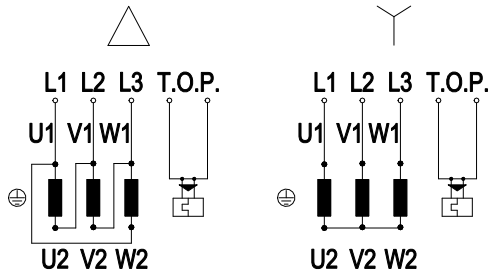

Note: Change of rotation direction by reversing two phases

Δ	Delta connection	Y	Star connection	L1	black
L2	blue	L3	brown	U1	black
V1	blue	W1	brown	U2	green
V2	white	W2	yellow	TOP	gray

Curves: Air performance 50 Hz

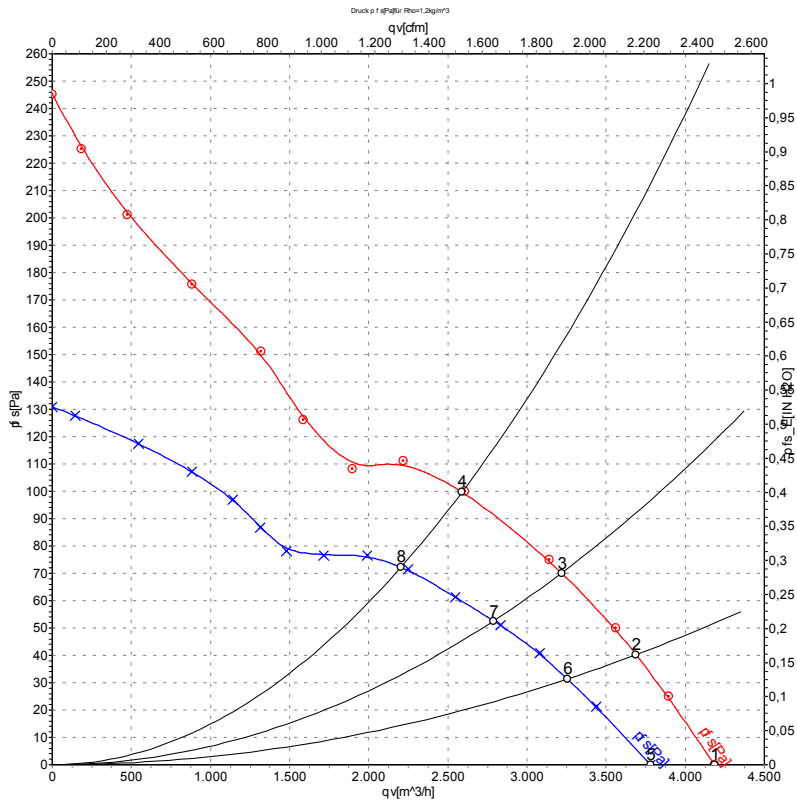

Measurement: LU-43060-1
Measurement: LU-51669-1

Air performance measured according to ISO 5801 installation category A. For detailed information on the measurement setup, contact ebm-papst. Intake sound level: Sound power level according to ISO 13347 / sound pressure level measured at 1 m distance from fan axis. The values given are valid under the specified measuring conditions and may vary due to conditions of installation. For deviations from the standard configuration, the parameters have to be checked on the installed unit.

Measured values

	Wired	U	f	n	P_e	I	qv	p_{fs}	qv	p_{fs}
		V	Hz	min^{-1}	W	A	m^3/h	Pa	CFM	inH2O
1	Δ	400	50	1440	170	0.53	4185	0	2465	0.00
2	Δ	400	50	1425	192	0.51	3690	40	2170	0.16
3	Δ	400	50	1415	211	0.51	3220	70	1895	0.28
4	Δ	400	50	1400	229	0.53	2590	100	1525	0.40
5	Y	400	50	1300	115	0.21	3780	0	2225	0.00
6	Y	400	50	1255	131	0.23	3255	31	1915	0.12
7	Y	400	50	1220	145	0.25	2790	53	1640	0.21
8	Y	400	50	1180	156	0.27	2205	72	1295	0.29

Wired = Wiring · U = Power supply · f = Frequency · n = Speed (rpm) · P_e = Power consumption · I = Current draw · qv = Air flow · p_{fs} = Pressure increase



Curves: Air performance 60 Hz

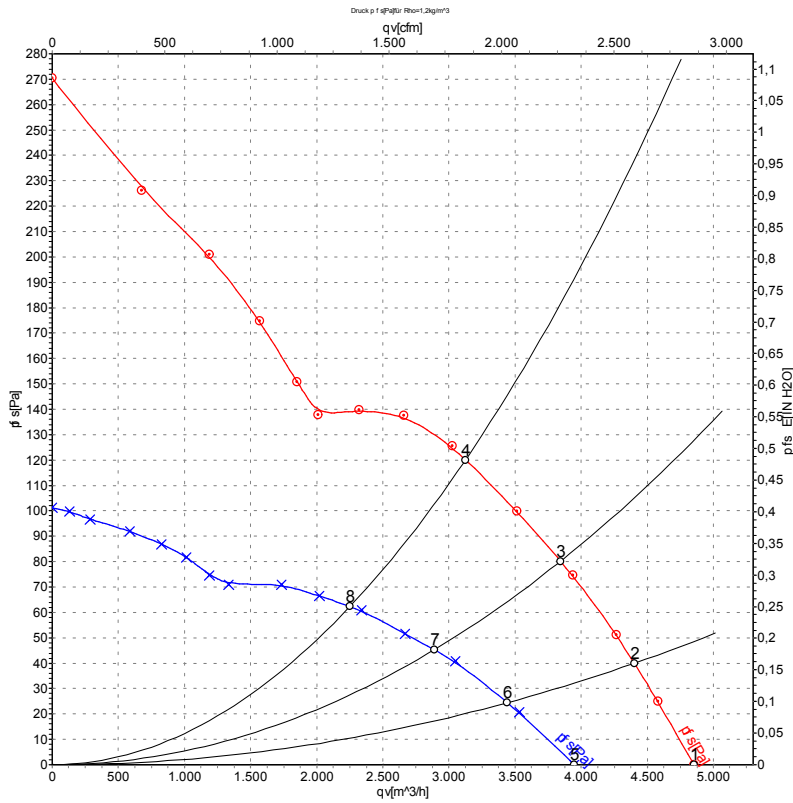

Measurement: LU-43061-1
Measurement: LU-51672-1

Air performance measured according to ISO 5801 installation category A. For detailed information on the measurement setup, contact ebm-papst. Intake sound level: Sound power level according to ISO 13347 / sound pressure level measured at 1 m distance from fan axis. The values given are valid under the specified measuring conditions and may vary due to conditions of installation. For deviations from the standard configuration, the parameters have to be checked on the installed unit.

Measured values

	Wired	U	f	n	P _e	I	qv	p _{fs}	qv	p _{fs}
		V	Hz	min ⁻¹	W	A	m ³ /h	Pa	CFM	inH ₂ O
1	Δ	400	60	1670	210	0.44	4850	0	2855	0.00
2	Δ	400	60	1650	245	0.47	4400	40	2590	0.16
3	Δ	400	60	1625	279	0.51	3845	80	2260	0.32
4	Δ	400	60	1600	311	0.55	3125	120	1840	0.48
5	Y	400	60	1360	160	0.27	3950	0	2325	0.00
6	Y	400	60	1280	173	0.29	3440	25	2025	0.10
7	Y	400	60	1205	185	0.32	2890	45	1700	0.18
8	Y	400	60	1135	195	0.33	2250	62	1325	0.25

Wired = Wiring · U = Power supply · f = Frequency · n = Speed (rpm) · P_e = Power consumption · I = Current draw · qv = Air flow · p_{fs} = Pressure increase

