



A4D400-AP12-28 ebmpapst Datasheet

sales@fansco.com

www.fansco.com

Limited partnership · Headquarters Mulfingen

Amtsgericht (court of registration) Stuttgart · HRA 590344

General partner Elektrobau Mulfingen GmbH · Headquarters Mulfingen

Amtsgericht (court of registration) Stuttgart · HRB 590142

Nominal data

Type	A4D400-AP12-28				
Motor	M4D074-EI				
Phase		3~	3~	3~	3~
Nominal voltage	VAC	230	230	400	400
Wiring		Δ	Δ	Y	Y
Frequency	Hz	50	60	50	60
Method of obtaining data		fa	fa	fa	fa
Valid for approval/standard		CE	CE	CE	CE
Speed (rpm)	min ⁻¹	1450	1690	1450	1690
Power consumption	W	135	185	135	185
Current draw	A	0.76	0.68	0.44	0.39
Max. back pressure	Pa	105	120	105	120
Max. back pressure	in. wg	0.42	0.48	0.42	0.48
Min. ambient temperature	°C	-25	-25	-25	-25
Max. ambient temperature	°C	60	60	60	60
Starting current	A	3.0	3.0	1.7	1.7

ml = Max. load · me = Max. efficiency · fa = Free air · cs = Customer specification · ce = Customer equipment
Subject to change

Data according to Commission Regulation (EU) 327/2011

		Actual	Req. 2015		
01 Overall efficiency η_{es}	%	33.2	29.1	09 Power consumption P_e	kW 0.19
02 Measurement category		A		09 Air flow q_v	m ³ /h 2595
03 Efficiency category		Static		09 Pressure increase p_{fs}	Pa 91
04 Efficiency grade N		44.1	40	10 Speed (rpm) n	min ⁻¹ 1415
05 Variable speed drive		No		11 Specific ratio*	1.00

Data obtained at optimum efficiency level.
The ErP data is determined using a motor-impeller combination in a standardized measurement setup.

* Specific ratio = $1 + p_{fs} / 100\,000\text{ Pa}$

LU-27622



Technical description

Weight	4.1 kg
Size	400 mm
Motor size	74
Rotor surface	Painted black
Blade material	Sheet steel, painted black
Number of blades	5
Airflow direction	V
Direction of rotation	Counterclockwise, viewed toward rotor
Degree of protection	IP44; installation- and position-dependent as per EN 60034-5
Insulation class	"F"
Moisture (F) / Environmental (H) protection class	H1
Max. permitted ambient temp. for motor (transport/storage)	+ 80 °C
Min. permitted ambient temp. for motor (transport/storage)	- 40 °C
Installation position	Shaft horizontal or rotor on bottom; rotor on top on request
Condensation drainage holes	On rotor side
Mode	S1
Motor mounting	Ball bearing
Touch current according to IEC 60990 (measuring circuit Fig. 4, TN system)	< 0.75 mA
With cable	Variable
Protection class	I (with customer connection of protective earth)
Conformity with standards	EN 60335-1; CE
Approval	UL 1004-1; CSA C22.2 No. 100

AC axial fan

sickle-shaped blades (S series), single-intake

Product drawing

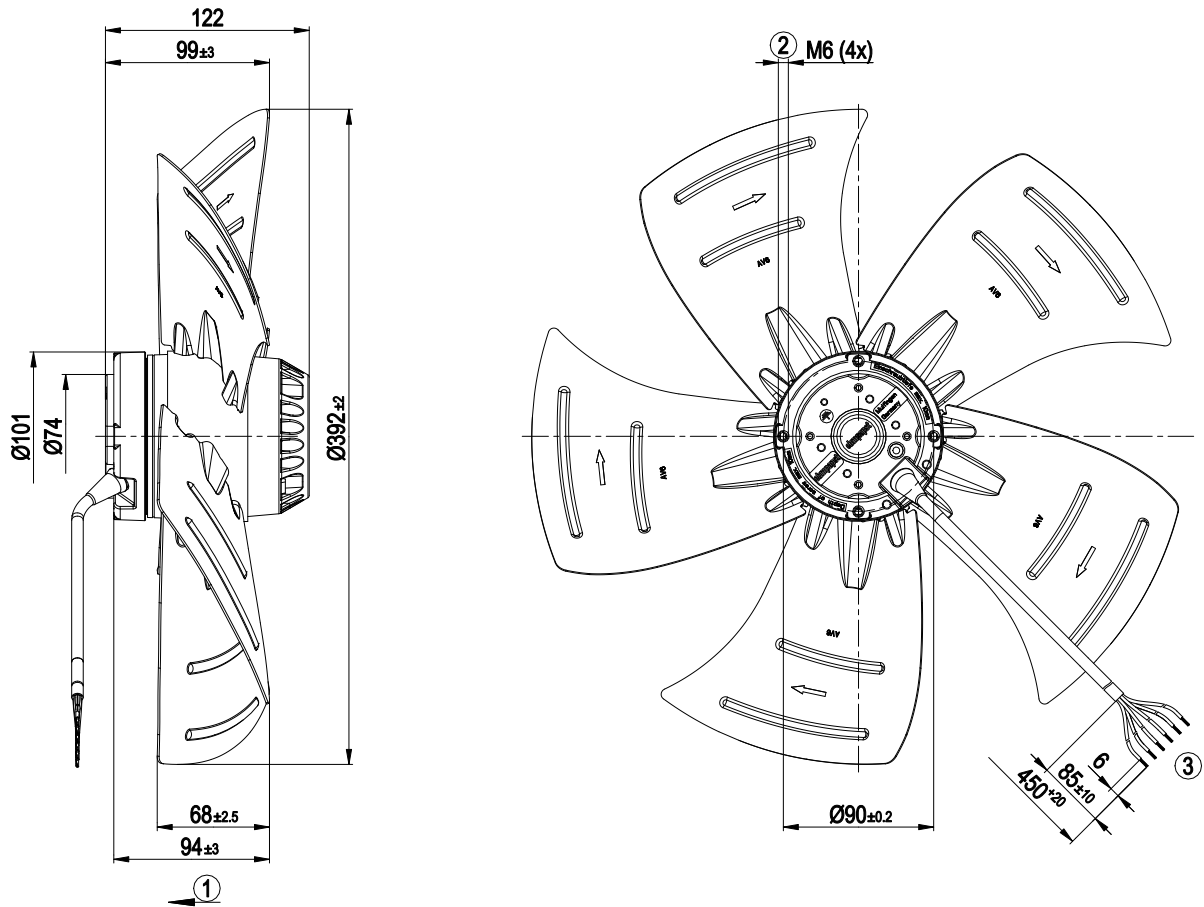

1	Airflow direction "V"
2	Max. clearance for screw 10 mm
3	Cable PFA AWG20 (green/yellow AWG18) 6x splice



Connection diagram

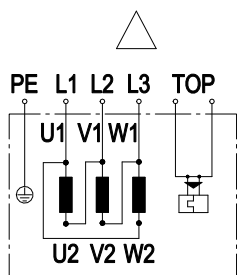

Note: Change of rotation direction by reversing two phases

Δ	Delta connection	L1	= U1 = black	L2	= V1 = blue
L3	= W1 = brown	TOP	2x gray	PE	green/yellow

Curves: Air performance 50 Hz

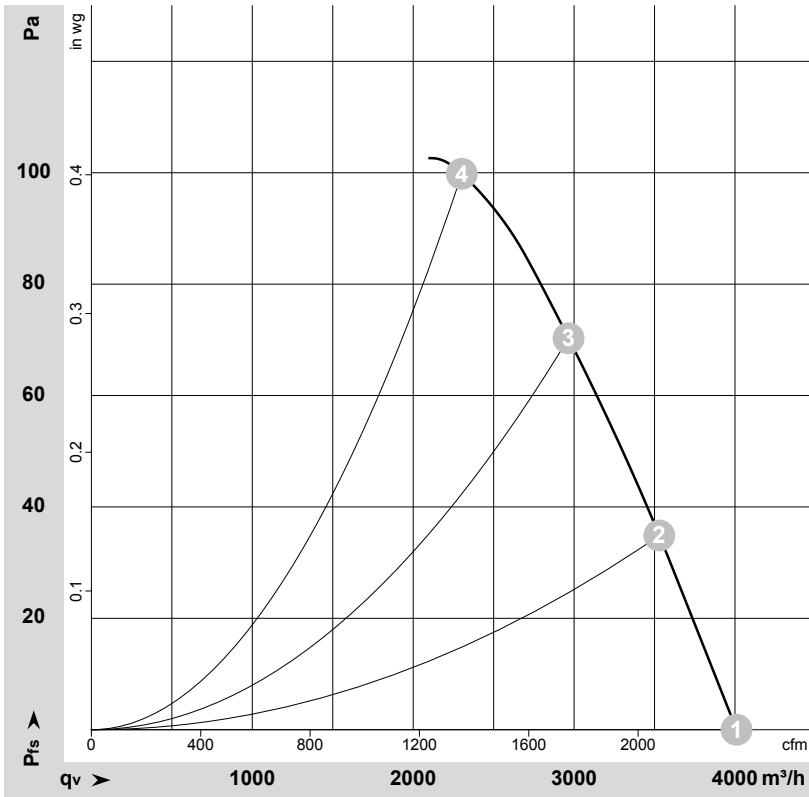

$\rho = 1.15 \text{ kg/m}^3 \pm 2 \%$

Measurement: LU-27622-1

Air performance measured according to ISO 5801 installation category A. For detailed information on the measurement setup, contact ebmpapst. Intake sound level: Sound power level according to ISO 13347 / sound pressure level measured at 1 m distance from fan axis. The values given are valid under the specified measuring conditions and may vary due to conditions of installation. For deviations from the standard configuration, the parameters have to be checked on the installed unit.

Measured values

	Wired	U	f	n	P _e	I	q _v	p _{fs}	q _v	p _{fs}
		V	Hz	min ⁻¹	W	A	m ³ /h	Pa	cfm	in. wg
1	Y	400	50	1450	135	0.44	4010	0	2360	0.00
2	Y	400	50	1435	161	0.47	3530	35	2080	0.14
3	Y	400	50	1420	183	0.49	2965	70	1745	0.28
4	Y	400	50	1410	204	0.50	2300	100	1355	0.40

Wired = Wiring · U = Power supply · f = Frequency · n = Speed (rpm) · P_e = Power consumption · I = Current draw · q_v = Air flow · p_{fs} = Pressure increase



Curves: Air performance 60 Hz

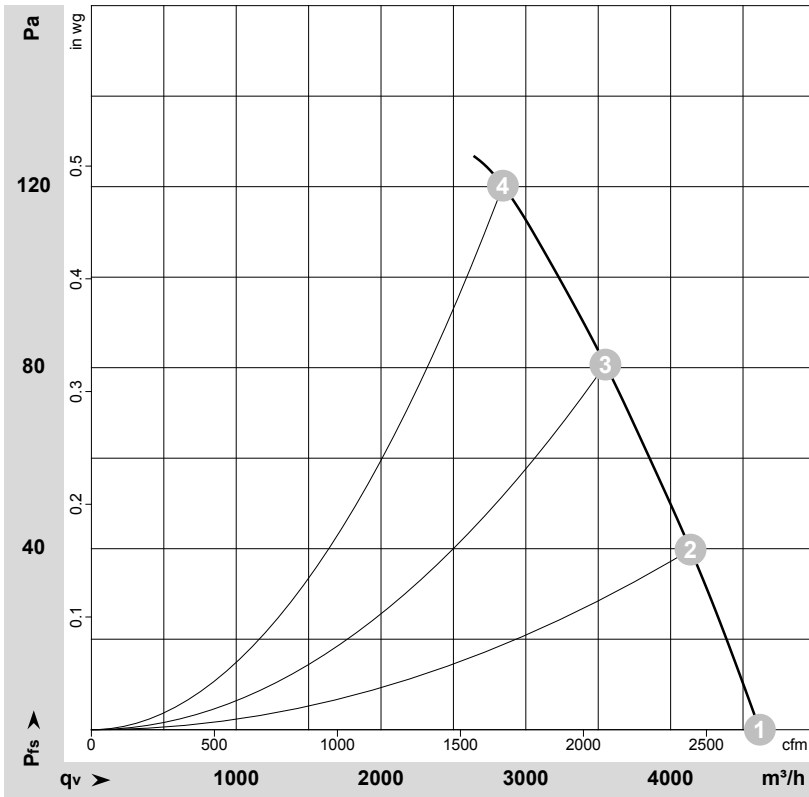

$\rho = 1.15 \text{ kg/m}^3 \pm 2 \%$

Measurement: LU-27623-1

Air performance measured according to ISO 5801 installation category A. For detailed information on the measurement setup, contact ebmpapst. Intake sound level: Sound power level according to ISO 13347 / sound pressure level measured at 1 m distance from fan axis. The values given are valid under the specified measuring conditions and may vary due to conditions of installation. For deviations from the standard configuration, the parameters have to be checked on the installed unit.

Measured values

	Wired	U	f	n	P _e	I	q _v	p _{fs}	q _v	p _{fs}
		V	Hz	min ⁻¹	W	A	m ³ /h	Pa	cfm	in. wg
1	Y	400	60	1690	185	0.39	4615	0	2715	0.00
2	Y	400	60	1660	223	0.45	4140	40	2435	0.16
3	Y	400	60	1635	257	0.49	3550	80	2090	0.32
4	Y	400	60	1605	292	0.54	2840	120	1675	0.48

Wired = Wiring · U = Power supply · f = Frequency · n = Speed (rpm) · P_e = Power consumption · I = Current draw · q_v = Air flow · p_{fs} = Pressure increase

