

A4D400-AP12-27 ebmpapst Datasheet

sales@fansco.com

www.fansco.com

Limited partnership · Headquarters Mulfingen

Amtsgericht (court of registration) Stuttgart · HRA 590344

General partner Elektrobau Mulfingen GmbH · Headquarters Mulfingen

Amtsgericht (court of registration) Stuttgart · HRB 590142

## Nominal data

Type	A4D400-AP12-27		
Motor	M4D074-EI		
Phase		3~	3~
Nominal voltage	VAC	400	400
Wiring		Y	Y
Frequency	Hz	50	60
Method of obtaining data		fa	fa
Valid for approval/standard		CE	CE
Speed (rpm)	min <sup>-1</sup>	1450	1690
Power consumption	W	135	185
Current draw	A	0.44	0.39
Max. back pressure	Pa	105	120
Max. back pressure	in. wg	0.42	0.48
Min. ambient temperature	°C	-25	-25
Max. ambient temperature	°C	40	40
Starting current	A	1.7	1.7

ml = Max. load · me = Max. efficiency · fa = Free air · cs = Customer specification · ce = Customer equipment  
Subject to change

## Data according to Commission Regulation (EU) 327/2011

		Actual	Req. 2015			
01 Overall efficiency $\eta_{es}$	%	32.7	29.1	09 Power consumption $P_e$	kW	0.19
02 Measurement category		A		09 Air flow $q_v$	m <sup>3</sup> /h	2595
03 Efficiency category		Static		09 Pressure increase $p_{fs}$	Pa	91
04 Efficiency grade N		43.6	40	10 Speed (rpm) n	min <sup>-1</sup>	1415
05 Variable speed drive		No		11 Specific ratio*		1.00

Data obtained at optimum efficiency level.  
The ErP data is determined using a motor-impeller combination in a standardized measurement setup.

\* Specific ratio =  $1 + p_s / 100\,000\text{ Pa}$ 

LU-27622



### Technical description

Weight	4.5 kg
Size	400 mm
Motor size	74
Rotor surface	Painted black
Blade material	Sheet steel, painted black
Number of blades	5
Airflow direction	A
Direction of rotation	Clockwise, viewed toward rotor
Degree of protection	IP44; installation- and position-dependent
Insulation class	"B"
Moisture (F) / Environmental (H) protection class	H2; F3-1
Max. permitted ambient temp. for motor (transport/storage)	+ 80 °C
Min. permitted ambient temp. for motor (transport/storage)	- 40 °C
Installation position	Any
Condensation drainage holes	None
Mode	S1
Motor bearing	Ball bearing
Touch current according to IEC 60990 (measuring circuit Fig. 4, TN system)	< 0.75 mA
With cable	Variable
Protection class	I (with customer connection of protective earth)
Conformity with standards	EN 60335-1; CE

# AC axial fan

sickle-shaped blades (S series), single-intake

## Product drawing

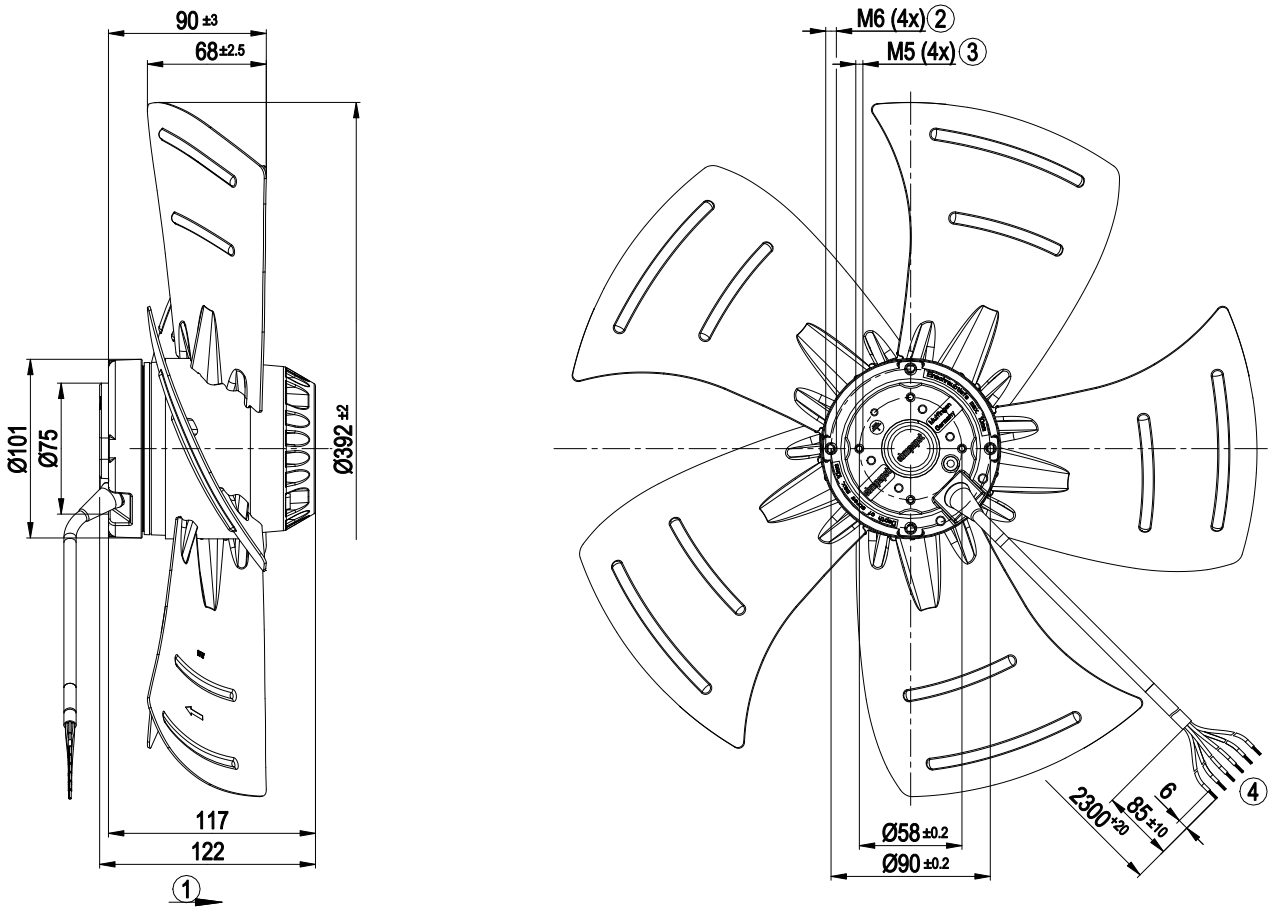

1	Direction of air flow "A"
2	Max. clearance for screw 10 mm
3	Max. clearance for screw 5 mm
4	Cable silicone 6G 0.5 mm <sup>2</sup>
	6x splice



## Connection diagram

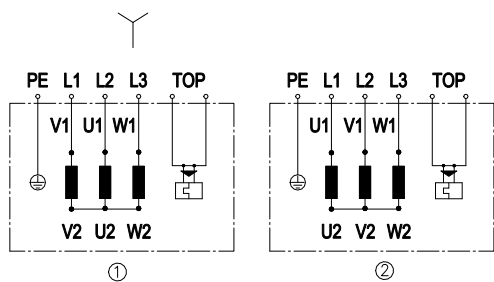

Change of rotation direction by reversing two phases

	Three-phase motor
Y	Star connection
1	Counterclockwise operation
L1	= V1 = blue
L2	= U1 = black
L3	= W1 = brown
2	Clockwise operation
L1	= U1 = black
L2	= V1 = blue
L3	= W1 = brown
PE	green/yellow
TOP	2x gray

## Curves: Air performance 50 Hz

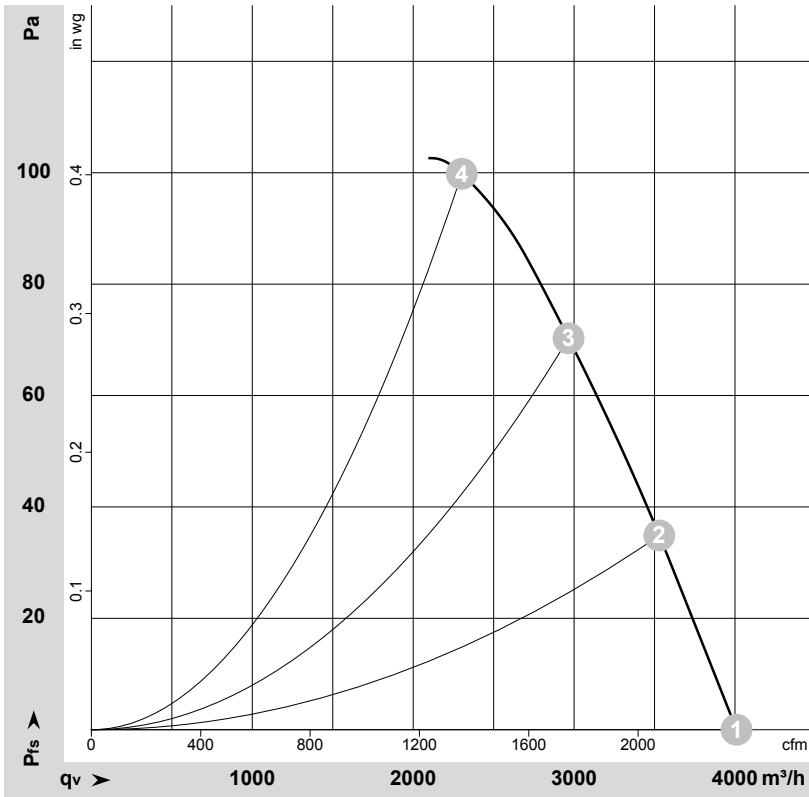

$\rho = 1.15 \text{ kg/m}^3 \pm 2 \%$

Measurement: LU-27622-1

Air performance measured according to ISO 5801 installation category A. For detailed information on the measurement setup, contact ebmpapst. Intake sound level: Sound power level according to ISO 13347 / sound pressure level measured at 1 m distance from fan axis. The values given are valid under the specified measuring conditions and may vary due to conditions of installation. For deviations from the standard configuration, the parameters have to be checked on the installed unit.

## Measured values

	Wired	U	f	n	P <sub>e</sub>	I	q <sub>v</sub>	P <sub>fs</sub>	q <sub>v</sub>	P <sub>fs</sub>
		V	Hz	min <sup>-1</sup>	W	A	m <sup>3</sup> /h	Pa	cfm	in. wg
1	Y	400	50	1450	135	0.44	4010	0	2360	0.00
2	Y	400	50	1435	161	0.47	3530	35	2080	0.14
3	Y	400	50	1420	183	0.49	2965	70	1745	0.28
4	Y	400	50	1410	204	0.50	2300	100	1355	0.40

Wired = Wiring · U = Voltage · f = Frequency · n = Speed (rpm) · P<sub>e</sub> = Power consumption · I = Current draw · q<sub>v</sub> = Air flow · P<sub>fs</sub> = Pressure increase



## Curves: Air performance 60 Hz

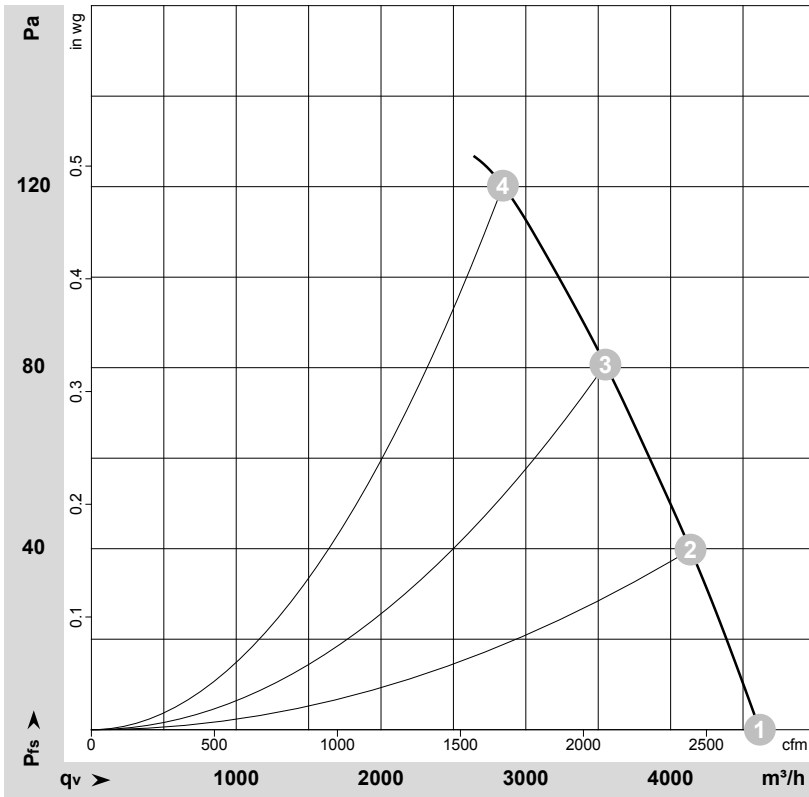

$\rho = 1.15 \text{ kg/m}^3 \pm 2 \%$

Measurement: LU-27623-1

Air performance measured according to ISO 5801 installation category A. For detailed information on the measurement setup, contact ebmpapst. Intake sound level: Sound power level according to ISO 13347 / sound pressure level measured at 1 m distance from fan axis. The values given are valid under the specified measuring conditions and may vary due to conditions of installation. For deviations from the standard configuration, the parameters have to be checked on the installed unit.

## Measured values

	Wired	U	f	n	P <sub>e</sub>	I	q <sub>v</sub>	P <sub>fs</sub>	q <sub>v</sub>	P <sub>fs</sub>
		V	Hz	min <sup>-1</sup>	W	A	m <sup>3</sup> /h	Pa	cfm	in. wg
1	Y	400	60	1690	185	0.39	4615	0	2715	0.00
2	Y	400	60	1660	223	0.45	4140	40	2435	0.16
3	Y	400	60	1635	257	0.49	3550	80	2090	0.32
4	Y	400	60	1605	292	0.54	2840	120	1675	0.48

Wired = Wiring · U = Voltage · f = Frequency · n = Speed (rpm) · P<sub>e</sub> = Power consumption · I = Current draw · q<sub>v</sub> = Air flow · P<sub>fs</sub> = Pressure increase

