



A4D400-AP12-02 ebmpapst Datasheet FansCo

sales@fansco.com

www.fansco.com

Nominal data

Type	A4D400-AP12-02				
Motor	M4D074-EI				
Phase		3~	3~	3~	3~
Nominal voltage	VAC	230	230	400	400
Connection		Δ	Δ	Y	Y
Frequency	Hz	50	60	50	60
Type of data definition		fa	fa	fa	fa
Valid for approval / standard		CE	CE	CE	CE
Speed	min ⁻¹	1450	1690	1450	1690
Power input	W	135	185	135	185
Current draw	A	0.76	0.68	0.44	0.39
Max. back pressure	Pa	150	120	150	120
Min. ambient temperature	°C	-25	-25	-25	-25
Max. ambient temperature	°C	40	40	40	40
Starting current	A	3.0	3.0	1.7	1.7

ml = Max. load · me = Max. efficiency · fa = Running at free air · cs = Customer specs · cu = Customer unit
Subject to alterations

Data according to ErP directive

Installation category	A
Efficiency category	Static
Variable speed drive	No
Specific ratio*	1.00

* Specific ratio = $1 + p_{fs} / 100\,000\text{ Pa}$

		Actual	Request 2013	Request 2015
Overall efficiency η_{es}	%	32.7	25.1	29.1
Efficiency grade N		43.6	36	40
Power input P_e	kW	0.19		
Air flow q_v	m ³ /h	2595		
Pressure increase p_{fs}	Pa	91		
Speed n	min ⁻¹	1415		

Data definition with optimum efficiency. LU-27622
The ErP data is determined using a motor-impeller combination in a standardised measurement configuration.



AC axial fan

sickled blades (S series)

Technical features

Mass	4.2 kg
Size	400 mm
Surface of rotor	Coated in black
Material of blades	Sheet steel, coated in black
Number of blades	5
Direction of air flow	"A"
Direction of rotation	Clockwise, seen on rotor
Type of protection	IP 44; Depending on installation and position as per EN 60034-5
Insulation class	"B"
Humidity class	F1-2
Max. permissible ambient motor temp. (transp./ storage)	+ 80 °C
Min. permissible ambient motor temp. (transp./storage)	- 40 °C
Mounting position	Shaft horizontal or rotor on bottom; rotor on top on request
Condensate discharge holes	Rotor-side
Operation mode	S1
Motor bearing	Ball bearing
Touch current acc. IEC 60990 (measuring network Fig. 4, TN system)	< 0.75 mA
Cable exit	Variable
Protection class	I (if protective earth is connected by customer)
Product conforming to standard	EN 60335-1; CE
Approval	CCC; EAC



Product drawing

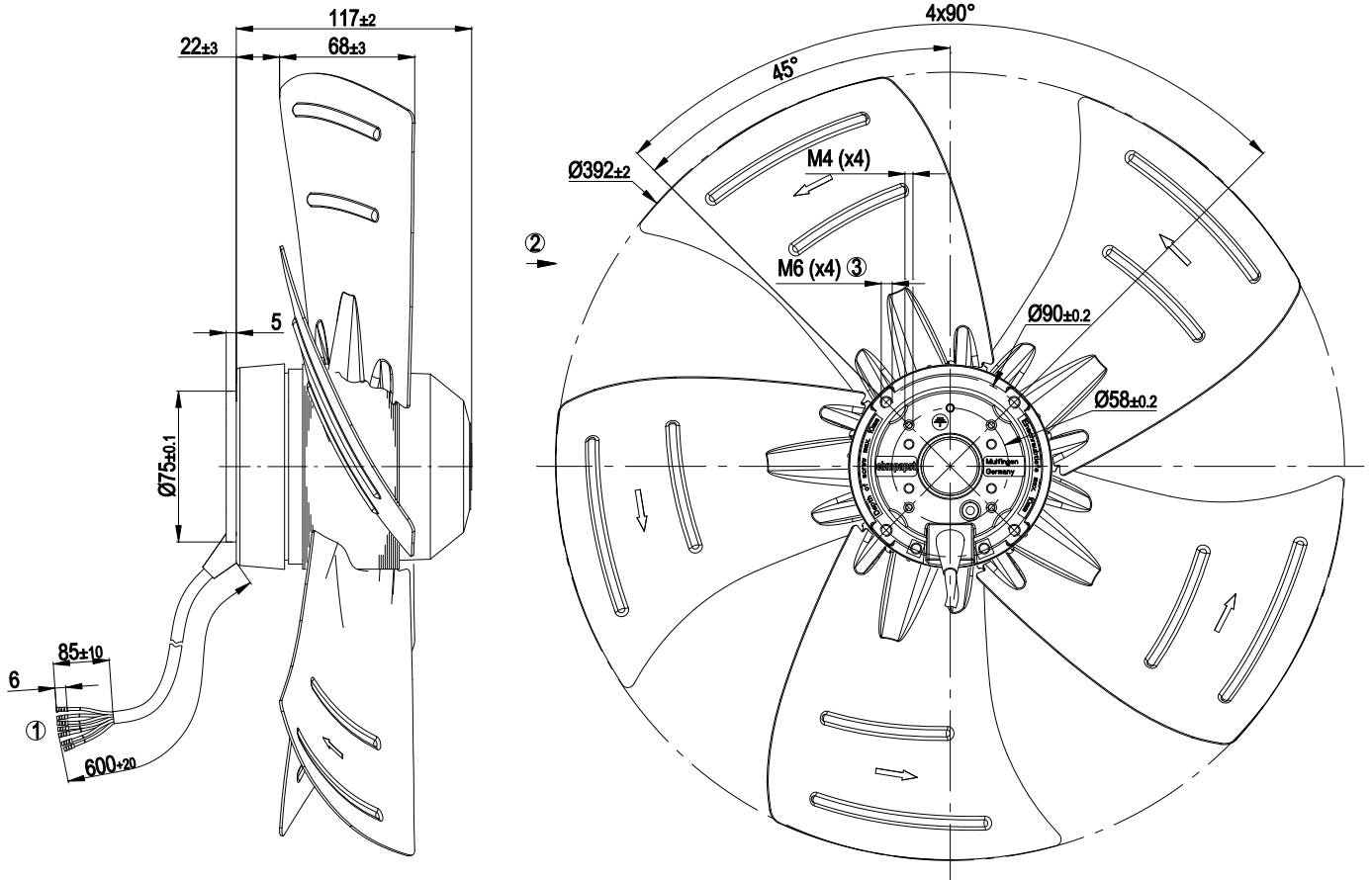

1	Connection line PVC 7G 0.5mm ² , 7x brass lead tips crimped
2	Direction of air flow "A"
3	Depth of screw max. 10 mm



Connection screen

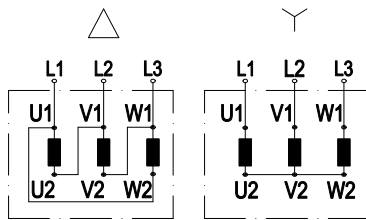

Change direction of rotation by reversing two phases

	Three-phase motor	Δ	Delta connection	Y	Star connection
L1	= U1 = black	L2	= V1 = blue	L3	= W1 = brown
U2	green	V2	white	W2	yellow

Charts: Air flow 50 Hz

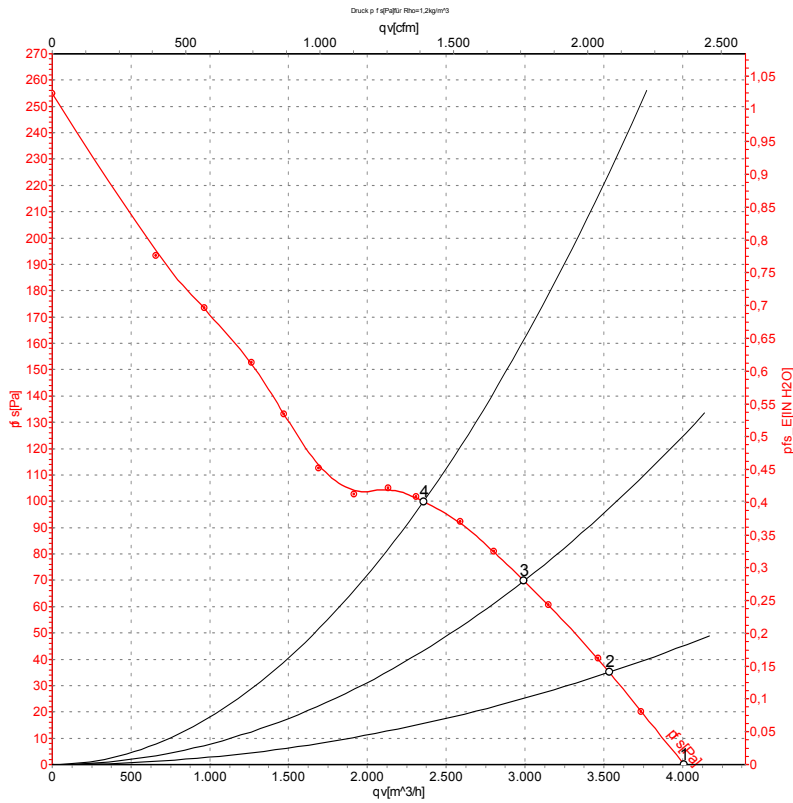

Air performance measured as per ISO 5801 Installation category A. For detailed information on the measuring set-up, please contact ebmpapst. Suction-side noise levels: LwA measured as per ISO 13347 / LpA measured with 1m distance to fan axis. The values given are valid under the measuring conditions mentioned above and may vary according to the actual installation situation. With any deviation from the standard set-up, the specific values have to be checked and reviewed with the unit installed.

Measured values

	Conn.	U	f	n	Pe	I	LpA _{in}	LwA _{in}	qv	p _{fs}
		V	Hz	min ⁻¹	W	A	dB(A)	dB(A)	m ³ /h	Pa
1	Y	400	50	1450	135	0.44	65	74	4000	0
2	Y	400	50	1435	161	0.47	65	73	3535	35
3	Y	400	50	1420	182	0.49	65	72	2995	70
4	Y	400	50	1410	203	0.50	67	74	2355	100

Conn. = Connection · U = Supply voltage · f = Frequency · n = Speed · P_e = Power input · I = Current draw · LpA_{in} = Sound pressure level inlet side · LwA_{in} = Sound power level inlet side
 qv = Air flow · p_{fs} = Pressure increase



Charts: Air flow 60 Hz

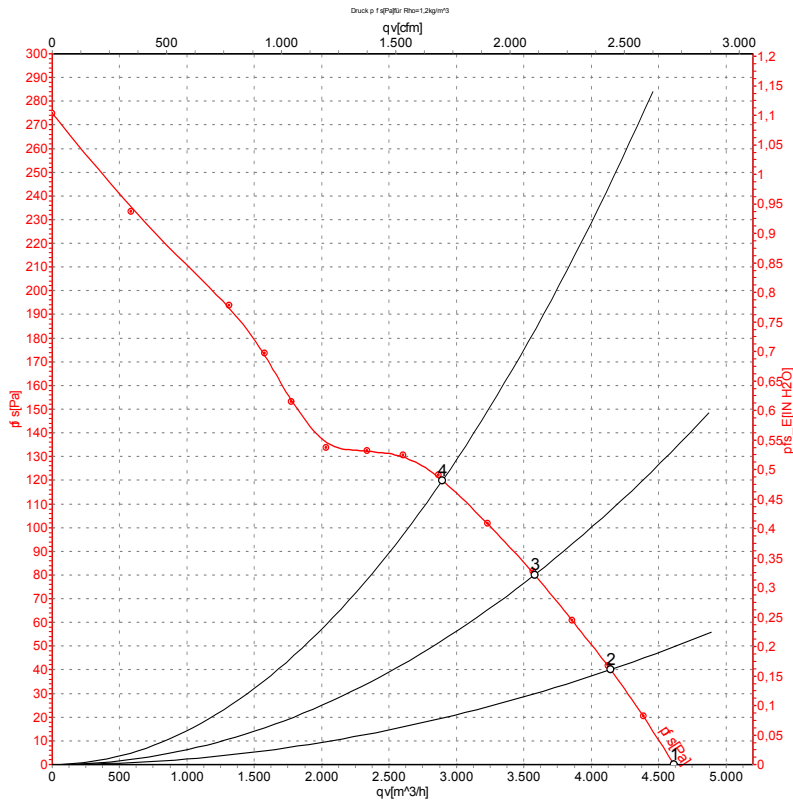

Air performance measured as per ISO 5801 Installation category A. For detailed information on the measuring set-up, please contact ebmpapst. Suction-side noise levels: LwA measured as per ISO 13347 / LpA measured with 1m distance to fan axis. The values given are valid under the measuring conditions mentioned above and may vary according to the actual installation situation. With any deviation from the standard set-up, the specific values have to be checked and reviewed with the unit installed.

Measured values

	Conn.	U	f	n	P _e	I	LpA _{in}	LwA _{in}	qv	p _{fs}
		V	Hz	min ⁻¹	W	A	dB(A)	dB(A)	m ³ /h	Pa
1	Y	400	60	1690	185	0.39	69	76	4615	0
2	Y	400	60	1660	223	0.45	70	76	4145	40
3	Y	400	60	1635	256	0.49	69	76	3580	80
4	Y	400	60	1605	290	0.54	70	76	2895	120

Conn. = Connection · U = Supply voltage · f = Frequency · n = Speed · P_e = Power input · I = Current draw · LpA_{in} = Sound pressure level inlet side · LwA_{in} = Sound power level inlet side
 qv = Air flow · p_{fs} = Pressure increase

