

A4D350-AP08-01 ebmpapst Datasheet

sales@fansco.com

www.fansco.com

Nominal data

Type	A4D350-AP08-01				
Motor	M4D074-DF				
Phase		3~	3~	3~	3~
Nominal voltage	VAC	230	230	400	400
Wiring		Δ	Δ	Y	Y
Frequency	Hz	50	60	50	60
Method of obtaining data		fa	fa	fa	fa
Valid for approval/standard		CE	CE	CE	CE
Speed (rpm)	min ⁻¹	1410	1600	1410	1600
Power consumption	W	130	180	130	180
Current draw	A	0.61	0.59	0.35	0.34
Max. back pressure	Pa	90	90	90	90
Max. back pressure	inH ₂ O	0.36	0.36	0.36	0.36
Min. ambient temperature	°C	-25	-25	-25	-25
Max. ambient temperature	°C	50	40	50	40

ml = Max. load · me = Max. efficiency · fa = Free air · cs = Customer specification · ce = Customer equipment
Subject to change

Data according to ErP Directive

		Actual	Req. 2015			
01 Overall efficiency η_{es}	%	30.7	28.5	09 Power consumption P_e	kW	0.15
02 Measurement category		A		09 Air flow q_v	m ³ /h	2110
03 Efficiency category		Static		09 Pressure increase p_{fs}	Pa	80
04 Efficiency grade N		42.2	40	10 Speed (rpm) n	min ⁻¹	1385
05 Variable speed drive		No		11 Specific ratio*		1.00

Data obtained at optimum efficiency level.
The ErP data is determined using a motor-impeller combination in a standardized measurement setup.

* Specific ratio = $1 + p_g / 100\,000\text{ Pa}$

LU-28615



Technical description

Weight	3.6 kg
Fan size	350 mm
Rotor surface	Painted black
Blade material	Sheet steel, painted black
Number of blades	5
Airflow direction	"V"
Direction of rotation	Counterclockwise, viewed toward rotor
Degree of protection	IP44; installation- and position-dependent as per EN 60034-5
Insulation class	"B"
Moisture (F) / Environmental (H) protection class	H0+
Max. permitted ambient temp. for motor (transport/storage)	+ 80 °C
Min. permitted ambient temp. for motor (transport/storage)	- 40 °C
Installation position	Shaft horizontal or rotor on bottom; rotor on top on request
Condensation drainage holes	On rotor side
Mode	S1
Motor bearing	Ball bearing
Touch current according to IEC 60990 (measuring circuit Fig. 4, TN system)	< 0.75 mA
With cable	Variable
Protection class	I (with customer connection of protective earth)
Conformity with standards	EN 60335-1

Product drawing

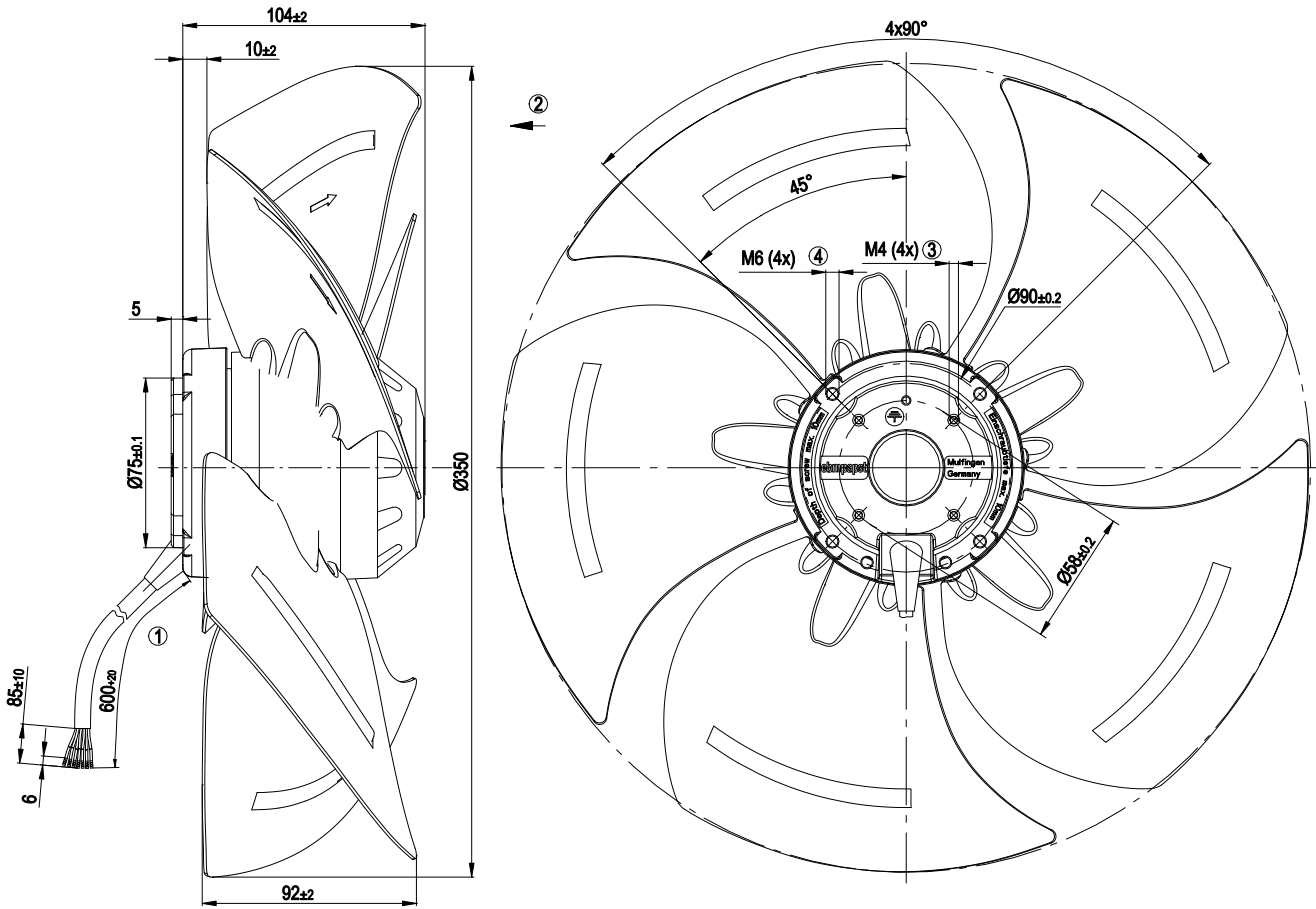

1	Cable PVC 7G 0.5mm ² , 7x crimped splices
2	Direction of air flow "V"
3	Max. clearance for screw 5 mm
4	Max. clearance for screw 10 mm



Connection diagram

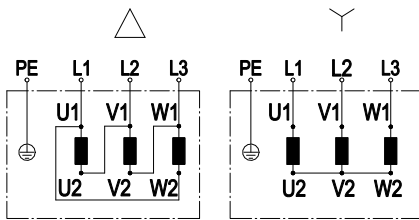

Change of rotation direction by reversing two phases

	Three-phase motor	Δ	Delta connection	Y	Star connection
L1	= U1 = black	L2	= V1 = blue	L3	= W1 = brown
U2	green	V2	white	W2	yellow
PE	green/yellow				

Curves: Air performance 50 Hz

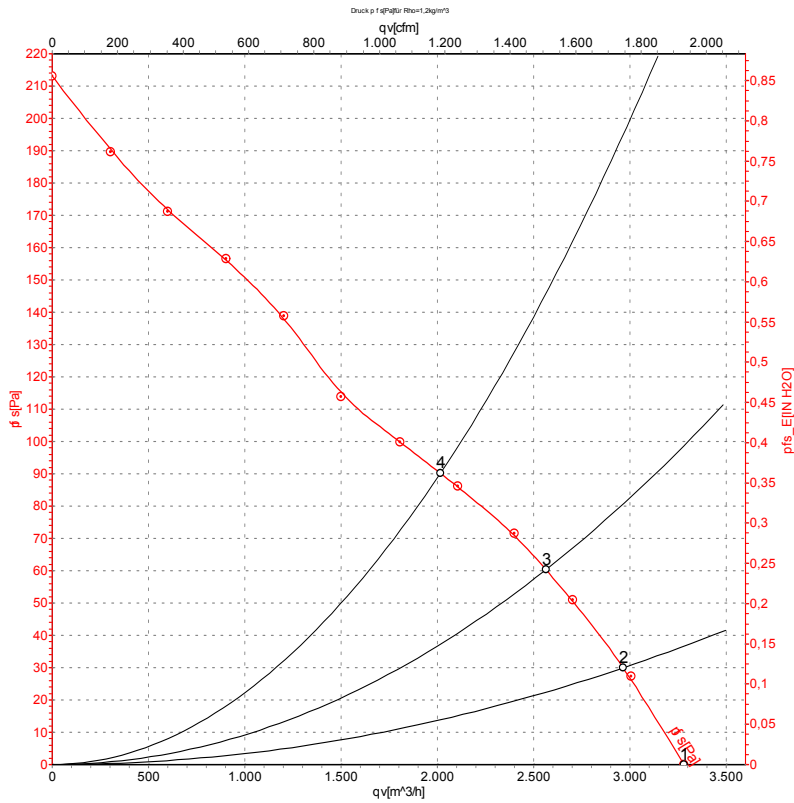

Measurement: LU-122615-1

Air performance measured according to ISO 5801 installation category A. For detailed information on the measurement setup, contact ebm-papst. Intake sound level: Sound power level according to ISO 13347 / sound pressure level measured at 1 m distance from fan axis. The values given are valid under the specified measuring conditions and may vary due to conditions of installation. For deviations from the standard configuration, the parameters have to be checked on the installed unit.

Measured values

	Wired	U	f	n	P _e	I	qv	p _{fs}	qv	p _{fs}
		V	Hz	min ⁻¹	W	A	m ³ /h	Pa	CFM	inH2O
1	Y	400	50	1410	130	0.35	3280	0	1930	0.00
2	Y	400	50	1395	145	0.35	2965	30	1745	0.12
3	Y	400	50	1380	158	0.36	2565	60	1510	0.24
4	Y	400	50	1355	179	0.38	2015	90	1185	0.36

Wired = Wiring · U = Power supply · f = Frequency · n = Speed (rpm) · P_e = Power consumption · I = Current draw · qv = Air flow · p_{fs} = Pressure increase



Curves: Air performance 60 Hz

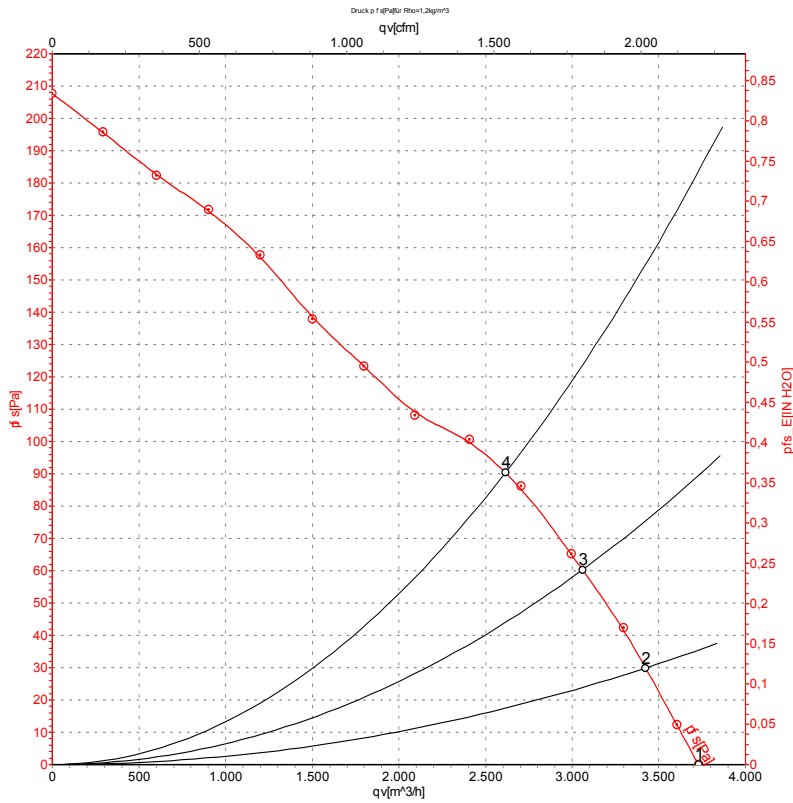

Measurement: LU-122616-1

Air performance measured according to ISO 5801 installation category A. For detailed information on the measurement setup, contact ebm-papst. Intake sound level: Sound power level according to ISO 13347 / sound pressure level measured at 1 m distance from fan axis. The values given are valid under the specified measuring conditions and may vary due to conditions of installation. For deviations from the standard configuration, the parameters have to be checked on the installed unit.

Measured values

	Wired	U	f	n	P _e	I	qv	p _{fs}	qv	p _{fs}
		V	Hz	min ⁻¹	W	A	m ³ /h	Pa	CFM	inH ₂ O
1	Y	400	60	1600	180	0.34	3730	0	2195	0.00
2	Y	400	60	1585	196	0.35	3425	30	2015	0.12
3	Y	400	60	1555	214	0.37	3060	60	1800	0.24
4	Y	400	60	1525	232	0.40	2615	90	1540	0.36

Wired = Wiring · U = Power supply · f = Frequency · n = Speed (rpm) · P_e = Power consumption · I = Current draw · qv = Air flow · p_{fs} = Pressure increase

