

A4D350-AN08-24 ebmpapst Datasheet

sales@fansco.com

www.fansco.com

Limited partnership · Headquarters Muldingen
County court Stuttgart · HRA 590344

General partner Elektrobau Muldingen GmbH · Headquarters Muldingen
County court Stuttgart · HRB 590142

Nominal data

Type	A4D350-AN08-24					
Motor	M4D074-DF					
Phase		3~	3~	3~	3~	3~
Nominal voltage	VAC	230	230	400	400	460
Connection		Δ	Δ	Y	Y	Y
Frequency	Hz	50	60	50	60	60
Type of data definition		ml	ml	ml	ml	ml
Valid for approval / standard		CE	CE	CE	CE	CE
Speed (rpm)	min ⁻¹	1370	1520	1370	1520	1600
Power input	W	170	230	170	230	255
Current draw	A	0.64	0.70	0.37	0.40	0.42
Max. back pressure	Pa	90	90	90	90	110
Min. ambient temperature	°C	-25	-25	-25	-25	-25
Max. ambient temperature	°C	65	55	65	55	55
Starting current	A	1.9	1.9	1.1	1.1	1.22

ml = Max. load · me = Max. efficiency · fa = Running at free air · cs = Customer specs · cu = Customer unit
Subject to alterations

Data according to ErP directive

		Actual	Request 2015		
01 Overall efficiency η_{es}	%	28.7	28.6	09 Power input P_e	kW 0.16
02 Measurement category	A			09 Air flow q_v	m ³ /h 2105
03 Efficiency category	Static			09 Pressure increase p_{fs}	Pa 82
04 Efficiency grade N	40.1	40		10 Speed (rpm) n	min ⁻¹ 1375
05 Variable speed drive	No			11 Specific ratio*	1.00

Data definition with optimum efficiency.
The ErP data is determined using a motor-impeller combination in a standardised measurement configuration.

* Specific ratio = $1 + p_g / 100\,000\text{ Pa}$

LU-131044



Technical features

Mass	3.3 kg
Size	350 mm
Surface of rotor	Coated in black
Material of blades	Press-fitted sheet steel blank, sprayed with PP plastic
Number of blades	5
Direction of air flow	"V"
Direction of rotation	Counter-clockwise, seen on rotor
Type of protection	IP 44; Depending on installation and position as per EN 60034-5 The IP protection is guaranteed only if the provided cable guard and terminal box are installed.
Insulation class	"F"
Humidity (F)/environmental protection class (H)	F2-2
Max. permissible ambient motor temp. (transp./ storage)	+ 80 °C
Min. permissible ambient motor temp. (transp./storage)	- 40 °C
Mounting position	Shaft horizontal or rotor on bottom; rotor on top on request
Condensate discharge holes	Rotor-side
Operation mode	S1
Motor bearing	Ball bearing
Touch current acc. IEC 60990 (measuring network Fig. 4, TN system)	< 0.75 mA
Electrical leads	Prepared for terminal box installation/assembly
Motor protection	Thermal overload protector (TOP) brought out, basic insulation
Cable exit	Variable
Protection class	I (if protective earth is connected by customer)
Product conforming to standard	EN 60335-1



AC axial fan

sickled blades (S series), single inlet

Product drawing

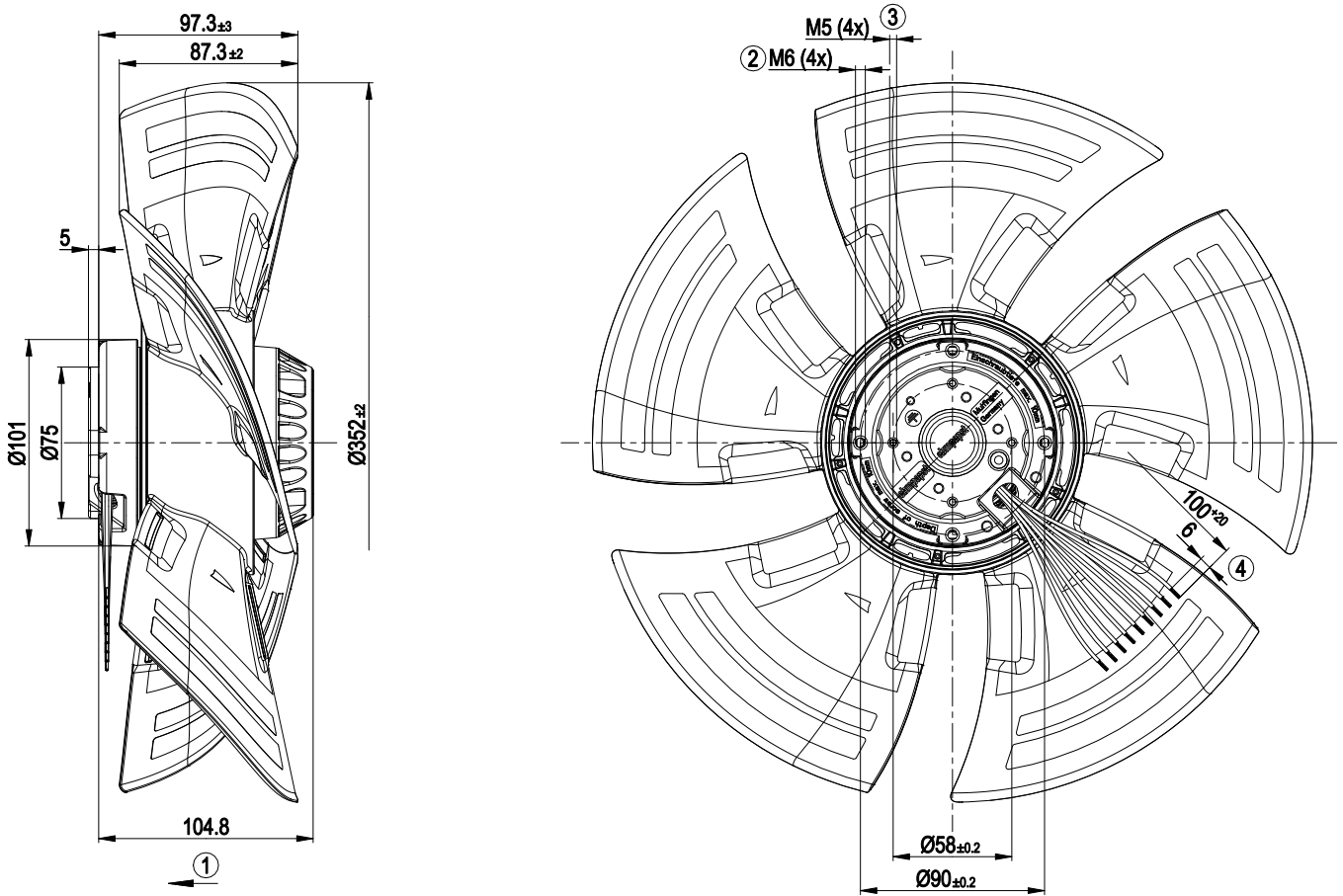

1	Direction of air flow "V"
2	Thread reach max. 10 mm
3	Thread reach max. 8 mm
4	Connection line halogen and silicone-free 9G 0.5 mm ² , 9x lead tips crimped



AC axial fan

sickled blades (S series), single inlet

Connection screen

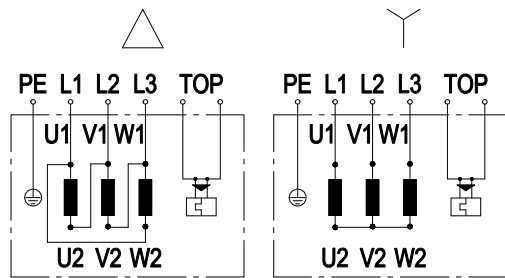

Note: Change in direction of rotation by reversing two phases

Δ	Delta connection	Y	Star connection	L1	black
L2	blue	L3	brown	U1	black
V1	blue	W1	brown	U2	green
V2	white	W2	yellow	TOP	2xgrey
PE	green/yellow				



Charts: Air flow 50 Hz

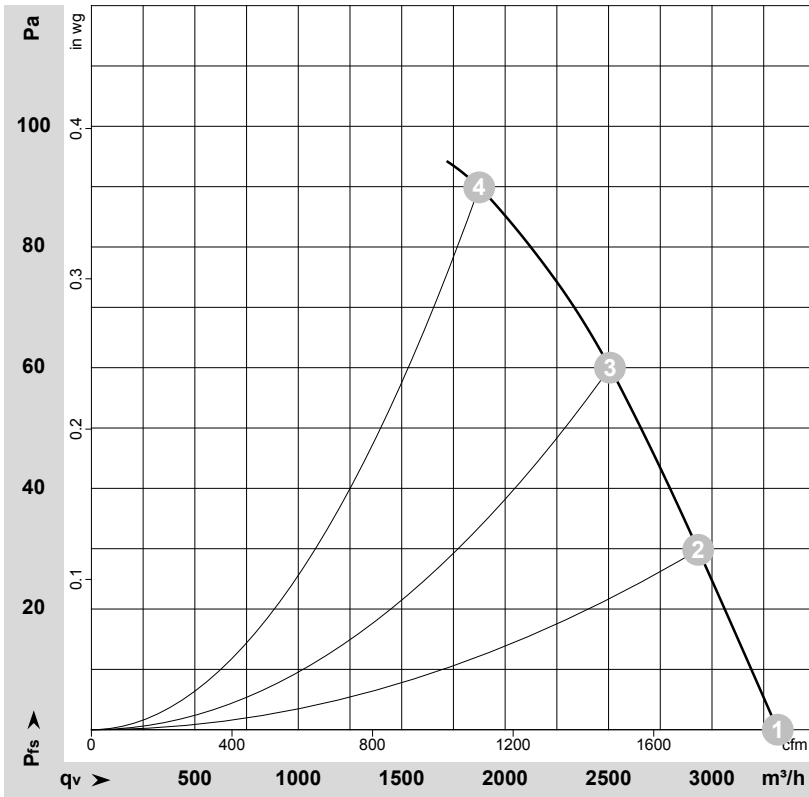

$\rho = 1.15 \text{ kg/m}^3 \pm 2 \%$

Measurement: LU-131044-1

Air performance measured as per ISO 5801 Installation category A. For detailed information on the measuring set-up, please contact ebmpapst. Suction-side noise levels: LwA measured as per ISO 13347 / LpA measured with 1m distance to fan axis. The values given are valid under the measuring conditions mentioned above and may vary according to the actual installation situation. With any deviation from the standard set-up, the specific values have to be checked and reviewed with the unit installed.

Measured values

	Conn.	U	f	n	Pe	I	LpA _{in}	LwA _{in}	qv	Pfs	qv	Pfs
		V	Hz	min ⁻¹	W	A	dB(A)	dB(A)	m ³ /h	Pa	cfm	inH ₂ O
1	Y	400	50	1405	136	0.34	61	69	3320	0	1955	0.00
2	Y	400	50	1395	148	0.35	59	66	2935	30	1725	0.12
3	Y	400	50	1380	158	0.35	56	64	2505	60	1475	0.24
4	Y	400	50	1370	170	0.37	56	64	1875	90	1105	0.36

Conn. = Connection · U = Supply voltage · f = Frequency · n = Speed (rpm) · Pe = Power input · I = Current draw · LpA_{in} = Sound pressure level inlet side · LwA_{in} = Sound power level inlet side
 qv = Air flow · p_{fs} = Pressure increase



AC axial fan

sickled blades (S series), single inlet

Charts: Air flow 60 Hz

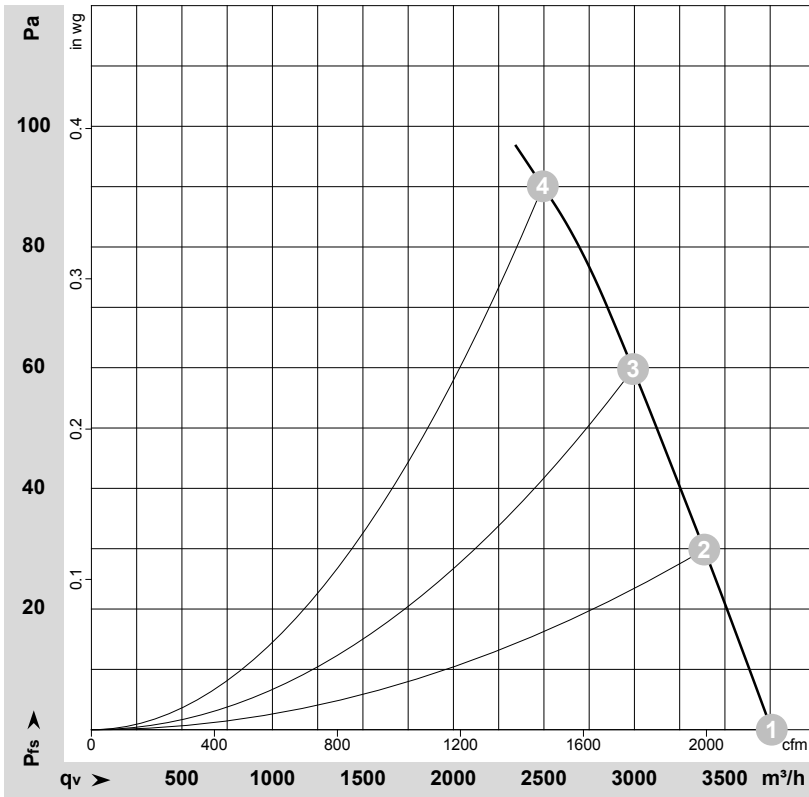

$\rho = 1.15 \text{ kg/m}^3 \pm 2 \%$

Measurement: LU-131047-1

Air performance measured as per ISO 5801 Installation category A. For detailed information on the measuring set-up, please contact ebmpapst. Suction-side noise levels: LwA measured as per ISO 13347 / LpA measured with 1m distance to fan axis. The values given are valid under the measuring conditions mentioned above and may vary according to the actual installation situation. With any deviation from the standard set-up, the specific values have to be checked and reviewed with the unit installed.

Measured values

	Conn.	U	f	n	P _e	I	LpA _{in}	LwA _{in}	q _v	P _{fs}	q _v	P _{fs}
		V	Hz	min ⁻¹	W	A	dB(A)	dB(A)	m ³ /h	Pa	cfm	inH ₂ O
1	Y	400	60	1595	184	0.33	64	72	3760	0	2210	0.00
2	Y	400	60	1575	200	0.35	62	69	3385	30	1995	0.12
3	Y	400	60	1550	215	0.37	60	67	2995	60	1760	0.24
4	Y	400	60	1520	230	0.40	58	66	2495	90	1470	0.36

Conn. = Connection · U = Supply voltage · f = Frequency · n = Speed (rpm) · P_e = Power input · I = Current draw · LpA_{in} = Sound pressure level inlet side · LwA_{in} = Sound power level inlet side
 q_v = Air flow · p_{fs} = Pressure increase

