



A4D350-AN08-13 ebmpapst Datasheet

sales@fansco.com

www.fansco.com

Limited partnership · Headquarters Muldingen

Amtsgericht (court of registration) Stuttgart · HRA 590344

General partner Elektrobau Muldingen GmbH · Headquarters Muldingen

Amtsgericht (court of registration) Stuttgart · HRB 590142



## Nominal data

Type	A4D350-AN08-13				
Motor	M4D074-DF				
Phase		3~	3~	3~	3~
Nominal voltage	VAC	230	230	400	400
Wiring		$\Delta$	$\Delta$	Y	Y
Frequency	Hz	50	60	50	60
Method of obtaining data		ml	ml	ml	ml
Valid for approval/standard		CE	CE	CE	CE
Speed (rpm)	min <sup>-1</sup>	1370	1520	1370	1520
Power consumption	W	170	230	170	230
Current draw	A	0.64	0.70	0.37	0.40
Max. back pressure	Pa	90	90	90	90
Max. back pressure	inH <sub>2</sub> O	0.36	0.36	0.36	0.36
Min. ambient temperature	°C	-25	-25	-25	-25
Max. ambient temperature	°C	65	55	65	55
Starting current	A	1.9	1.9	1.1	1.1

ml = Max. load · me = Max. efficiency · fa = Free air · cs = Customer specification · ce = Customer equipment  
Subject to change

## Data according to ErP Directive

		Actual	Req. 2015			
01 Overall efficiency $\eta_{es}$	%	28.7	28.6	09 Power consumption $P_e$	kW	0.16
02 Measurement category		A		09 Air flow $q_v$	m <sup>3</sup> /h	2105
03 Efficiency category		Static		09 Pressure increase $p_{fs}$	Pa	82
04 Efficiency grade N		40.1	40	10 Speed (rpm) n	min <sup>-1</sup>	1375
05 Variable speed drive		No		11 Specific ratio*		1.00

Data obtained at optimum efficiency level.  
The ErP data is determined using a motor-impeller combination in a standardized measurement setup.

\* Specific ratio =  $1 + p_g / 100\,000\text{ Pa}$ 

LU-131044



### Technical description

Weight	3.2 kg
Fan size	350 mm
Rotor surface	Painted black
Blade material	PP plastic
Number of blades	5
Airflow direction	"V"
Direction of rotation	Counterclockwise, viewed toward rotor
Degree of protection	IP44; installation- and position-dependent as per EN 60034-5. The degree of protection is only assured when the intended cable guard and terminal box are installed.
Insulation class	"F"
Moisture (F) / Environmental (H) protection class	H0+
Max. permitted ambient temp. for motor (transport/storage)	+ 80 °C
Min. permitted ambient temp. for motor (transport/storage)	- 40 °C
Installation position	Shaft horizontal or rotor on bottom; rotor on top on request
Condensation drainage holes	On rotor side
Mode	S1
Motor bearing	Ball bearing
Touch current according to IEC 60990 (measuring circuit Fig. 4, TN system)	< 0.75 mA
Electrical hookup	Prepared for terminal box installation
With cable	Variable
Protection class	I (with customer connection of protective earth)
Conformity with standards	EN 60335-1

## Product drawing

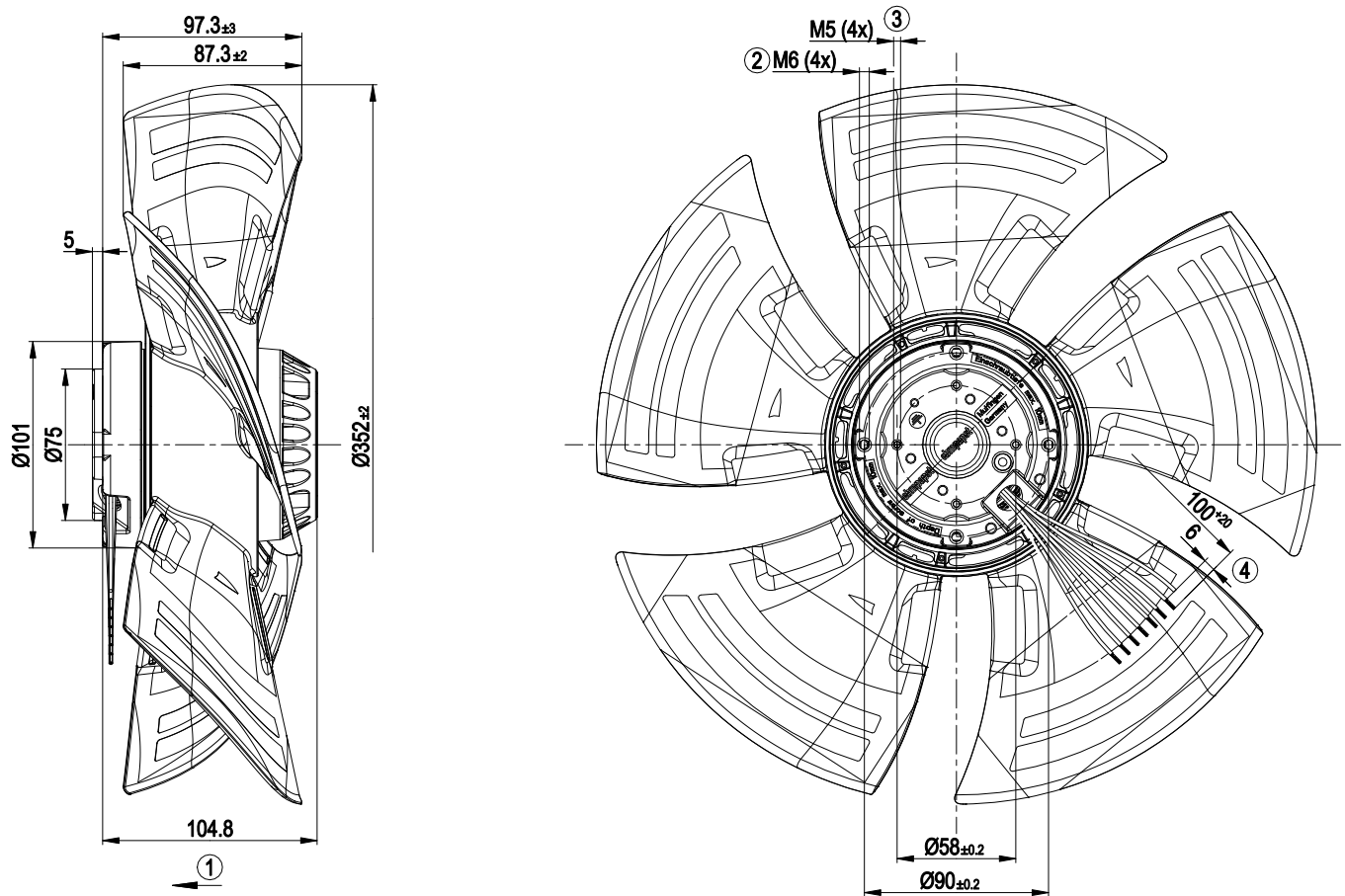

1	Direction of air flow "V"
2	Max. clearance for screw 10 mm
3	Max. clearance for screw 8 mm
4	Cable Dipotherm 7G 0.5 mm <sup>2</sup> , 7x crimped splice

## Connection diagram

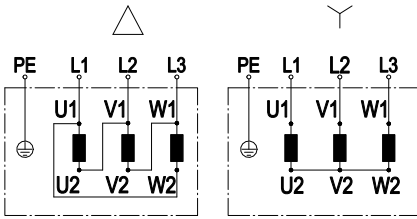

Change of rotation direction by reversing two phases

	Three-phase motor	Δ	Delta connection	Y	Star connection
L1	= U1 = black	L2	= V1 = blue	L3	= W1 = brown
U2	green	V2	white	W2	yellow
PE	green/yellow				

## Curves: Air performance 50 Hz

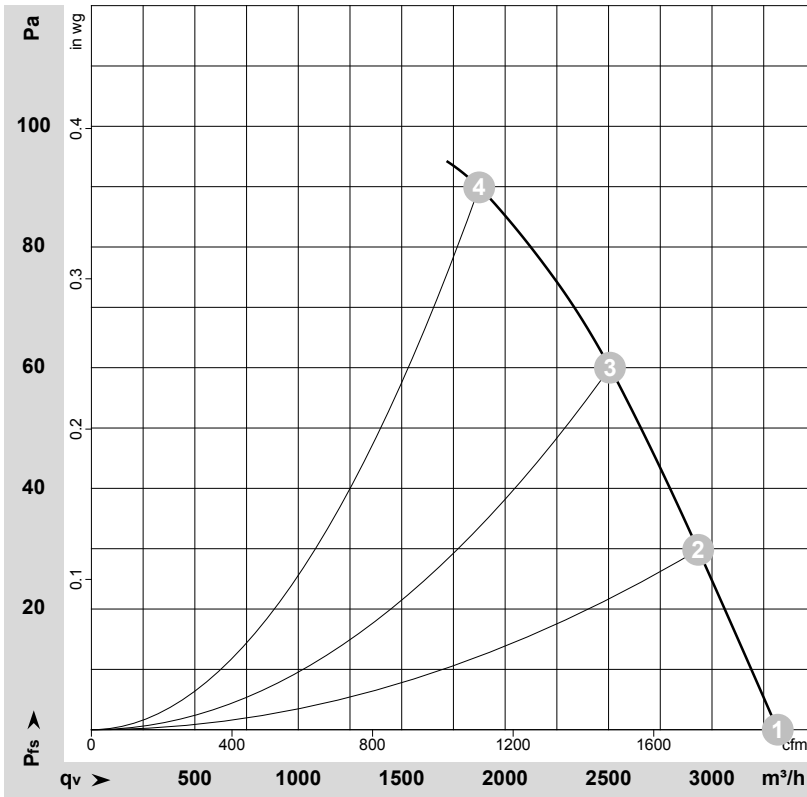

$\rho = 1.15 \text{ kg/m}^3 \pm 2 \%$

Measurement: LU-131044-1

Air performance measured according to ISO 5801 installation category A. For detailed information on the measurement setup, contact ebmpapst. Intake sound level: Sound power level according to ISO 13347 / sound pressure level measured at 1 m distance from fan axis. The values given are valid under the specified measuring conditions and may vary due to conditions of installation. For deviations from the standard configuration, the parameters have to be checked on the installed unit.

## Measured values

	Wired	U	f	n	P <sub>e</sub>	I	LpA <sub>in</sub>	LwA <sub>in</sub>	qv	P <sub>fs</sub>	qv	P <sub>fs</sub>
		V	Hz	min <sup>-1</sup>	W	A	dB(A)	dB(A)	m <sup>3</sup> /h	Pa	CFM	inH <sub>2</sub> O
1	Y	400	50	1405	136	0.34	61	69	3320	0	1955	0.00
2	Y	400	50	1395	148	0.35	59	66	2935	30	1725	0.12
3	Y	400	50	1380	158	0.35	56	64	2505	60	1475	0.24
4	Y	400	50	1370	170	0.37	56	64	1875	90	1105	0.36

Wired = Wiring · U = Power supply · f = Frequency · n = Speed (rpm) · P<sub>e</sub> = Power consumption · I = Current draw · LpA<sub>in</sub> = Sound pressure level intake side · LwA<sub>in</sub> = Sound power level intake side  
 qv = Air flow · P<sub>fs</sub> = Pressure increase



## Curves: Air performance 60 Hz

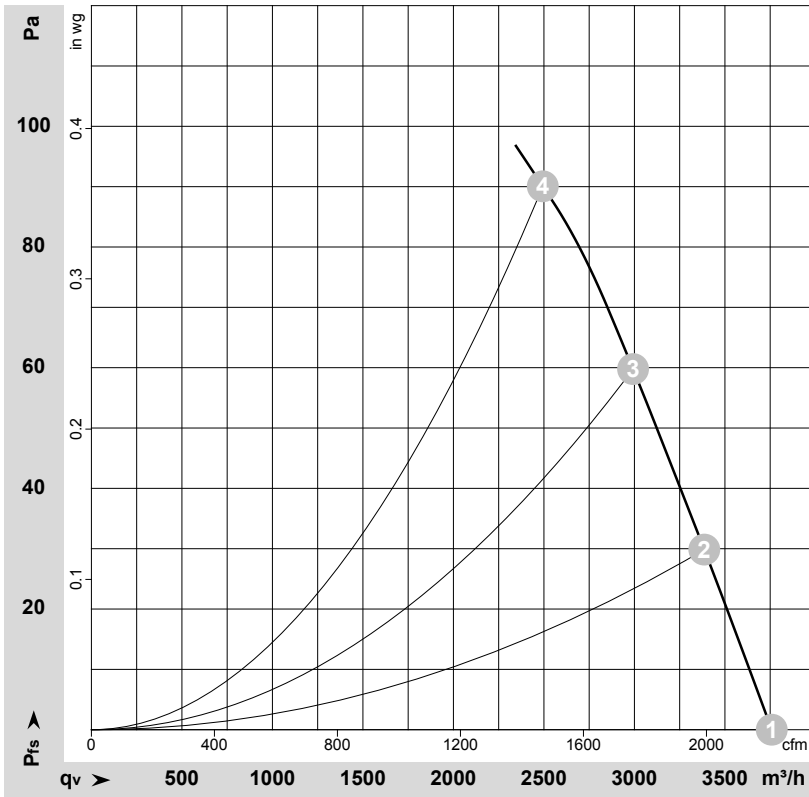

$\rho = 1.15 \text{ kg/m}^3 \pm 2 \%$

Measurement: LU-131047-1

Air performance measured according to ISO 5801 installation category A. For detailed information on the measurement setup, contact ebmpapst. Intake sound level: Sound power level according to ISO 13347 / sound pressure level measured at 1 m distance from fan axis. The values given are valid under the specified measuring conditions and may vary due to conditions of installation. For deviations from the standard configuration, the parameters have to be checked on the installed unit.

## Measured values

	Wired	U	f	n	P <sub>e</sub>	I	LpA <sub>in</sub>	LwA <sub>in</sub>	qv	P <sub>fs</sub>	qv	P <sub>fs</sub>
		V	Hz	min <sup>-1</sup>	W	A	dB(A)	dB(A)	m <sup>3</sup> /h	Pa	CFM	inH <sub>2</sub> O
1	Y	400	60	1595	184	0.33	64	72	3760	0	2210	0.00
2	Y	400	60	1575	200	0.35	62	69	3385	30	1995	0.12
3	Y	400	60	1550	215	0.37	60	67	2995	60	1760	0.24
4	Y	400	60	1520	230	0.40	58	66	2495	90	1470	0.36

Wired = Wiring · U = Power supply · f = Frequency · n = Speed (rpm) · P<sub>e</sub> = Power consumption · I = Current draw · LpA<sub>in</sub> = Sound pressure level intake side · LwA<sub>in</sub> = Sound power level intake side  
 qv = Air flow · P<sub>fs</sub> = Pressure increase

