

A4D350-AN08-09 ebmpapst Datasheet

sales@fansco.com

www.fansco.com

Limited partnership · Headquarters Mulfingen

Amtsgericht (court of registration) Stuttgart · HRA 590344

General partner Elektrobau Mulfingen GmbH · Headquarters Mulfingen

Amtsgericht (court of registration) Stuttgart · HRB 590142



## Nominal data

Type	A4D350-AN08-09		
Motor	M4D074-DF		
Phase		3~	3~
Nominal voltage	VAC	265	460
Wiring		$\Delta$	Y
Frequency	Hz	60	60
Method of obtaining data		ml	ml
Valid for approval/standard		CE	CE
Speed (rpm)	min <sup>-1</sup>	1600	1600
Power consumption	W	255	255
Current draw	A	0.73	0.42
Max. back pressure	Pa	110	110
Max. back pressure	inH <sub>2</sub> O	0.44	0.44
Min. ambient temperature	°C	-25	-25
Max. ambient temperature	°C	55	55
Starting current	A	1.95	1.22

ml = Max. load · me = Max. efficiency · fa = Free air · cs = Customer specification · ce = Customer equipment  
Subject to change

## Data according to ErP Directive

		Actual	Req. 2015			
01 Overall efficiency $\eta_{es}$	%	28.7	28.6	09 Power consumption $P_e$	kW	0.16
02 Measurement category		A		09 Air flow $q_v$	m <sup>3</sup> /h	2105
03 Efficiency category		Static		09 Pressure increase $p_{fs}$	Pa	82
04 Efficiency grade N		40.1	40	10 Speed (rpm) n	min <sup>-1</sup>	1375
05 Variable speed drive		No		11 Specific ratio*		1.00

Data obtained at optimum efficiency level.

The ErP data is determined using a motor-impeller combination in a standardized measurement setup.

\* Specific ratio =  $1 + p_g / 100\,000\text{ Pa}$ 

LU-131044



### Technical description

Weight	3.3 kg
Fan size	350 mm
Rotor surface	Painted black
Blade material	PP plastic
Number of blades	5
Airflow direction	"A"
Direction of rotation	Clockwise, viewed toward rotor
Degree of protection	IP44; installation- and position-dependent as per EN 60034-5
Insulation class	"F"
Moisture (F) / Environmental (H) protection class	F2-2
Max. permitted ambient temp. for motor (transport/storage)	+ 80 °C
Min. permitted ambient temp. for motor (transport/storage)	- 40 °C
Installation position	Shaft horizontal or rotor on bottom; rotor on top on request
Condensation drainage holes	On rotor side
Mode	S1
Motor bearing	Ball bearing
Touch current according to IEC 60990 (measuring circuit Fig. 4, TN system)	< 0.75 mA
Motor protection	Thermal overload protector (TOP) with basic insulation
With cable	Variable
Protection class	I (with customer connection of protective earth)
Conformity with standards	EN 60335-1; CE
Approval	UL 1004-1; CSA C22.2 No. 100

# AC axial fan

sickle-shaped blades (S series), single-intake

## Product drawing

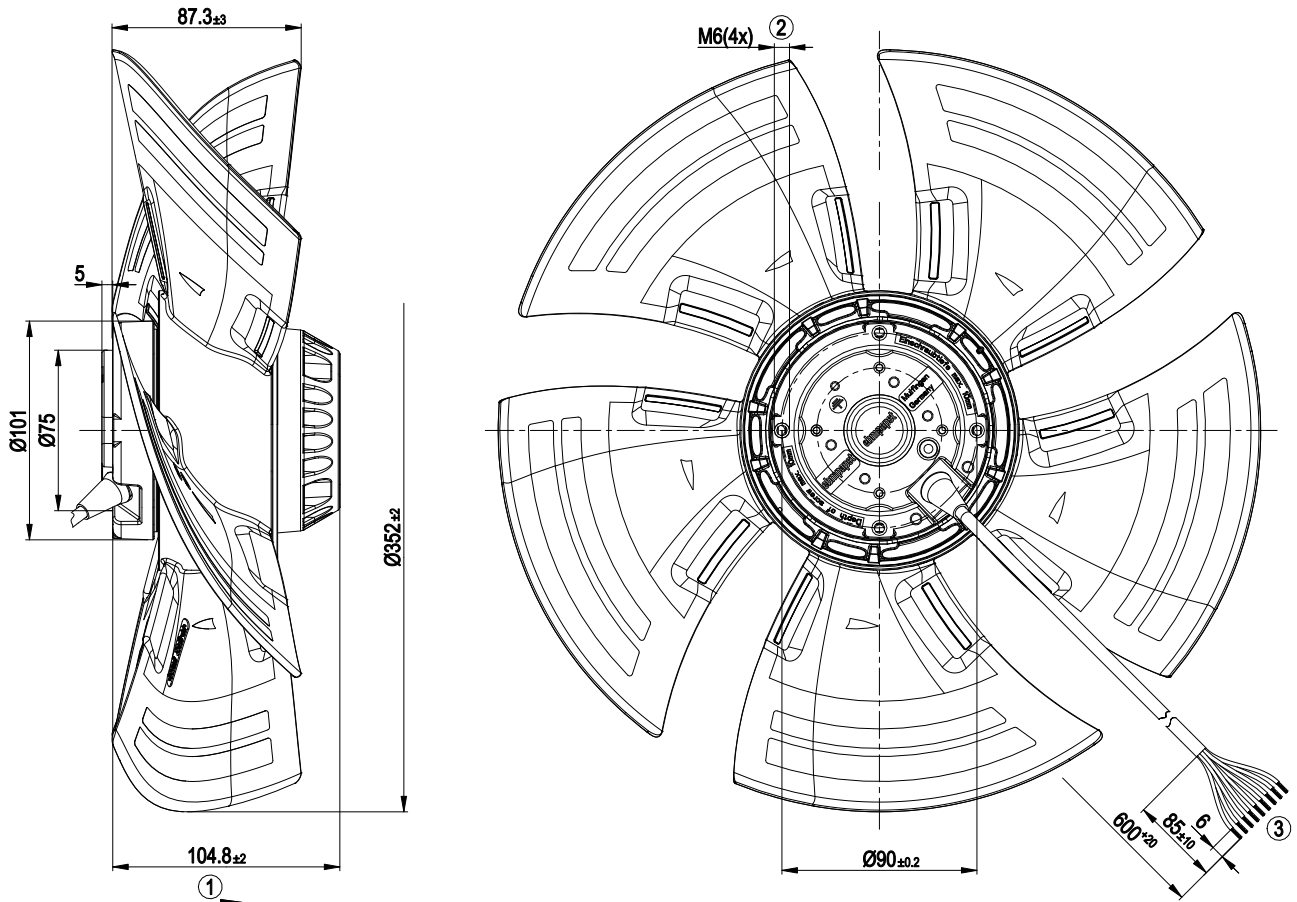

1	Direction of air flow "A"
2	Max. clearance for screw 10 mm
3	Cable PFA AWG20 (green/yellow AWG18), 9x crimped splices



# AC axial fan

sickle-shaped blades (S series), single-intake

## Connection diagram

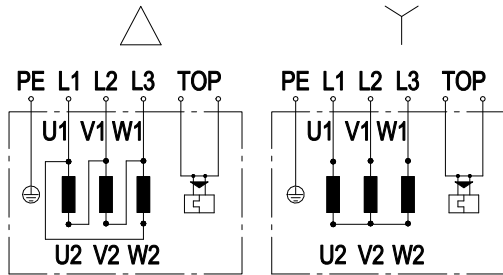

Note: Change of rotation direction by reversing two phases

Δ	Delta connection	Y	Star connection	L1	black
L2	blue	L3	brown	U1	black
V1	blue	W1	brown	U2	green
V2	white	W2	yellow	TOP	2x gray
PE	green/yellow				



## Curves: Air performance 60 Hz

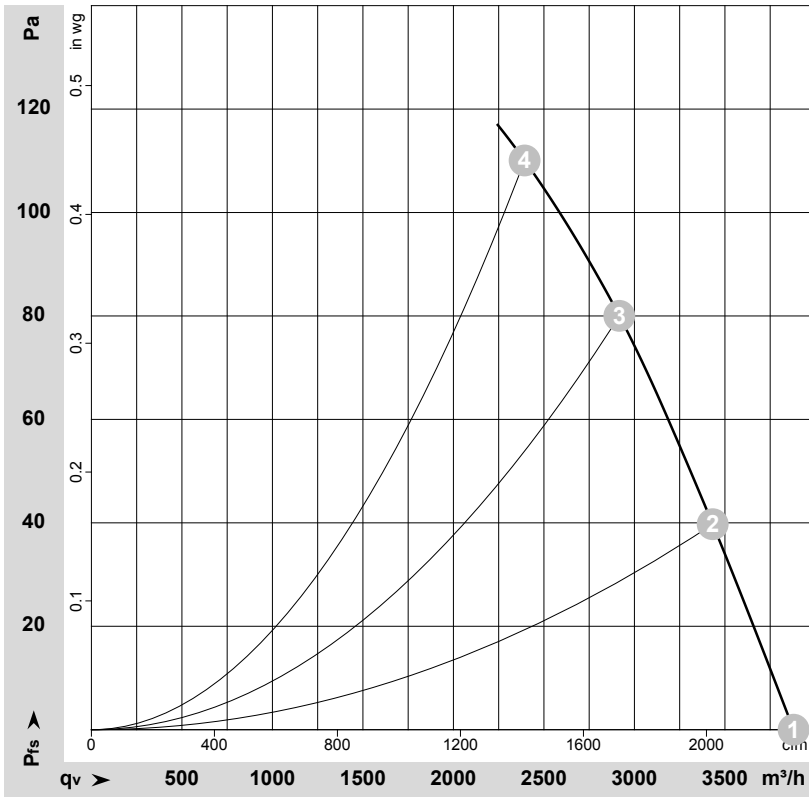

$\rho = 1.15 \text{ kg/m}^3 \pm 2 \%$

Measurement: LU-137385-1

Air performance measured according to ISO 5801 installation category A. For detailed information on the measurement setup, contact ebmpapst. Intake sound level: Sound power level according to ISO 13347 / sound pressure level measured at 1 m distance from fan axis. The values given are valid under the specified measuring conditions and may vary due to conditions of installation. For deviations from the standard configuration, the parameters have to be checked on the installed unit.

## Measured values

	Wired	U	f	n	P <sub>e</sub>	I	qv	p <sub>fs</sub>	qv	p <sub>fs</sub>
		V	Hz	min <sup>-1</sup>	W	A	m <sup>3</sup> /h	Pa	CFM	inH2O
1	Y	460	60	1655	199	0.37	3880	0	2285	0.00
2	Y	460	60	1635	219	0.39	3430	40	2020	0.16
3	Y	460	60	1615	238	0.40	2915	80	1715	0.32
4	Y	460	60	1600	255	0.42	2395	110	1410	0.44

Wired = Wiring · U = Power supply · f = Frequency · n = Speed (rpm) · P<sub>e</sub> = Power consumption · I = Current draw · qv = Air flow · p<sub>fs</sub> = Pressure increase