

AC axial fan

straight blades (A series)



A4D350-AA32-27 ebmpapst Datasheet
 sales@fansco.com
 www.fansco.com

Limited partnership · Headquarters Muldingen
 Amtsgericht (court of registration) Stuttgart · HRA 590344
 General partner Elektrobau Muldingen GmbH · Headquarters Muldingen
 Amtsgericht (court of registration) Stuttgart · HRB 590142



Nominal data

| | | | | |
|-----------------------------|-------------------|------|------|------|
| Type | A4D350-AA32-27 | | | |
| Motor | M4D068-EC | | | |
| Phase | | 3~ | 3~ | 3~ |
| Nominal voltage | VAC | 400 | 400 | 480 |
| Wiring | | Y | Y | Y |
| Frequency | Hz | 50 | 60 | 60 |
| Method of obtaining data | | fa | fa | fa |
| Valid for approval/standard | | CE | CE | CE |
| Speed (rpm) | min ⁻¹ | 1410 | 1620 | 1670 |
| Power consumption | W | 145 | 190 | 205 |
| Current draw | A | 0.38 | 0.36 | 0.41 |
| Min. ambient temperature | °C | -25 | -25 | -25 |
| Max. ambient temperature | °C | - | - | - |

ml = Max. load · me = Max. efficiency · fa = Free air · cs = Customer specification · ce = Customer equipment
 Subject to change

Data according to ErP Directive

| | | Actual | Req. 2015 |
|-----------------------------------|---|--------|-----------|
| 01 Overall efficiency η_{es} | % | 28.5 | 28.5 |
| 02 Measurement category | | A | |
| 03 Efficiency category | | Static | |
| 04 Efficiency grade N | | 40 | 40 |
| 05 Variable speed drive | | No | |

Data obtained at optimum efficiency level.
 The ErP data is determined using a motor-impeller combination in a standardized measurement setup.

| | | |
|-------------------------------|-------------------|------|
| 09 Power consumption P_e | kW | 0.15 |
| 09 Air flow q_v | m ³ /h | 2015 |
| 09 Pressure increase p_{fs} | Pa | 75 |
| 10 Speed (rpm) n | min ⁻¹ | 1390 |
| 11 Specific ratio* | | 1.00 |

* Specific ratio = $1 + p_{fs} / 100\,000\text{ Pa}$

LU-64797



Technical description

| | |
|--|--|
| Weight | 3.2 kg |
| Fan size | 350 mm |
| Rotor surface | Painted black |
| Impeller material | Sheet steel, painted black |
| Number of blades | 5 |
| Airflow direction | "V" |
| Direction of rotation | Counterclockwise, viewed toward rotor |
| Degree of protection | IP44; installation- and position-dependent as per EN 60034-5 |
| Insulation class | "F" |
| Moisture (F) / Environmental (H) protection class | F2-2 |
| Max. permitted ambient temp. for motor (transport/storage) | + 80 °C |
| Min. permitted ambient temp. for motor (transport/storage) | - 40 °C |
| Installation position | Shaft horizontal or rotor on bottom; rotor on top on request |
| Condensation drainage holes | On rotor side |
| Mode | S1 |
| Motor bearing | Ball bearing |
| Touch current according to IEC 60990 (measuring circuit Fig. 4, TN system) | < 0.75 mA |
| Motor protection | Thermal overload protector (TOP) with basic insulation |
| With cable | Lateral |
| Protection class | I (with customer connection of protective earth) |
| Conformity with standards | EN 60335-1; CE |
| Approval | CCC; UL 1004-1; CSA C22.2 No. 100 |

Product drawing

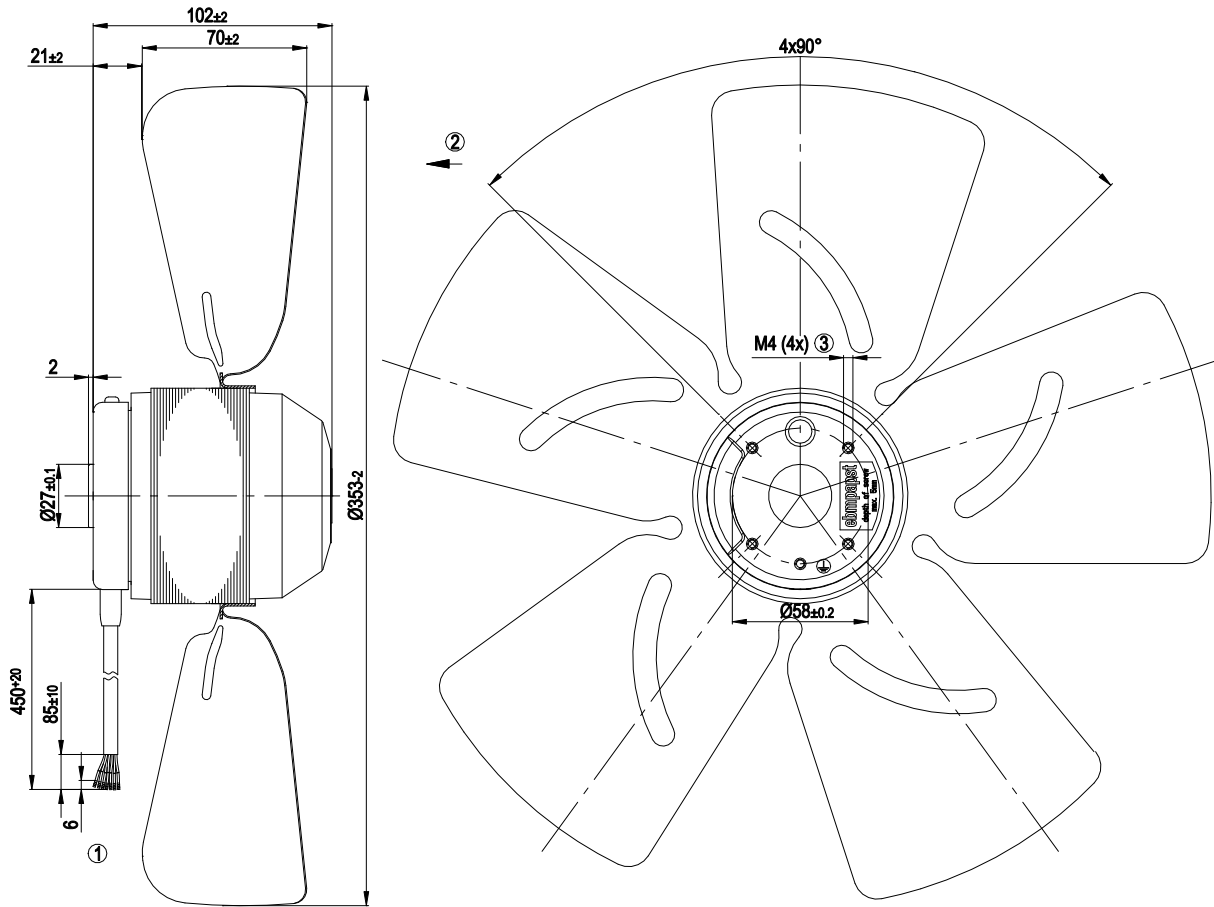

| | |
|---|---|
| 1 | Cable PFA 6G AWG20, 6 x crimped splices |
| 2 | Direction of air flow "V" |
| 3 | Max. clearance for screw 5 mm |



Connection diagram

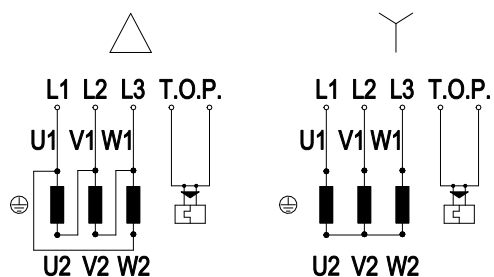

Note: Change of rotation direction by reversing two phases

| | | | | | |
|----|------------------|----|-----------------|-----|-------|
| Δ | Delta connection | Y | Star connection | L1 | black |
| L2 | blue | L3 | brown | U1 | black |
| V1 | blue | W1 | brown | U2 | green |
| V2 | white | W2 | yellow | TOP | gray |

Curves: Air performance 60 Hz Y

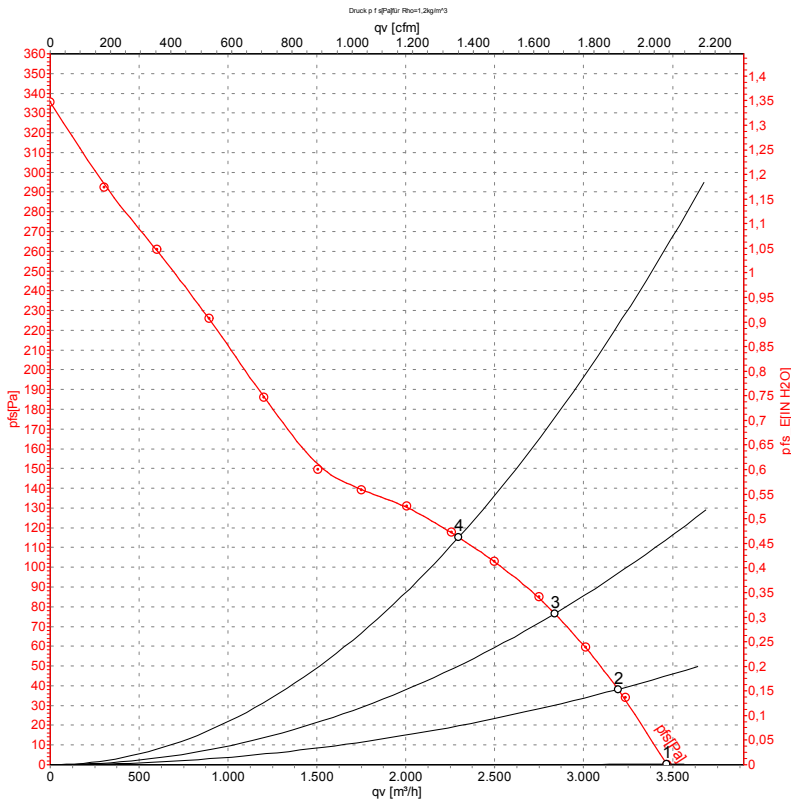

Measurement: LU-136181-1

Air performance measured according to ISO 5801 installation category A. For detailed information on the measurement setup, contact ebmpapst. Intake sound level: Sound power level according to ISO 13347 / sound pressure level measured at 1 m distance from fan axis. The values given are valid under the specified measuring conditions and may vary due to conditions of installation. For deviations from the standard configuration, the parameters have to be checked on the installed unit.

Measured values

| | Wired | U | f | n | P _e | I | qv | p _{fs} | qv | p _{fs} |
|---|-------|-----|----|-------------------|----------------|------|-------------------|-----------------|------|--------------------|
| | | V | Hz | min ⁻¹ | W | A | m ³ /h | Pa | CFM | inH ₂ O |
| 1 | Y | 460 | 60 | 1650 | 205 | 0.42 | 3465 | 0 | 2040 | 0.00 |
| 2 | Y | 460 | 60 | 1645 | 219 | 0.43 | 3190 | 40 | 1880 | 0.16 |
| 3 | Y | 460 | 60 | 1635 | 232 | 0.44 | 2835 | 75 | 1670 | 0.30 |
| 4 | Y | 460 | 60 | 1615 | 252 | 0.45 | 2295 | 115 | 1350 | 0.46 |

Wired = Wiring · U = Power supply · f = Frequency · n = Speed (rpm) · P_e = Power consumption · I = Current draw · qv = Air flow · p_{fs} = Pressure increase

