



A4D350-AA04-22 ebmpapst Datasheet  
 sales@fansco.com  
 www.fansco.com

Limited partnership · Headquarters Muldingen  
 Amtsgericht (court of registration) Stuttgart · HRA 590344

General partner Elektrobau Muldingen GmbH · Headquarters Muldingen  
 Amtsgericht (court of registration) Stuttgart · HRB 590142



## Nominal data

Type	A4D350-AA04-22		
Motor	M4D068-EC		
Phase		3~	3~
Nominal voltage	VAC	440	440
Wiring		Y	Y
Frequency	Hz	50	60
Method of obtaining data		fa	fa
Valid for approval/standard		CE	CE
Speed (rpm)	min <sup>-1</sup>	1400	1600
Power consumption	W	140	200
Current draw	A	0.31	0.3
Max. back pressure	Pa	100	120
Max. back pressure	inH <sub>2</sub> O	0.4	0.48
Min. ambient temperature	°C	-25	-25
Max. ambient temperature	°C	60	35
Starting current	A	0.95	0.85

ml = Max. load · me = Max. efficiency · fa = Free air · cs = Customer specification · ce = Customer equipment  
 Subject to change

## Data according to ErP Directive

		Actual	Req. 2015			
01 Overall efficiency $\eta_{es}$	%	31.2	28.5	09 Power consumption $P_e$	kW	0.15
02 Measurement category		A		09 Air flow $q_v$	m <sup>3</sup> /h	1790
03 Efficiency category		Static		09 Pressure increase $p_{fs}$	Pa	98
04 Efficiency grade N		42.7	40	10 Speed (rpm) n	min <sup>-1</sup>	1325
05 Variable speed drive		No		11 Specific ratio*		1.00

Data obtained at optimum efficiency level.  
 The ErP data is determined using a motor-impeller combination in a standardized measurement setup.

\* Specific ratio =  $1 + p_{fs} / 100\,000\text{ Pa}$

LU-138398



## Technical description

Weight	3.0 kg
Fan size	350 mm
Rotor surface	Painted black
Blade material	Sheet steel, painted black
Number of blades	5
Airflow direction	"A"
Direction of rotation	Clockwise, viewed toward rotor
Degree of protection	IP54; installation- and position-dependent as per EN 60034-5
Insulation class	"B"
Moisture (F) / Environmental (H) protection class	F2-2
Max. permitted ambient temp. for motor (transport/storage)	+ 80 °C
Min. permitted ambient temp. for motor (transport/storage)	- 40 °C
Installation position	Shaft horizontal or rotor on bottom; rotor on top on request
Condensation drainage holes	On rotor side
Mode	S1
Motor bearing	Ball bearing
Touch current according to IEC 60990 (measuring circuit Fig. 4, TN system)	< 0.75 mA
With cable	Lateral
Protection class	I (with customer connection of protective earth)
Conformity with standards	EN 60335-1, motor does not have factory-installed overheating protection

Product drawing

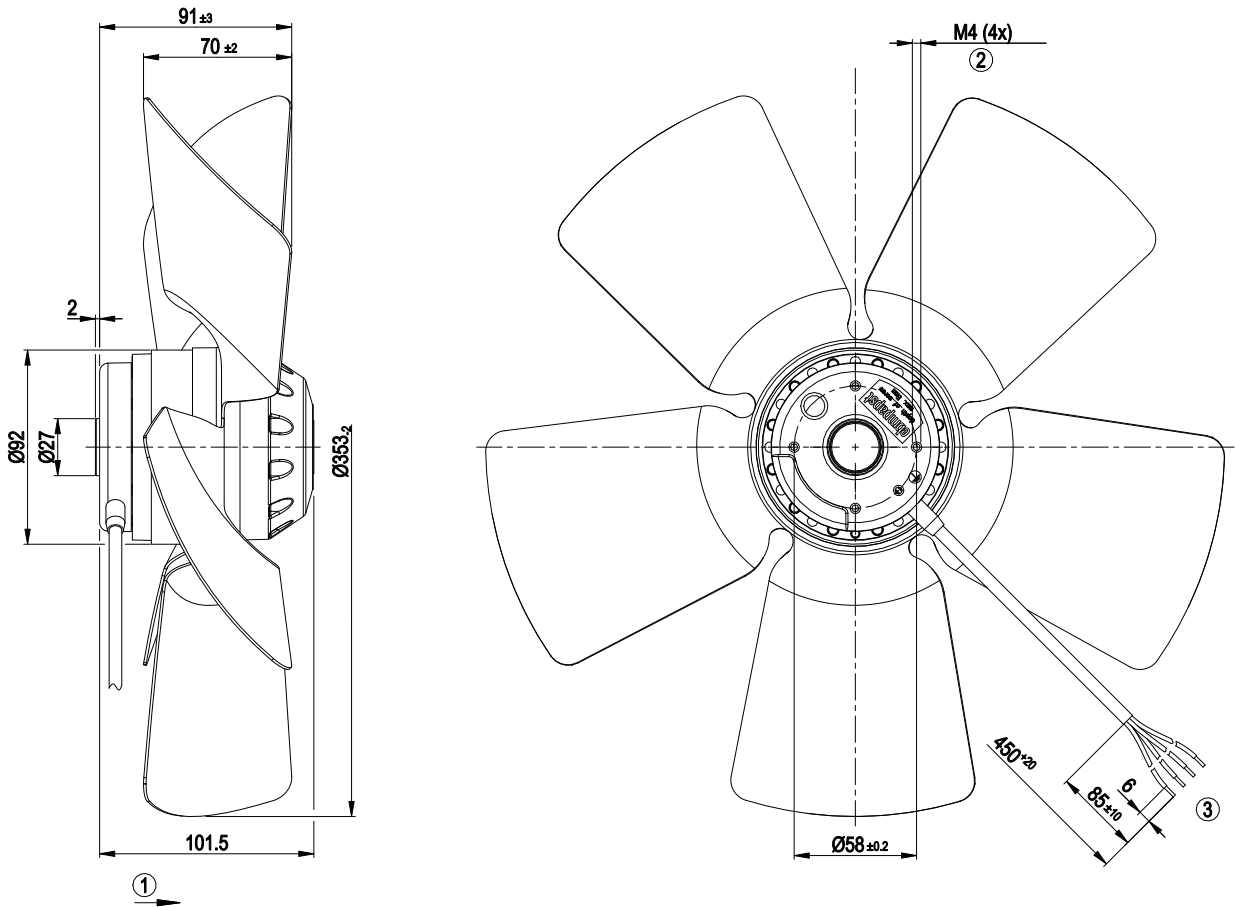

1	Direction of air flow "V"
2	Max. clearance for screw 5 mm
3	Cable silicone 4G 0.5 mm <sup>2</sup> , 4x crimped splices

## Connection diagram

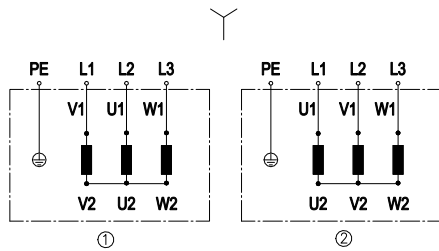

Change of rotation direction by reversing two phases

	Three-phase motor
Y	Star connection
1	Counterclockwise operation
L1	= V1 = blue
L2	= U1 = black
L3	= W1 = brown
2	Clockwise operation
L1	= U1 = black
L2	= V1 = blue
L3	= W1 = brown
PE	green/yellow

## Curves: Air performance 50 Hz

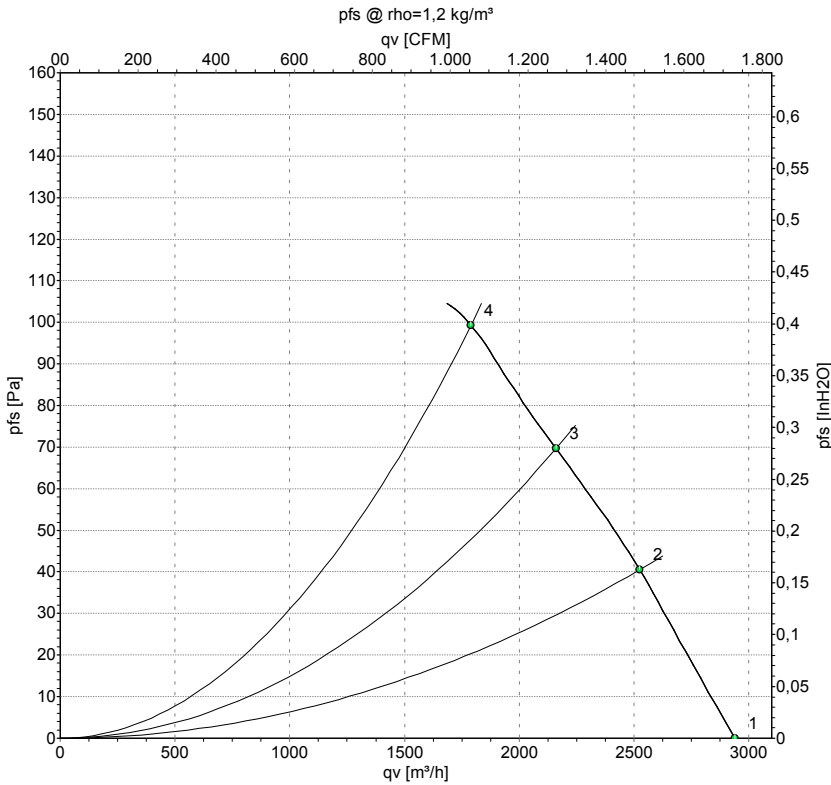

Measurement: LU-138398-1

Air performance measured according to ISO 5801 installation category A. For detailed information on the measurement setup, contact ebm-papst. Intake sound level: Sound power level according to ISO 13347 / sound pressure level measured at 1 m distance from fan axis. The values given are valid under the specified measuring conditions and may vary due to conditions of installation. For deviations from the standard configuration, the parameters have to be checked on the installed unit.

## Measured values

	Wired	U	f	n	P <sub>e</sub>	I	qv	p <sub>fs</sub>	qv	p <sub>fs</sub>
		V	Hz	min <sup>-1</sup>	W	A	m <sup>3</sup> /h	Pa	CFM	inH2O
1	Y	440	50	1400	140	0.31	2940	0	1730	0.00
2	Y	440	50	1355	140	0.31	2525	40	1485	0.16
3	Y	440	50	1345	143	0.31	2160	70	1270	0.28
4	Y	440	50	1325	155	0.31	1790	100	1055	0.40

Wired = Wiring · U = Power supply · f = Frequency · n = Speed (rpm) · P<sub>e</sub> = Power consumption · I = Current draw · qv = Air flow · p<sub>fs</sub> = Pressure increase



## Curves: Air performance 60 Hz

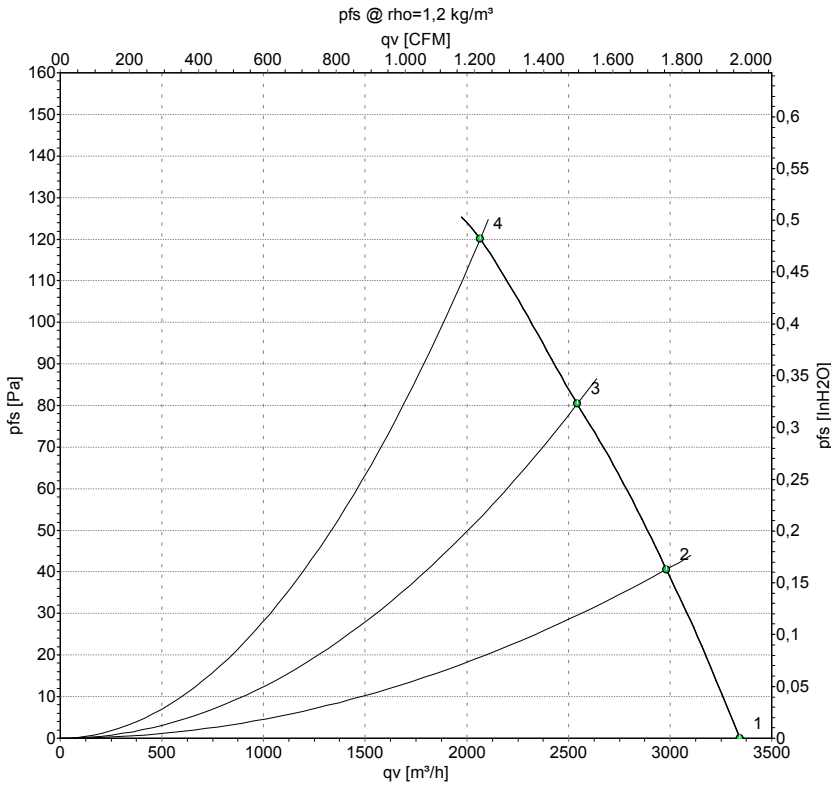

Measurement: LU-138403-1

Air performance measured according to ISO 5801 installation category A. For detailed information on the measurement setup, contact ebm-papst. Intake sound level: Sound power level according to ISO 13347 / sound pressure level measured at 1 m distance from fan axis. The values given are valid under the specified measuring conditions and may vary due to conditions of installation. For deviations from the standard configuration, the parameters have to be checked on the installed unit.

## Measured values

	Wired	U	f	n	P <sub>e</sub>	I	qv	p <sub>fs</sub>	qv	p <sub>fs</sub>
		V	Hz	min <sup>-1</sup>	W	A	m <sup>3</sup> /h	Pa	CFM	inH2O
1	Y	440	60	1600	200	0.30	3345	0	1970	0.00
2	Y	440	60	1545	200	0.32	2980	40	1755	0.16
3	Y	440	60	1520	213	0.34	2545	80	1495	0.32
4	Y	440	60	1490	229	0.36	2065	120	1215	0.48

Wired = Wiring · U = Power supply · f = Frequency · n = Speed (rpm) · P<sub>e</sub> = Power consumption · I = Current draw · qv = Air flow · p<sub>fs</sub> = Pressure increase

