

A4D300-AS34-10 ebmpapst Datasheet

sales@fansco.com

www.fansco.com

Limited partnership · Headquarters Muldingen

Amtsgericht (court of registration) Stuttgart · HRA 590344

General partner Elektrobau Muldingen GmbH · Headquarters Muldingen

Amtsgericht (court of registration) Stuttgart · HRB 590142

Nominal data

Type	A4D300-AS34-10					
Motor	M4D068-CF					
Phase		3~	3~	3~	3~	3~
Nominal voltage	VAC	400	400	460	480	480
Wiring		Y	Y	Y	Y	Y
Frequency	Hz	50	60	60	60	60
Method of obtaining data		ml	ml	ml	ml	ml
Valid for approval/standard		CE	CE	CE	CE	UL 2111
Speed (rpm)	min ⁻¹	1300	1400	1480	1510	1510
Power consumption	W	68	90	102	105	105
Current draw	A	0.14	0.15	0.16	0.16	0.16
Max. back pressure	Pa	60	70	80	80	80
Max. back pressure	inH ₂ O	0.24	0.28	0.32	0.32	0.32
Min. ambient temperature	°C	-25	-25	-25	-25	-25
Max. ambient temperature	°C	60	55	50	50	50

ml = Max. load · me = Max. efficiency · fa = Free air · cs = Customer specification · ce = Customer equipment

Subject to change



Technical description

Weight	1.6 kg
Fan size	300 mm
Rotor surface	Painted black
Blade material	PP plastic
Number of blades	5
Airflow direction	"V"
Direction of rotation	Counterclockwise, viewed toward rotor
Degree of protection	IP44; installation- and position-dependent as per EN 60034-5
Insulation class	"F"
Moisture (F) / Environmental (H) protection class	F2-2
Max. permitted ambient temp. for motor (transport/storage)	+ 80 °C
Min. permitted ambient temp. for motor (transport/storage)	- 40 °C
Installation position	Shaft horizontal or rotor on bottom; rotor on top on request
Condensation drainage holes	On rotor side
Mode	S1
Motor bearing	Ball bearing
Touch current according to IEC 60990 (measuring circuit Fig. 4, TN system)	< 0.75 mA
Motor protection	Thermal overload protector (TOP) with basic insulation
With cable	Lateral
Protection class	I (with customer connection of protective earth)
Conformity with standards	EN 60335-1; CE
Approval	CCC; UL 1004-1; CSA C22.2 No. 100

AC axial fan

sickle-shaped blades (S series)

Product drawing

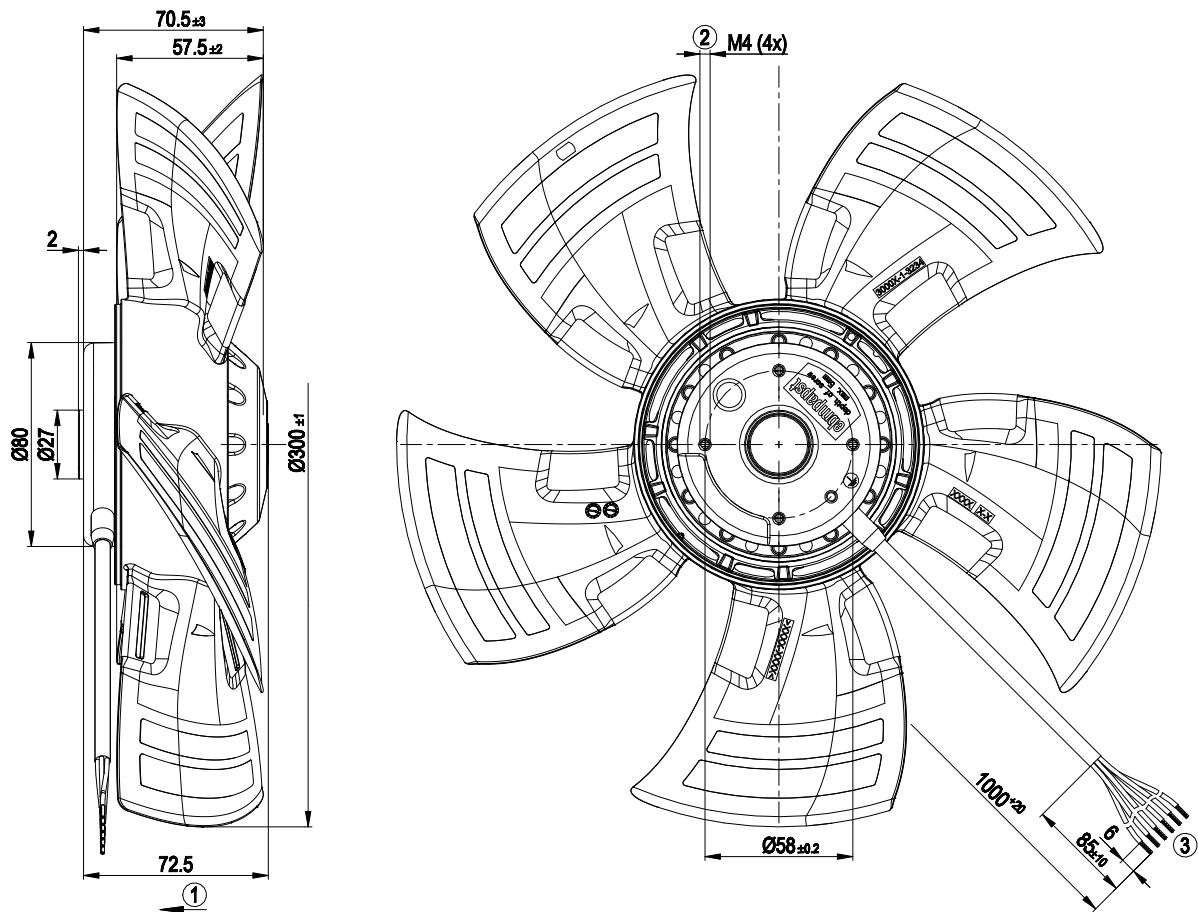

- | | |
|---|-------------------------------------|
| 1 | Direction of air flow "V" |
| 2 | Max. clearance for screw 5 mm |
| 3 | Cable PFA AWG20, 6x crimped splices |



Connection diagram

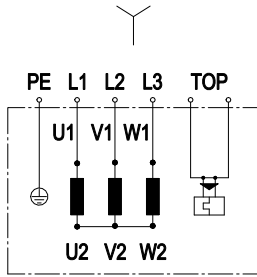

Note: Change of rotation direction by reversing two phases

Y	Star connection	L1	= U1 = black	L2	= V1 = blue
L3	= W1 = brown	PE	green/yellow	TOP	2x gray

Curves: Air performance 50 Hz

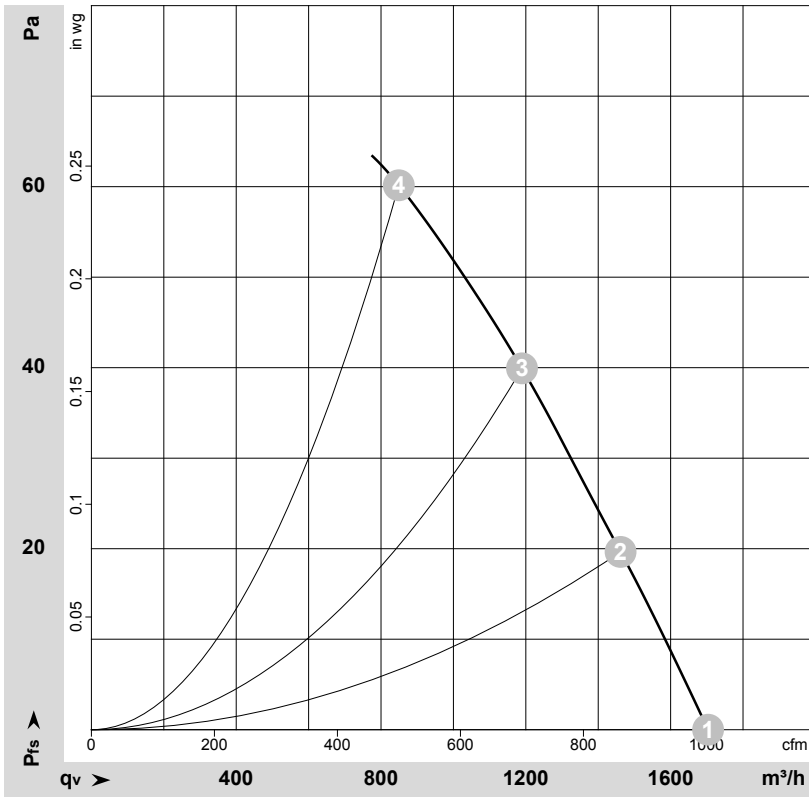

$\rho = 1.15 \text{ kg/m}^3 \pm 2 \%$

Measurement: LU-114649-1

Air performance measured according to ISO 5801 installation category A. For detailed information on the measurement setup, contact ebmpapst. Intake sound level: Sound power level according to ISO 13347 / sound pressure level measured at 1 m distance from fan axis. The values given are valid under the specified measuring conditions and may vary due to conditions of installation. For deviations from the standard configuration, the parameters have to be checked on the installed unit.

Measured values

	Wired	U	f	n	P _e	I	LpA _{in}	LwA _{in}	qv	p _{fs}	qv	p _{fs}
		V	Hz	min ⁻¹	W	A	dB(A)	dB(A)	m ³ /h	Pa	CFM	inH ₂ O
1	Y	400	50	1370	53	0.13	52	59	1705	0	1000	0.00
2	Y	400	50	1350	57	0.13	51	58	1460	20	860	0.08
3	Y	400	50	1335	61	0.13	51	58	1190	40	700	0.16
4	Y	400	50	1300	68	0.14	57	65	850	60	500	0.24

Wired = Wiring · U = Power supply · f = Frequency · n = Speed (rpm) · P_e = Power consumption · I = Current draw · LpA_{in} = Sound pressure level intake side · LwA_{in} = Sound power level intake side
 qv = Air flow · p_{fs} = Pressure increase



Curves: Air performance 60 Hz

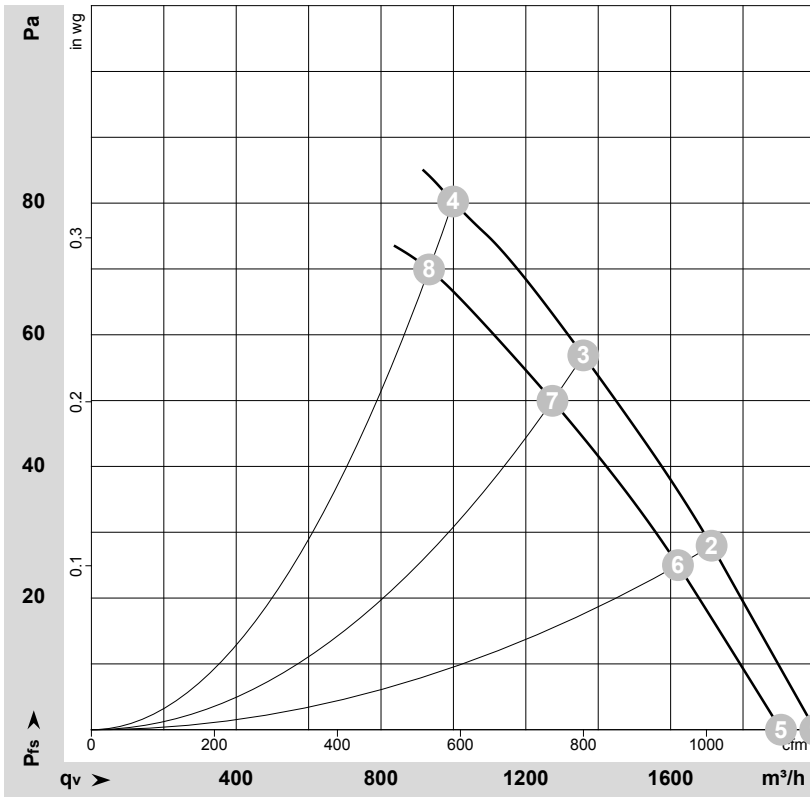

$\rho = 1.15 \text{ kg/m}^3 \pm 2 \%$

Measurement: LU-114654-1
Measurement: LU-114653-1

Air performance measured according to ISO 5801 installation category A. For detailed information on the measurement setup, contact ebm-papst. Intake sound level: Sound power level according to ISO 13347 / sound pressure level measured at 1 m distance from fan axis. The values given are valid under the specified measuring conditions and may vary due to conditions of installation. For deviations from the standard configuration, the parameters have to be checked on the installed unit.

Measured values

	Wired	U	f	n	P _e	I	LpA _{in}	LwA _{in}	qv	P _{fs}	qv	P _{fs}
		V	Hz	min ⁻¹	W	A	dB(A)	dB(A)	m ³ /h	Pa	CFM	inH ₂ O
1	Y	480	60	1605	79	0.14			2000	0	1175	0.00
2	Y	480	60	1580	86	0.14			1715	28	1010	0.11
3	Y	480	60	1560	92	0.15			1360	57	800	0.23
4	Y	480	60	1510	105	0.16			1000	80	590	0.32
5	Y	400	60	1530	69	0.13	55	62	1905	0	1120	0.00
6	Y	400	60	1495	75	0.13	54	61	1620	25	955	0.10
7	Y	400	60	1460	80	0.14	54	61	1275	50	750	0.20
8	Y	400	60	1400	90	0.15	60	68	935	70	550	0.28

Wired = Wiring · U = Power supply · f = Frequency · n = Speed (rpm) · P_e = Power consumption · I = Current draw · LpA_{in} = Sound pressure level intake side · LwA_{in} = Sound power level intake side
qv = Air flow · P_{fs} = Pressure increase

