



A3G910-AO83-03 ebmpapst Datasheet

sales@fansco.com

www.fansco.com

Limited partnership · Headquarters Muldingen

Amtsgericht (court of registration) Stuttgart · HRA 590344

General partner Elektrobau Muldingen GmbH · Headquarters Muldingen

Amtsgericht (court of registration) Stuttgart · HRB 590142



Nominal data

Type	A3G910-AO83-03	
Motor	M3G112-IA	
Phase		3~
Nominal voltage	VAC	400
Nominal voltage range	VAC	380 .. 480
Frequency	Hz	50/60
Method of obtaining data		ml
Status		prelim.
Speed (rpm)	min ⁻¹	610
Power consumption	W	625
Current draw	A	1.1
Max. back pressure	Pa	85
Max. back pressure	inH ₂ O	0.34
Min. ambient temperature	°C	-25
Max. ambient temperature	°C	60

ml = Max. load · me = Max. efficiency · fa = Free air · cs = Customer specification · ce = Customer equipment
Subject to change

Data according to ErP Directive

		Actual	Req. 2015			
01 Overall efficiency η_{es}	%	45.5	32.2	09 Power consumption P_{ed}	kW	0.59
02 Measurement category		A		09 Air flow q_v	m ³ /h	11680
03 Efficiency category		Static		09 Pressure increase p_{fs}	Pa	76
04 Efficiency grade N		53.3	40	10 Speed (rpm) n	min ⁻¹	615
05 Variable speed drive		Yes		11 Specific ratio*		1.00

Data obtained at optimum efficiency level.

The ErP data is determined using a motor-impeller combination in a standardized measurement setup.

* Specific ratio = $1 + p_g / 100\,000\text{ Pa}$

LU-120677



Technical description

Weight	12.4 kg
Fan size	910 mm
Rotor surface	Painted black
Electronics housing material	Die-cast aluminum, painted black
Blade material	Press-fitted sheet steel blank, sprayed with PP plastic
Number of blades	5
Blade pitch	0°
Airflow direction	"V"
Direction of rotation	Clockwise, viewed toward rotor
Degree of protection	IP54
Insulation class	"B"
Moisture (F) / Environmental (H) protection class	F4-1
Max. permitted ambient temp. for motor (transport/storage)	+ 80 °C
Min. permitted ambient temp. for motor (transport/storage)	- 40 °C
Installation position	Shaft horizontal or rotor on bottom; rotor on top on request
Condensation drainage holes	On rotor side
Mode	S1
Motor bearing	Ball bearing
Technical features	<ul style="list-style-type: none"> - Output 10 VDC, max. 10 mA - Output 20 VDC, max. 50 mA - Output for slave 0-10 V - Input for sensor 0-10 V or 4-20 mA - Alarm relay - Integrated PID controller - Motor current limitation - PFC, passive - RS-485 eBmBUS - Soft start - Control input 0-10 VDC / PWM - Control interface with SELV potential safely disconnected from supply - Thermal overload protection for electronics/motor - Line undervoltage / phase failure detection
EMC immunity to interference	According to EN 61000-6-2 (industrial environment)
EMC circuit feedback	According to EN 61000-3-2/3
EMC interference emission	According to EN 61000-6-3 (household environment)
Touch current according to IEC 60990 (measuring circuit Fig. 4, TN system)	<= 3.5 mA
Electrical hookup	Via terminal box
Motor protection	Thermal overload protector (TOP) internally connected
Protection class	I (with customer connection of protective earth)
Conformity with standards	EN 61800-5-1; CE

EC axial fan - HyBlade

sickle-shaped blades (S series)

Product drawing

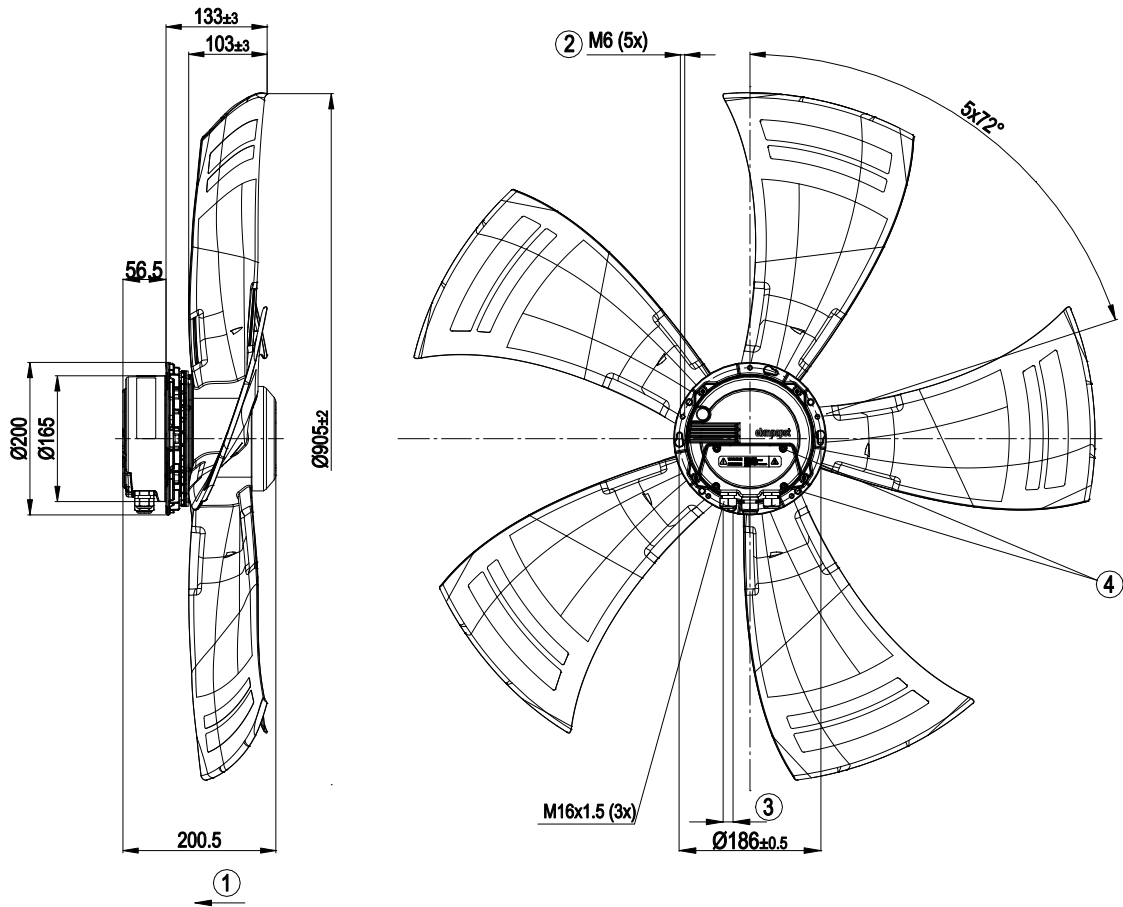

1	Direction of air flow "V"
2	Max. clearance for screw 16 mm
3	Cable diameter min. 4 mm, max. 10 mm; tightening torque 2.5±0.4 Nm
4	Tightening torque 3.5 ± 0.5 Nm



Connection diagram

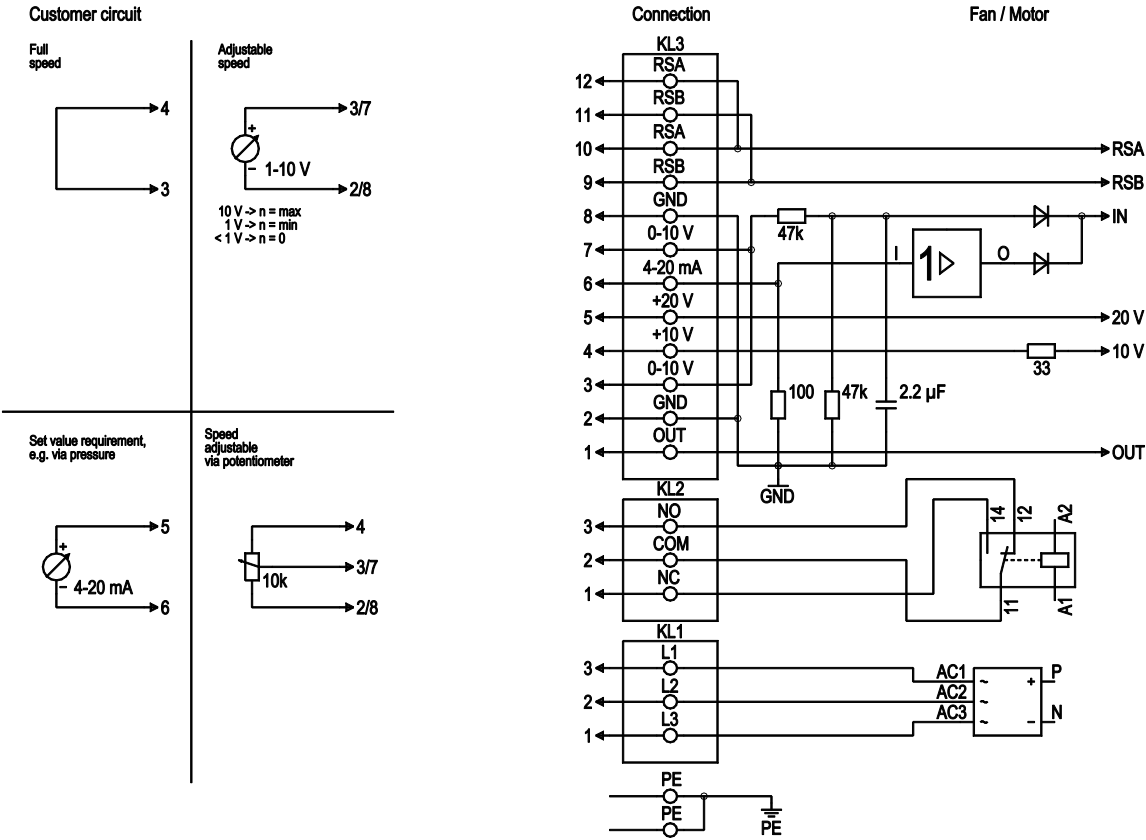

No.	Conn.	Designation	Function/assignment
PE		PE	Protective earth terminal
KL1	1, 2, 3	L1, L2, L3	Power supply 50/60 Hz
KL2	1	NC	Floating status contact, break for failure
KL2	2	COM	floating status contact, changeover contact, common connection (2 A, max. 250 VAC, min. 10 mA, AC1)
KL2	3	NO	Floating status contact, make for failure
KL3	1	OUT	Analog output, 0-10 VDC, max. 3 mA, SELV, output of current motor modulation level: 1 V corresponds to 10% modulation level. 10 V corresponds to 100% modulation level.
KL3	2, 8	GND	Reference ground for control interface, SELV
KL3	3, 7	0-10 V	Use control / current sensor value input 0-10 VDC, impedance 100 kΩ only as alternative to 4-20 mA input, SELV
KL3	4	+10 V	Voltage output 10 VDC (±3%), max. 10 mA, power supply for external devices (e.g. potentiometer), SELV
KL3	5	+20 V	Voltage output 20 VDC (+25%/-10%), max. 50 mA, power supply for external devices (e.g. sensors), SELV
KL3	6	4-20 mA	Use control / current sensor value input 4-20 mA, impedance 100 Ω only as alternative to 0-10 V input, SELV
KL3	9, 11	RSB	RS485 interface for ebmBUS, RSB, SELV
KL3	10, 12	RSA	RS485 interface for ebmBUS, RSA, SELV



Curves: Air performance 50 Hz

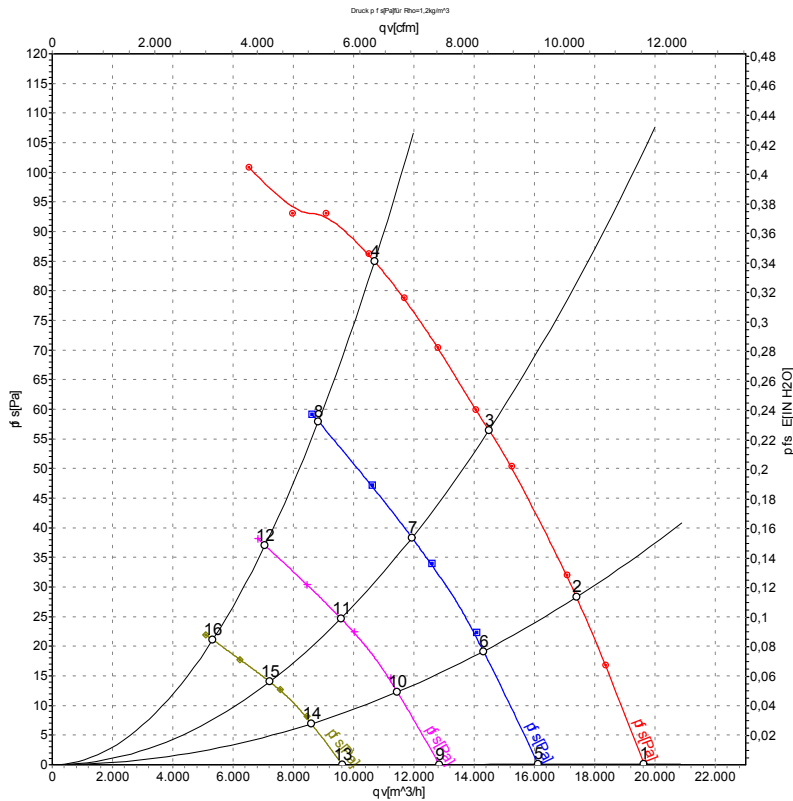

Measurement: LU-120677-1
 Measurement: LU-120687-1
 Measurement: LU-120688-1
 Measurement: LU-120689-1

Air performance measured according to ISO 5801 installation category A. For detailed information on the measurement setup, contact ebmpapst. Intake sound level: Sound power level according to ISO 13347 / sound pressure level measured at 1 m distance from fan axis. The values given are valid under the specified measuring conditions and may vary due to conditions of installation. For deviations from the standard configuration, the parameters have to be checked on the installed unit.

Measured values

	U	f	n	P _{ed}	I	LpA _{in}	LwA _{in}	LwA _{out}	qv	P _{fs}	qv	P _{fs}
	V	Hz	min ⁻¹	W	A	dB(A)	dB(A)	dB(A)	m ³ /h	Pa	CFM	inH ₂ O
1	400	50	610	380	0.69	60	68	67	19630	0	11555	0.00
2	400	50	610	463	0.77	59	66	65	17390	28	10235	0.11
3	400	50	610	541	0.89	58	66	65	14480	56	8525	0.22
4	400	50	610	625	1.10	62	70	70	10690	85	6290	0.34
5	400	50	505	213	0.43	56	62	61	16120	0	9490	0.00
6	400	50	505	259	0.51	55	61	60	14300	20	8415	0.08
7	400	50	505	300	0.57	55	61	60	11930	38	7020	0.15
8	400	50	505	340	0.63	56	63	63	8825	58	5195	0.23
9	400	50	405	120	0.28	50	56	56	12830	0	7550	0.00
10	400	50	405	143	0.32	52	56	55	11440	13	6735	0.05
11	400	50	405	165	0.35	50	55	54	9575	25	5635	0.10
12	400	50	405	185	0.38	50	57	57	7060	37	4155	0.15
13	400	50	305	63	0.18	41	47	47	9625	0	5665	0.00
14	400	50	305	71	0.20	43	49	49	8595	7	5060	0.03
15	400	50	305	80	0.21	42	48	48	7215	14	4245	0.06
16	400	50	305	89	0.22	42	48	49	5325	21	3135	0.08

U = Power supply · f = Frequency · n = Speed (rpm) · P_{ed} = Power consumption · I = Current draw · LpA_{in} = Sound pressure level intake side · LwA_{in} = Sound power level intake side
 LwA_{out} = Sound power level outlet side · qv = Air flow · p_{fs} = Pressure increase

