



A3G800-AO84-01 ebmpapst Datasheet

sales@fansco.com

www.fansco.com

Limited partnership · Headquarters Mulfingen
County court Stuttgart · HRA 590344

General partner: Elektrobau Mulfingen GmbH · Headquarters Mulfingen
County court Stuttgart · HRB 590142



Nominal data

Type	A3G800-AO84-01	
Motor	M3G112-IA	
Phase		3~
Nominal voltage	VAC	400
Nominal voltage range	VAC	380 .. 480
Frequency	Hz	50/60
Type of data definition		ml
Speed	min ⁻¹	735
Power input	W	835
Current draw	A	1.4
Min. ambient temperature	°C	-25
Max. ambient temperature	°C	60

ml = max. load · me = max. efficiency · fa = running at free air · cs = customer specs · cu = customer unit
Subject to alterations

Data according to ErP directive

Installation category	A
Efficiency category	Static
Variable speed drive integrated	Integrated
Specific ratio*	1,00

* Specific ratio = $1 + p_b / 100\,000\text{ Pa}$

	Actual	Request 2013	Request 2015
Overall efficiency η_{es}	44,2	29	33
Efficiency grade N	51,2	36	40
Power input P_{ed}	kW	0,78	
Air flow q_v	m ³ /h	12095	
Pressure increase p_{fs}	Pa	95	
Speed n	min ⁻¹	740	

Data established at point of optimum efficiency



Technical features

Mass	12 kg
Size	800 mm
Surface of rotor	Coated in black
Material of electronics housing	Die-cast aluminium, coated in black
Material of blades	Press-fitted sheet steel blank, sprayed with PP plastic
Number of blades	5
Direction of air flow	"V"
Direction of rotation	Clockwise, seen on rotor
Type of protection	IP 54
Insulation class	"B"
Humidity class	F4-1
Max. permissible ambient motor temp. (transp./ storage)	+80 °C
Min. permissible ambient motor temp. (transp./storage)	-40 °C
Mounting position	Shaft horizontal or rotor on bottom
Condensate discharge holes	Rotor-side
Operation mode	S1
Motor bearing	Ball bearing
Technical features	<ul style="list-style-type: none"> - PFC, passive - Control input 0-10 VDC / PWM - Over-temperature protected electronics / motor - Alarm relay - Integrated PID controller - Motor current limit - Soft start - Line undervoltage / phase failure detection - Output 10 VDC, max. 10 mA
EMC interference immunity	Acc. to EN 61000-6-2
EMC interference emission	Acc. to EN 61000-6-3
EMC harmonics	Acc. to EN 61000-3-2/3
Leakage current	<= 3.5 mA
Motor protection	Thermal overload protector (TOP) wired internally
Protection class	I (if protective earth is connected by customer)
Product conforming to standard	EN 61800-5-1
Approval	CCC

Product drawing

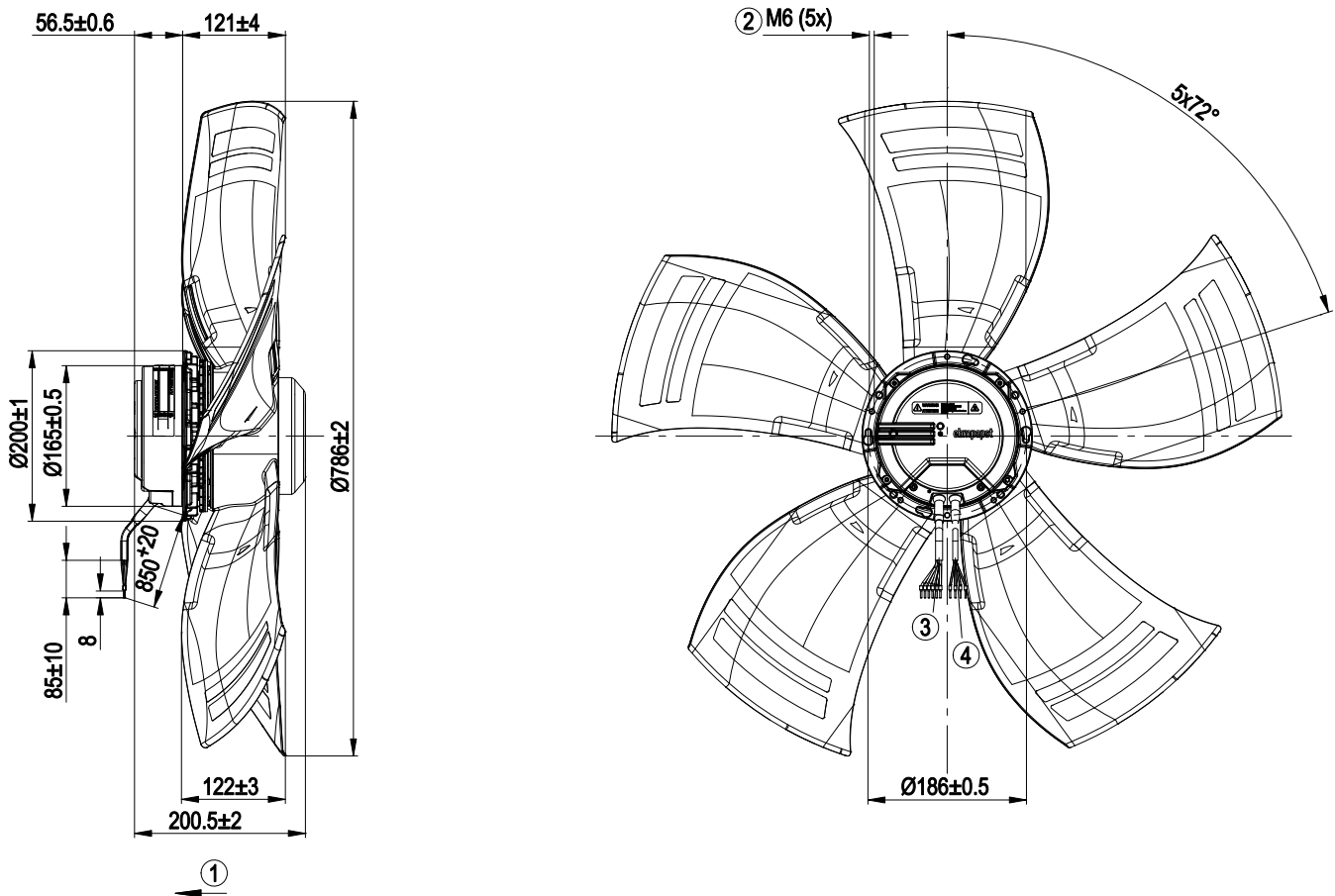

1	Direction of air flow "V"
2	Depth of screw 12-16 mm
3	Connection line PVC AWG18, 6x crimped core-end sleeves
4	Connection line PVC AWG22, 3x crimped core-end sleeves



Connection screen

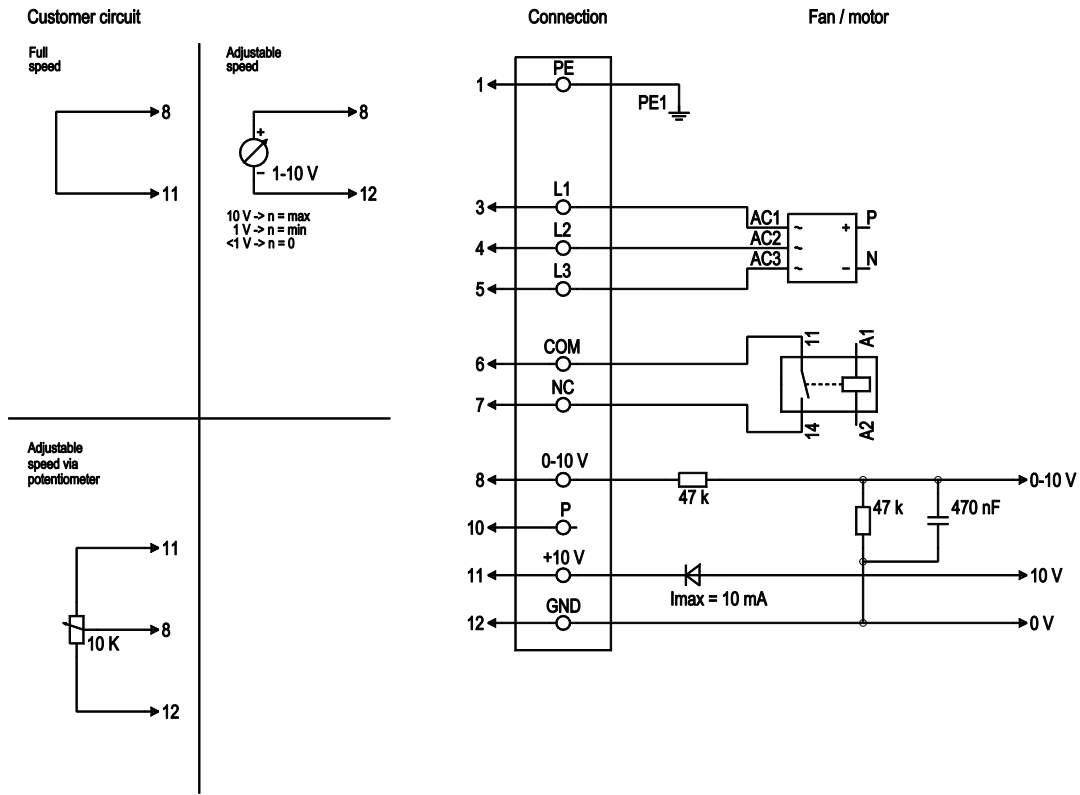

Line	No.	Signal	Colour	Function / assignment
1	1	PE	green/yellow	Ground wire
1	3	L1	black	Supply voltage, 50/60 Hz
1	4	L2	black	Supply voltage, 50/60 Hz
1	5	L3	black	Supply voltage, 50/60 Hz
1	6	COM	white 1	Floating status message contact, normally closed connection (2 A, max. 250 VAC, min. 10 mA, AC1)
1	7	NC	white 2	Floating status message contact, normally closed connection
2	8	0-10 V	yellow	Control input, set value 0-10 VDC, impedance 100 kΩ, SELV
2	10	P	orange	Do not use
2	11	+10 V	red	Voltage output 10 VDC (+/-3%), max. 10 mA, supply voltage for external devices (e.g. potentiometer), SELV
2	12	GND	blue	Reference mass for control interface, SELV

Charts: Air flow 50 Hz

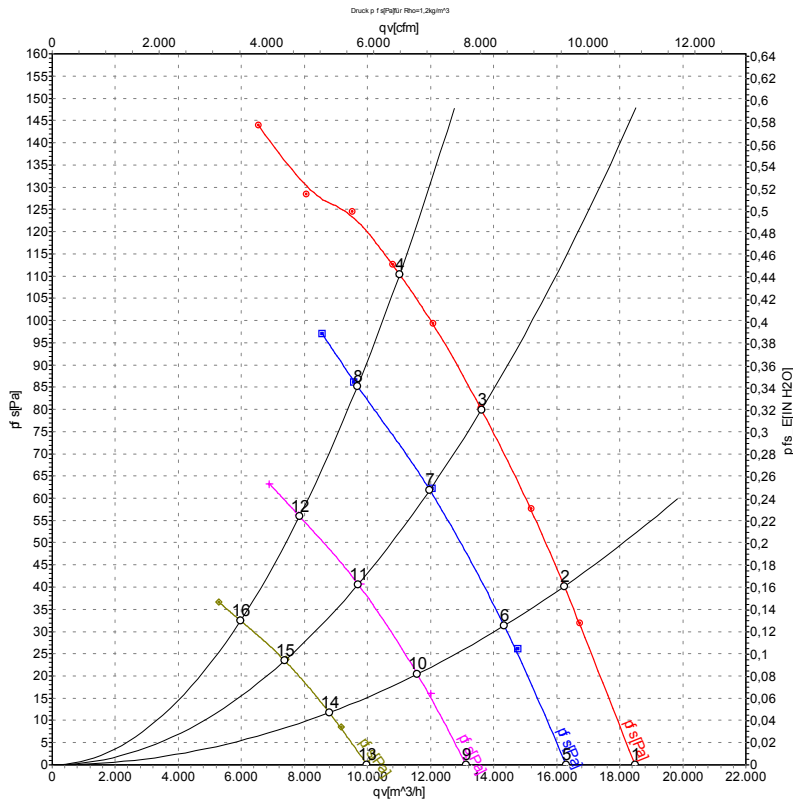

Measurement: LU-117968
 Measurement: LU-118106
 Measurement: LU-118107
 Measurement: LU-118105

Air performance measured as per ISO 5801 Installation category A. For detailed information on the measuring set-up, please contact ebm-papst. Suction-side noise levels: LwA measured as per ISO 13347 / LpA measured with 1m distance to fan axis. The values given are valid under the measuring conditions mentioned above and may vary according to the actual installation situation. With any deviation from the standard set-up, the specific values have to be checked and reviewed with the unit installed.

Measured values

	U	f	n	P _{ed}	I	LpA _{in}	LwA _{in}	LwA _{out}	qv	P _{fs}
	V	Hz	min ⁻¹	W	A	dB(A)	dB(A)	dB(A)	m ³ /h	Pa
1	400	50	735	514	0.87	63	70	70	18480	0
2	400	50	735	632	1.04	59	66	65	16240	40
3	400	50	735	732	1.20	57	64	64	13610	80
4	400	50	735	835	1.40	62	70	69	11020	110
5	400	50	650	338	0.66	59	66	66	16290	0
6	400	50	650	398	0.77	57	63	63	14330	32
7	400	50	650	476	0.86	54	61	60	11970	63
8	400	50	650	521	0.89	58	66	66	9685	85
9	400	50	525	185	0.39	54	61	60	13120	0
10	400	50	525	223	0.46	52	58	58	11580	21
11	400	50	525	253	0.51	49	56	55	9705	41
12	400	50	525	276	0.55	53	60	60	7845	56
13	400	50	400	90	0.23	48	54	54	9985	0
14	400	50	400	107	0.26	46	52	52	8785	12
15	400	50	400	120	0.28	43	50	50	7375	24
16	400	50	400	127	0.29	45	52	52	5975	32

