

A3G710-AS21-03 ebmpapst Datasheet

sales@fansco.com

www.fansco.com

Limited partnership · Headquarters Muldingen

Amtsgericht (court of registration) Stuttgart · HRA 590344

General partner Elektrobau Muldingen GmbH · Headquarters Muldingen

Amtsgericht (court of registration) Stuttgart · HRB 590142

## Nominal data

Type	A3G710-AS21-03	
Motor	M3G150-FF	
Phase		3~
Nominal voltage	VAC	400
Nominal voltage range	VAC	380 .. 480
Frequency	Hz	50/60
Method of obtaining data		ml
Speed (rpm)	min <sup>-1</sup>	1170
Power consumption	W	2400
Current draw	A	3.7
Max. back pressure	Pa	240
Max. back pressure	in. wg	0.96
Min. ambient temperature	°C	-40
Max. ambient temperature	°C	60

ml = Max. load · me = Max. efficiency · fa = Free air · cs = Customer specification · ce = Customer equipment  
Subject to change

## Data according to Commission Regulation (EU) 327/2011 (EN 17166)

		Actual	Req. 2015			
01 Overall efficiency $\eta_{es}$	%	42.7	36.1	09 Power consumption $P_{ed}$	kW	2.39
02 Measurement category		A		09 Air flow $q_v$	m <sup>3</sup> /h	14060
03 Efficiency category		Static		09 Pressure increase $p_{fs}$	Pa	247
04 Efficiency grade N		46.6	40	10 Speed (rpm) n	min <sup>-1</sup>	1175
05 Variable speed drive		Yes		11 Specific ratio*		1.00

Data obtained at optimum efficiency level.

\* Specific ratio =  $1 + p_{fs} / 100\,000\text{ Pa}$ 

LU-203012

The efficiency values displayed for achieving conformity with the Ecodesign Regulation EU 327/2011 has been reached with defined air duct components (e.g. inlet rings).  
The dimensions must be requested from ebm-papst. If other air conduction geometries are used on the installation side, the ebm-papst evaluation loses its validity/the conformity must be confirmed again.  
The product does not fall within the scope of Regulation (EU) 2019/1781 due to the exception specified in Article 2 (2a) (motors completely integrated into a product).



## Technical description

Size	710 mm
Motor size	150
Rotor surface	Painted black
Electronics housing material	Die-cast aluminum, painted gray
Blade material	Sheet aluminum insert, sprayed with PP plastic
Number of blades	5
Blade pitch	0°
Airflow direction	V
Direction of rotation	Clockwise, viewed toward rotor
Degree of protection	IP55
Insulation class	"F"
Moisture (F) / Environmental (H) protection class	H2
Ambient temperature note	Occasional start-up at temperatures between -40°C and -25°C is permitted. For continuous operation at ambient temperatures below -25°C (such as refrigeration applications), use must be made of a fan design with special low-temperature bearings.
Max. permitted ambient temp. for motor (transport/storage)	+80 °C
Min. permitted ambient temp. for motor (transport/storage)	-40 °C
Installation position	Shaft horizontal or rotor on bottom; rotor on top on request
Condensation drainage holes	On rotor side
Mode	S1
Motor bearing	Ball bearing
Technical features	<ul style="list-style-type: none"> <li>- Operation and alarm display with LED</li> <li>- External 15-50 VDC input (parameterization)</li> <li>- Alarm relay</li> <li>- Integrated PI controller</li> <li>- Configurable inputs/outputs (I/O)</li> <li>- MODBUS V6.3</li> <li>- Motor current limitation</li> <li>- RS-485 MODBUS-RTU</li> <li>- Soft start</li> <li>- Voltage output 3.3-24 VDC, Pmax = 800 mW</li> <li>- Control interface with SELV potential safely disconnected from the mains</li> <li>- Thermal overload protection for electronics/motor</li> <li>- Line undervoltage / phase failure detection</li> </ul>
EMC immunity to interference	According to EN 61000-6-2 (industrial environment)
EMC interference emission	According to EN 61000-6-4 (industrial environment)
Touch current according to IEC 60990 (measuring circuit Fig. 4, TN system)	<= 3.5 mA
Electrical hookup	Terminal box
Motor protection	Reverse polarity and locked-rotor protection
Protection class	I (with customer connection of protective earth)
Conformity with standards	EN 61800-5-1; UKCA; CE
Approval	EAC; UL 1004-7 + 60730-1; CSA C22.2 No. 77 + CAN/CSA-E60730-1

## Product drawing

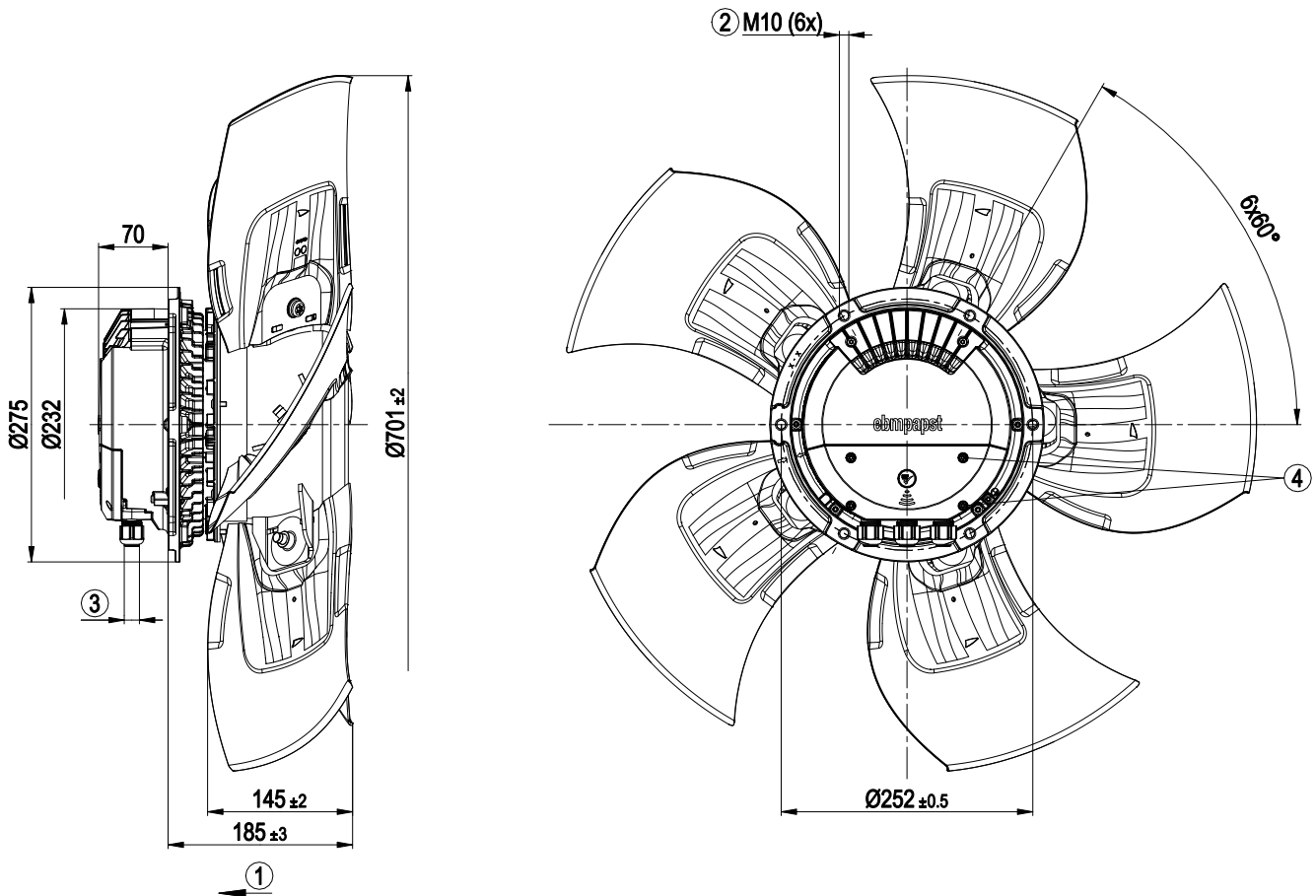

1	Airflow direction "V"
2	Max. clearance for screw 20 mm
3	Cable diameter min. 4 mm, max. 10 mm, tightening torque $4 \pm 0.6$ Nm (The tightening torque is designed for PVC cables. If the cable materials are different, the tightening torque may have to be adjusted)
4	Tightening torque $1.5 \pm 0.2$ Nm

# EC axial fan - HyBlade

sickle-shaped blades (S series)

## Connection diagram

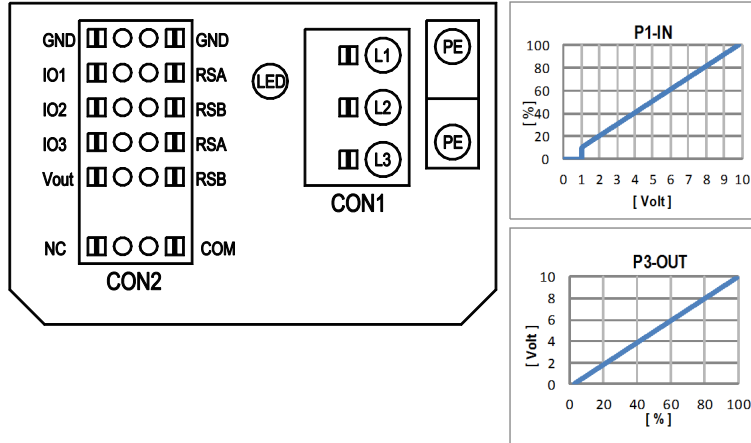

No.	Conn.	Designation	Function/assignment
	CON1	L1, L2, L3	Power supply, phase, see nameplate for voltage range
	PE	PE	Protective earth
	CON2	RSA	RS485 interface for MODBUS, RSA; SELV
	CON2	RSB	RS485 interface for MODBUS, RSB; SELV
	CON2	GND	Reference ground for control interface, SELV
	CON2	IO1	Function parameterizable (see "Optional interface functions" table) Factory setting: Digital input - high active, function: Disable input, SELV - inactive: Pin open or applied voltage < 1.5 VDC - active: applied voltage 3.5-50 VDC Reset function: Triggering of error reset on change of state from "enabled" to "disabled"
	CON2	IO2	Function parameterizable (see "Optional interface functions" table) Factory setting: Analog input 0-10 V / PWM, Ri=100 kΩ, function: Set value Characteristic curve parameterizable (see input characteristic curve P1-IN), SELV
	CON2	IO3	Function parameterizable (see "Optional interface functions" table) Factory setting: Analog output 0-10 V, max. 5 mA, function: Fan modulation level Characteristic curve parameterizable (see output characteristic curve P3-OUT), SELV
	CON2	Vout	Voltage output 3.3-24 VDC ±5%, Pmax=800 mW, voltage parameterizable Factory setting: 10 VDC short-circuit-proof, supply for external devices, SELV alternatively: 15-50 VDC input for parameterization via MODBUS without line voltage
	CON2	COM	Status relay, floating status contact, common connection, contact rating 250 VAC / 2 A (AC1) / min. 10 mA, reinforced insulation on supply side and on control interface side
	CON2	NC	Status relay, floating status contact, break for failure
		LED	green: status = good, ready for operation orange: status = warning red: status = failure
		P1-IN	Input characteristic curve
		P3-OUT	Output characteristic curve



## Terminal/plug assignment

CON2	configurable IO mode	electrical specification	configurable IO functions: normal / inverse	MODBUS Register for IO mode configuration	
				source: set value	switch: fan enable / disable
IO1	○ Din1 (active high), digital input	active: applied voltage 3.5-50VDC, SELV not active: pin open or applied voltage < 1.5VDC		○	D158 [0]
	○ Ain1 0-10V/PWM: analog input	RI = 100k, characteristic curve parameterizable, f <sub>PWM</sub> = 1k..10kHz, SELV		○	D158 [2]
	○ Tach out (open collector output)	U <sub>max</sub> = 50VDC, I <sub>max</sub> = 20mA, SELV		○	D158 [5]
	○ Diagnostics out (open collector output)	U <sub>max</sub> = 50VDC, I <sub>max</sub> = 20mA, SELV		○	D158 [6]
IO2	○ Din2 (active high), digital input	active: applied voltage 3.5-50VDC, SELV not active: pin open or applied voltage < 1.5VDC		○	D159 [0]
	○ Ain2 0-10V/PWM: analog input	RI = 100k, characteristic curve parameterizable, f <sub>PWM</sub> = 1k..10kHz, SELV		○	D159 [2]
	○ Ain2 4-20mA: analog input	RI = 125R, characteristic curve parameterizable, SELV		○	D159 [3]
	○ Din3 (active high), digital input	active: applied voltage 3.5-50VDC, SELV not active: pin open or applied voltage < 1.5VDC		○	D15A [0]
IO3	○ Din3 (active low), digital input	active: applied voltage < 1.5VDC, SELV not active: pin open or applied voltage 3.5-50VDC		○	D15A [1]
	○ PWMIn3: digital input, idle level high	PWM = 40Hz - 10kHz, characteristics parameterizable		○	D15A [7]
	○ PWMIn3: digital input, idle level low	active: pin open or applied voltage 3.5-50VDC not active: applied voltage < 1.5VDC, SELV		○	D15A [8]
	○ Aout3 0-10V: analog output	function parameterizable, max. 5mA, max output frequency 300Hz, SELV		○	D15A [4]
RSA	○ Tacho out (pulses), analog output	0-10V/max. 5mA, max output frequency 300Hz, SELV		○	D15A [5]
	○ Diagnostics out (pulses)	0-10V/max. 5mA, max output frequency 300Hz, SELV		○	D15A [6]
	○ Vout	MODBUS RTU, specification V6.3, SELV		○	
RSB	RS485 bus connection,				
Vout	voltage output	voltage parameterizable 3.3...24VDC +/- 5%, P <sub>max</sub> =600mW, short-circuit-proof, supply for external devices, SELV			D16E [..]
	alternatively: Input auxiliary power supply for parameterization via RS485/MODBUS RTU without line voltage	15...50VDC			

○ configurable option

For further information and additional functions see EC Control Software, Fan-Set-App, or MODBUS Parameter Specification V6.3



## Curves: Air performance 50 Hz

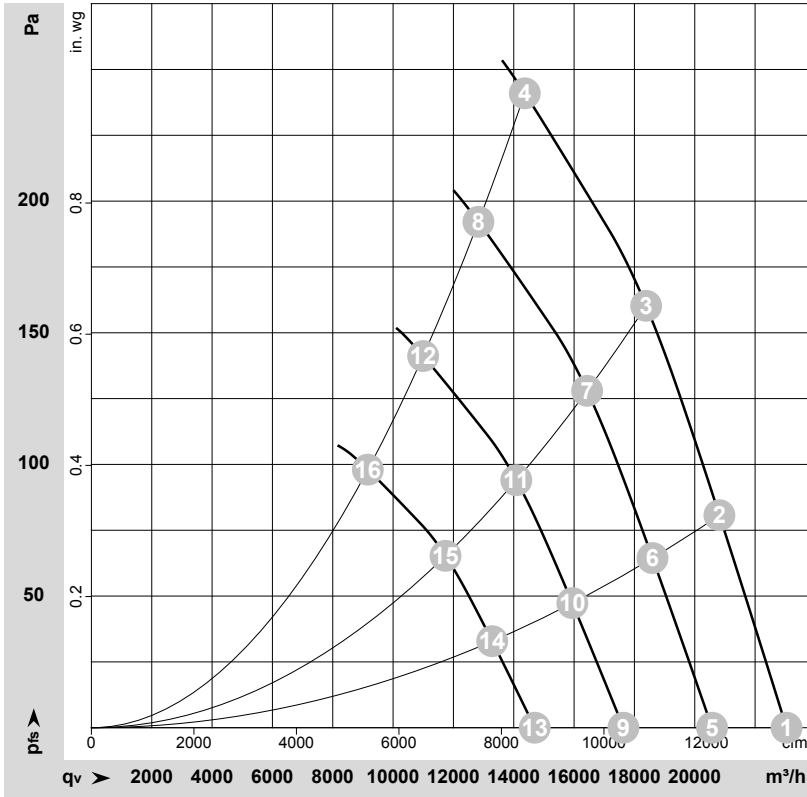

$\rho = 1.15 \text{ kg/m}^3 \pm 2 \%$

Measurement: LU-203012-1

Air performance measured according to ISO 5801 installation category A. For detailed information on the measurement setup, contact ebmpapst. Intake sound level: Sound power level according to ISO 13347 / sound pressure level measured at 1 m distance from fan axis. The values given are valid under the specified measuring conditions and may vary due to conditions of installation. For deviations from the standard configuration, the parameters have to be checked on the installed unit.

## Measured values

	Wired	U	f	n	P <sub>ed</sub>	I	LpA <sub>in</sub>	LwA <sub>in</sub>	LwA <sub>out</sub>	q <sub>v</sub>	p <sub>fs</sub>	q <sub>v</sub>	p <sub>fs</sub>
		V	Hz	min <sup>-1</sup>	W	A	dB(A)	dB(A)	dB(A)	m <sup>3</sup> /h	Pa	cfm	in. wg
1	3~	400	50	1175	1865	2.93	69	76	78	23045	0	13565	0.00
2	3~	400	50	1170	2060	3.22	69	75	77	20815	80	12250	0.32
3	3~	400	50	1170	2241	3.49	70	76	77	18390	160	10825	0.64
4	3~	400	50	1170	2400	3.70	75	82	81	14365	240	8455	0.96
5	3~	400	50	1050	1327	2.09	66	73	75	20575	0	12110	0.00
6	3~	400	50	1050	1470	2.30	66	73	74	18600	66	10950	0.26
7	3~	400	50	1050	1599	2.49	67	73	74	16430	130	9670	0.52
8	3~	400	50	1050	1700	2.64	72	79	78	12830	192	7550	0.77
9	3~	400	50	900	836	1.32	62	69	71	17635	0	10380	0.00
10	3~	400	50	900	926	1.45	62	69	70	15945	48	9385	0.19
11	3~	400	50	900	1007	1.57	63	70	70	14085	96	8290	0.39
12	3~	400	50	900	1071	1.66	68	75	74	10995	141	6470	0.57
13	3~	400	50	750	484	0.76	58	65	66	14695	0	8650	0.00
14	3~	400	50	750	536	0.84	58	64	65	13285	33	7820	0.13
15	3~	400	50	750	583	0.91	59	65	65	11735	67	6910	0.27
16	3~	400	50	750	620	0.96	64	70	69	9165	98	5395	0.39

Wired = Wiring · U = Voltage · f = Frequency · n = Speed (rpm) · P<sub>ed</sub> = Power consumption · I = Current draw · LpA<sub>in</sub> = Sound pressure level intake side · LwA<sub>in</sub> = Sound power level intake side · LwA<sub>out</sub> = Sound power level outlet side · q<sub>v</sub> = Air flow · p<sub>fs</sub> = Pressure increase

