



A3G710-AO85-21 ebmpapst Datasheet
 sales@fansco.com
 www.fansco.com

Nominal data

Type	A3G710-AO85-21	
Motor	M3G112-IA	
Phase		1~
Nominal voltage	VAC	230
Nominal voltage range	VAC	200 .. 277
Frequency	Hz	50/60
Type of data definition		ml
State		prelim.
Speed	min ⁻¹	830
Power input	W	700
Current draw	A	3.1
Max. back pressure	Pa	100
Min. ambient temperature	°C	-25
Max. ambient temperature	°C	60

ml = Max. load · me = Max. efficiency · fa = Running at free air · cs = Customer specs · cu = Customer unit
 Subject to alterations

Data according to ErP directive

		Actual	Request 2013	Request 2015
Installation category	A			
Efficiency category	Static			
Variable speed drive	Yes			
Specific ratio*	1.00			
Overall efficiency η_{es}	%	41.3	28.5	32.5
Efficiency grade N		48.8	36	40
Power input P_{ed}	kW	0.66		
Air flow q_v	m ³ /h	10435		
Pressure increase p_{fs}	Pa	87		
Speed n	min ⁻¹	835		

Data definition with optimum efficiency. LU-120942
 The ErP data is determined using a motor-impeller combination in a standardised measurement configuration.



Technical features

Mass	12 kg
Size	710 mm
Surface of rotor	Coated in black
Material of electronics housing	Die-cast aluminium, coated in black
Material of blades	Aluminium sheet insert, sprayed with PP plastic
Number of blades	5
Blade angle	0°
Direction of air flow	"V"
Direction of rotation	Counter-clockwise, seen on rotor
Type of protection	IP 54
Insulation class	"B"
Humidity class	F4-1
Max. permissible ambient motor temp. (transp./ storage)	+80 °C
Min. permissible ambient motor temp. (transp./storage)	-40 °C
Mounting position	Shaft horizontal or rotor on bottom
Condensate discharge holes	Rotor-side
Operation mode	S1
Motor bearing	Ball bearing
Technical features	<ul style="list-style-type: none"> - Output 10 VDC, max. 10 mA - Alarm relay - Motor current limit - PFC, active - Soft start - Control input 10-0 VDC Control interface with SELV potential safely disconnected from the mains - Over-temperature protected electronics / motor - Line undervoltage / phase failure detection
EMC interference immunity	Acc. to EN 61000-6-2 (industrial environment)
EMC harmonics	Acc. to EN 61000-3-2/3
EMC interference emission	Acc. to EN 61000-6-4 (industrial environment)
Touch current acc. IEC 60990 (measuring network Fig. 4, TN system)	<= 3.5 mA
Motor protection	Thermal overload protector (TOP) wired internally
Cable exit	Variable
Protection class	I (if protective earth is connected by customer)
Product conforming to standard	EN 61800-5-1; CE
Approval	CCC; EAC

Product drawing

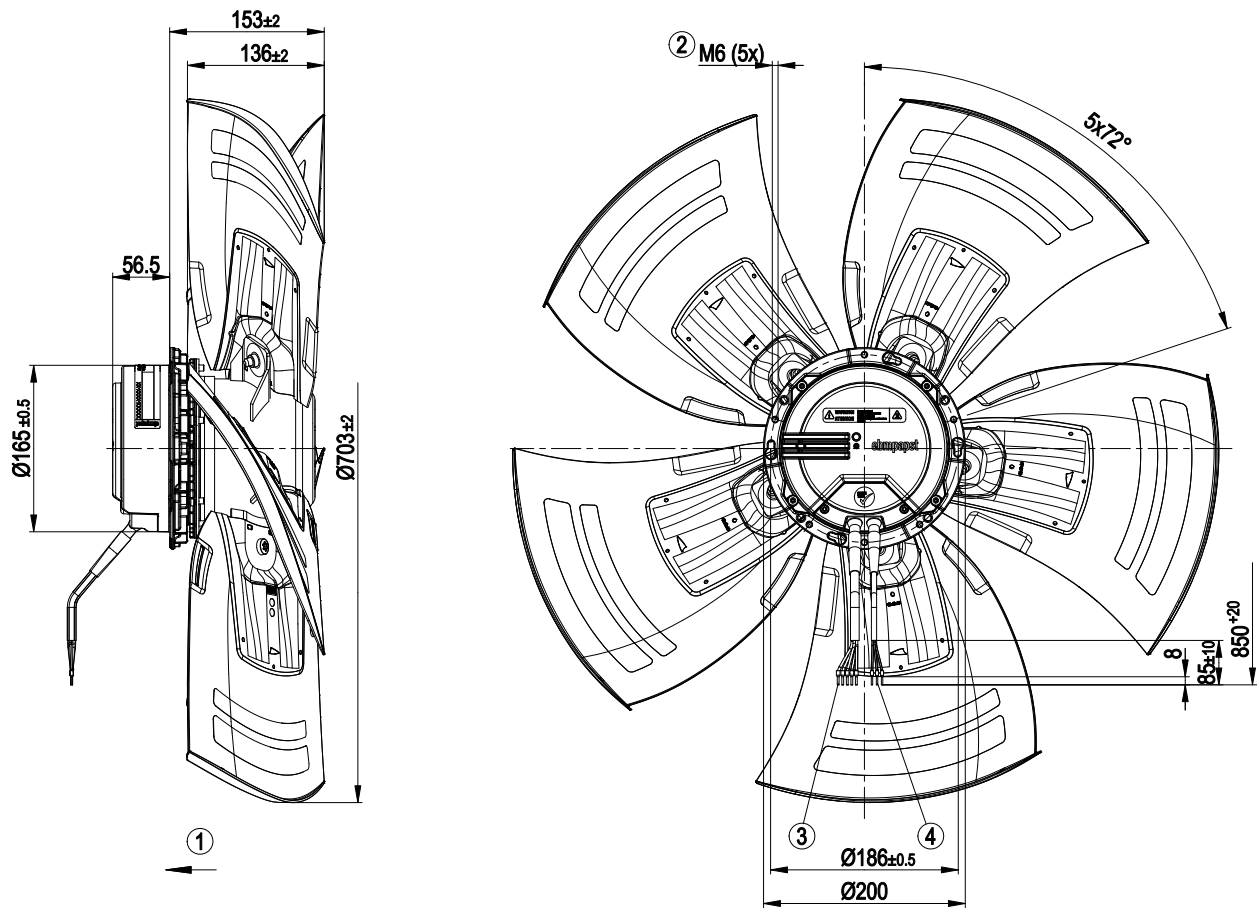

1	Direction of air flow "V"
2	Depth of screw max. 16 mm
3	Connection line PVC AWG18, 5x crimped core-end sleeves
4	Connection line PVC AWG22, 3x crimped core-end sleeves

Connection screen

Customer circuit

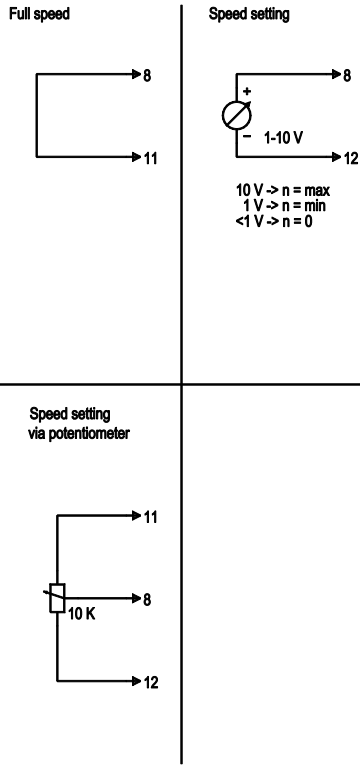

Connection

Fan / motor

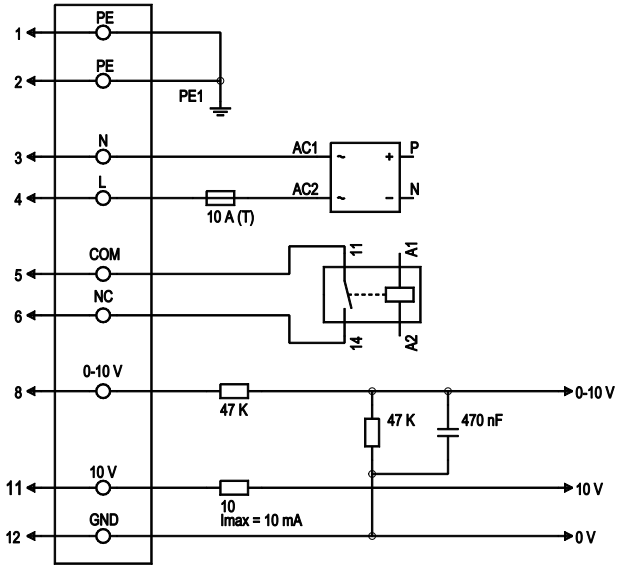

No.	Conn.	Designation	Colour	Function / assignment
1	1,2	PE	green/yellow	Protective earth
1	3	N	blue	Supply voltage, neutral conductor, 50/60 Hz
1	4	L	black	Supply voltage, phase, 50/60 Hz
1	5	COM	white 1	Floating status message contact, break for failure (2 A, max. 250 VAC, min. 10 mA, AC1)
1	6	NC	white 2	Floating status message contact, break for failure
2	8	0-10 V	yellow	Control input, set value 0-10 VDC, impedance 100 kΩ, SELV
2	11	10 VDC	red	Voltage output 10 VDC (+/-3%), max. 10 mA, supply voltage for external devices (e.g. potentiometer), SELV
2	12	GND	blue	Reference mass for control interface, SELV

Charts: Air flow 50 Hz

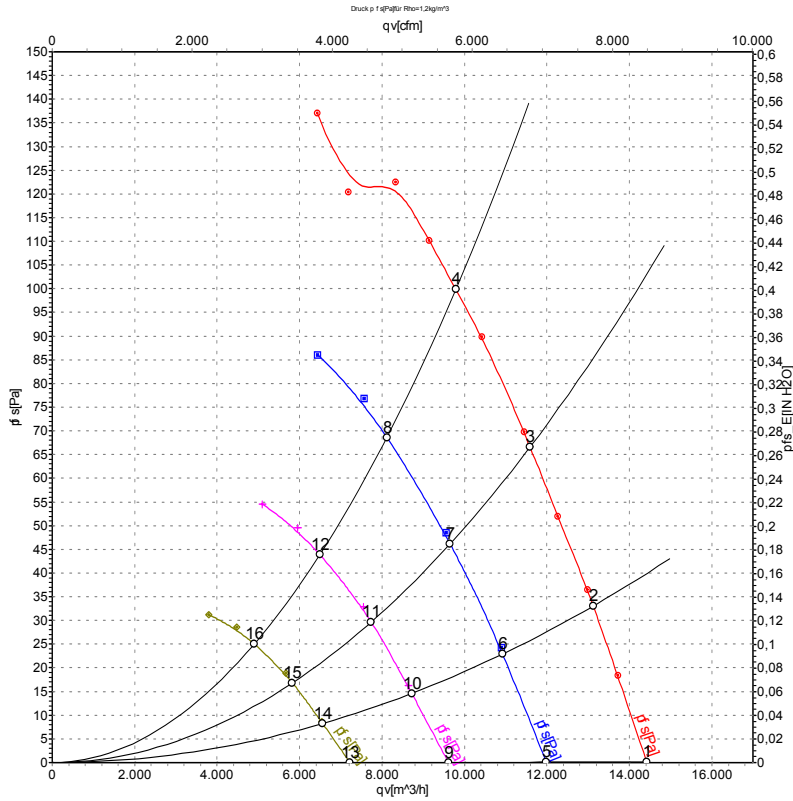

Air performance measured as per ISO 5801 Installation category A. For detailed information on the measuring set-up, please contact ebmpapst. Suction-side noise levels: LwA measured as per ISO 13347 / LpA measured with 1m distance to fan axis. The values given are valid under the measuring conditions mentioned above and may vary according to the actual installation situation. With any deviation from the standard set-up, the specific values have to be checked and reviewed with the unit installed.

Measured values

	U	f	n	P _{ed}	I	LpA _{in}	LwA _{in}	LwA _{out}	qv	p _{fs}
	V	Hz	min ⁻¹	W	A	dB(A)	dB(A)	dB(A)	m ³ /h	Pa
1	230	50	830	448	2.10	62	69	68	14420	0
2	230	50	830	536	2.45	61	67	67	13120	33
3	230	50	830	618	2.78	62	68	68	11590	67
4	230	50	830	700	3.10	66	73	72	9795	100
5	230	50	690	260	1.23	58	64	63	11980	0
6	230	50	690	302	1.41	58	63	63	10920	24
7	230	50	690	352	1.64	58	64	64	9650	47
8	230	50	690	394	1.82	62	68	68	8115	69
9	230	50	550	144	0.68	53	59	58	9610	0
10	230	50	550	170	0.81	53	58	58	8720	15
11	230	50	550	190	0.90	54	60	59	7735	30
12	230	50	550	211	0.99	57	63	63	6490	44
13	230	50	415	74	0.43	48	53	52	7220	0
14	230	50	415	84	0.48	47	52	52	6555	8
15	230	50	415	92	0.51	49	54	54	5825	17
16	230	50	415	100	0.51	51	57	57	4900	25

U = Supply voltage · f = Frequency · n = Speed · P_{ed} = Power input · I = Current draw · LpA_{in} = Sound pressure level inlet side · LwA_{in} = Sound power level inlet side · LwA_{out} = Sound power level outlet side
 qv = Air flow · p_{fs} = Pressure increase

