

A3G630-BG97-08 ebmpapst Datasheet

sales@fansco.com

www.fansco.com

Limited partnership · Headquarters Mulfingen

Amtsgericht (court of registration) Stuttgart · HRA 590344

General partner Elektrobau Mulfingen GmbH · Headquarters Mulfingen

Amtsgericht (court of registration) Stuttgart · HRB 590142

Nominal data

Type	A3G630-BG97-08	
Motor	M3G112-IA	
Phase		3~
Nominal voltage	VAC	400
Nominal voltage range	VAC	380 .. 480
Frequency	Hz	50/60
Method of obtaining data		ml
Speed (rpm)	min ⁻¹	1160
Power consumption	W	1080
Current draw	A	1.7
Max. back pressure	Pa	190
Max. back pressure	in. wg	0.76
Min. ambient temperature	°C	-40
Max. ambient temperature	°C	40

ml = Max. load · me = Max. efficiency · fa = Free air · cs = Customer specification · ce = Customer equipment
Subject to change

Data according to Commission Regulation (EU) 327/2011

		Actual	Req. 2015			
01 Overall efficiency η_{es}	%	50.6	33.6	09 Power consumption P_{ed}	kW	0.97
02 Measurement category		A		09 Air flow q_v	m ³ /h	9445
03 Efficiency category		Static		09 Pressure increase p_{fs}	Pa	173
04 Efficiency grade N		57	40	10 Speed (rpm) n	min ⁻¹	1165
05 Variable speed drive		Yes		11 Specific ratio*		1.00

Data obtained at optimum efficiency level.

The ErP data is determined using a motor-impeller combination in a standardized measurement setup.

* Specific ratio = $1 + p_s / 100\,000\text{ Pa}$

LU-182932



Technical description

Weight	11.2 kg
Fan size	630 mm
Rotor surface	Painted black
Terminal box material	PP plastic
Electronics housing material	Die-cast aluminum, painted black
Blade material	Press-fitted sheet steel blank, sprayed with PP plastic
Number of blades	5
Airflow direction	"A"
Direction of rotation	Clockwise, viewed toward rotor
Degree of protection	IP55
Insulation class	"F"
Moisture (F) / Environmental (H) protection class	H2
Max. permitted ambient temp. for motor (transport/storage)	+70 °C
Min. permitted ambient temp. for motor (transport/storage)	-40 °C
Installation position	Shaft horizontal or rotor on bottom; rotor on top on request
Condensation drainage holes	On rotor side
Mode	S1
Motor bearing	Ball bearing with low-temperature lubricant; (sealed)
Technical features	<ul style="list-style-type: none"> - Output 10 VDC, max. 10 mA - Operation and alarm display - External 24 V input (parameter setting) - Alarm relay - Integrated PID controller - Motor current limitation - PFC, passive - RS-485 MODBUS-RTU - Soft start - EEPROM write cycles: 100,000 maximum - Control input 0-10 VDC / PWM - Control interface with SELV potential safely disconnected from the mains - Thermal overload protection for electronics/motor - Line undervoltage / phase failure detection
EMC immunity to interference	According to EN 61000-6-2 (industrial environment)
EMC interference emission	According to EN 61000-6-3 (household environment), except EN 61000-3-2 for professionally used equipment with a total rated power greater than 1 kW
Touch current according to IEC 60990 (measuring circuit Fig. 4, TN system)	<= 3.5 mA
Electrical hookup	Via terminal box
Motor protection	Thermal overload protector (TOP) internally connected
Protection class	I (with customer connection of protective earth)
Conformity with standards	EN 61800-5-1; CE
Approval	UL 1004-7 + 60730; C22.2 No.77 + CAN/CSA-E60730-1; EAC
Comment	Conformity with EN 60335-1 in preparation

EC axial fan - HyBlade

sickle-shaped blades (S series)

Product drawing

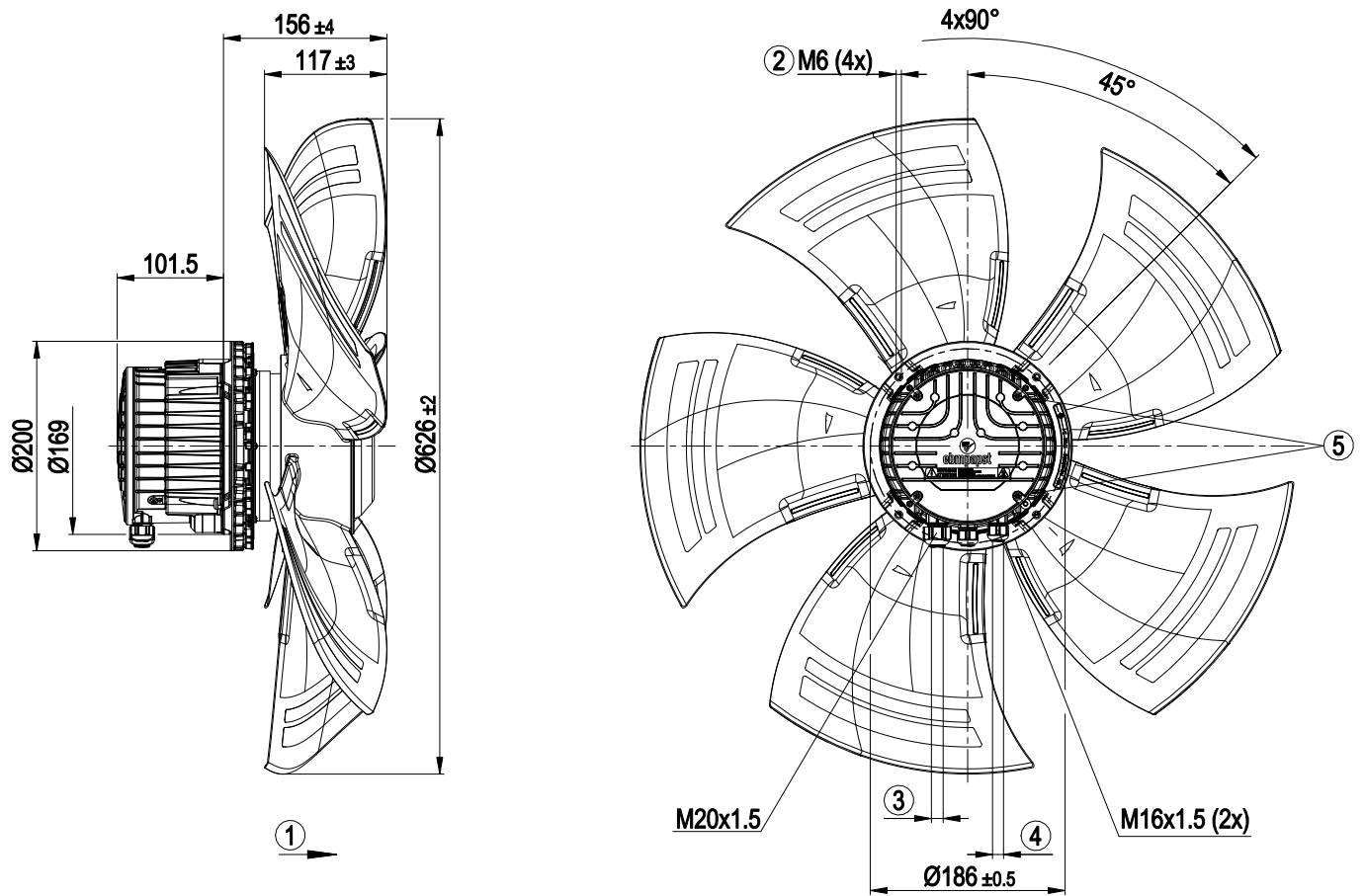

1	Direction of air flow "A"
2	Max. clearance for screw 16 mm
3	Cable diameter min. 8 mm, max. 12 mm, tightening torque 2.5 ± 0.4 Nm
4	Cable diameter min. 6 mm, max. 10 mm, tightening torque 2.5 ± 0.4 Nm Cable diameter min. 4 mm, max. 7 mm, tightening torque 2.5 ± 0.4 Nm (included seal must be used)
5	Tightening torque 1.5 ± 0.2 Nm



EC axial fan - HyBlade

sickle-shaped blades (S series)

Connection diagram

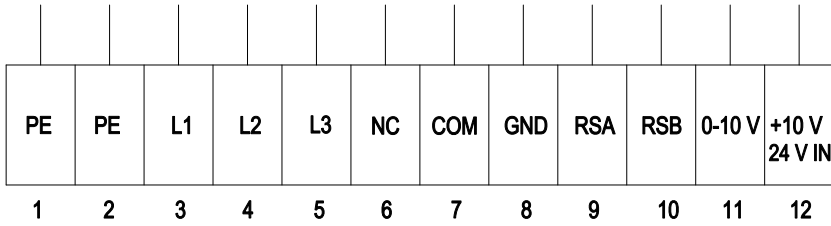

No.	Conn.	Designation	Function/assignment
1	PE	PE	Protective earth
2	PE	PE	Protective earth
3	L1	L1	Power supply
4	L2	L2	Power supply
5	L3	L3	Power supply
6	NC	NC	Status relay, floating status contact, break for failure, contact rating 250 VAC / 2 A (AC1) / min. 10 mA; reinforced insulation on supply side and basic insulation on control interface side
7	COM	COM	Status relay, floating status contact, break for failure, contact rating 250 VAC / 2 A (AC1) / min. 10 mA; reinforced insulation on supply side and basic insulation on control interface side
8	GND	GND	Reference ground for control interface, SELV
9	RSA	RSA	RS485 interface for MODBUS, RSA; SELV
10	RSB	RSB	RS485 interface for MODBUS, RSB; SELV
11	0-10 V	0-10 V	Analog input (set value) SELV, 0-10 V, Ri = 100 kΩ, adjustable curve
12	+10 V	+10 V	Fixed voltage output 10 VDC, SELV, +10 V ±3%, max. 10 mA, short-circuit-proof, power supply for external devices (e.g. pot); fixed voltage input 24 VDC for setting parameters via MODBUS without line voltage supply



Curves: Air performance 50 Hz

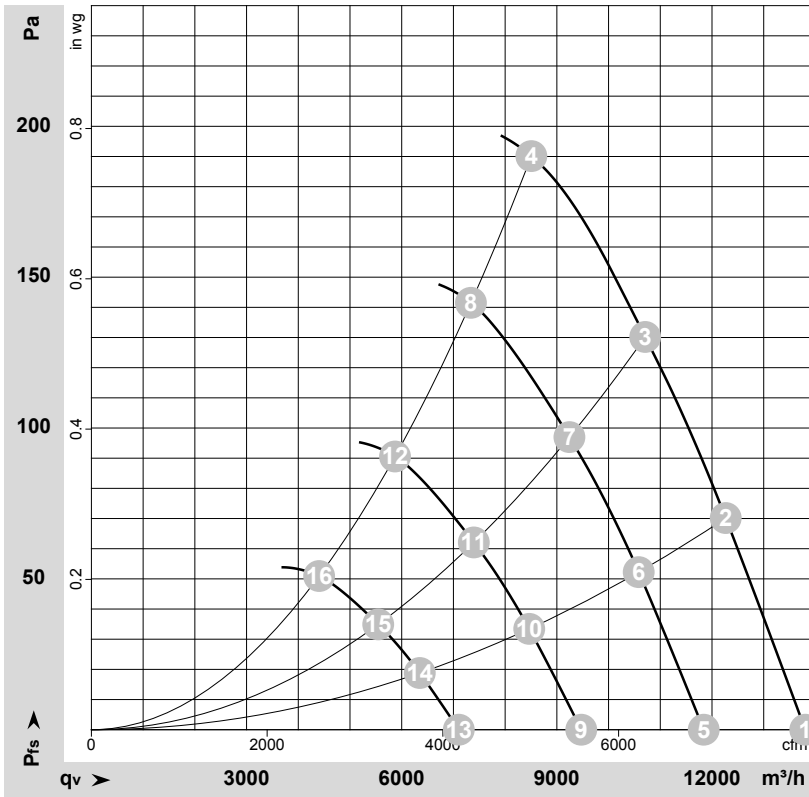

$\rho = 1.15 \text{ kg/m}^3 \pm 2 \%$

Measurement: LU-182932-1

Air performance measured according to ISO 5801 installation category A. For detailed information on the measurement setup, contact ebmpapst. Intake sound level: Sound power level according to ISO 13347 / sound pressure level measured at 1 m distance from fan axis. The values given are valid under the specified measuring conditions and may vary due to conditions of installation. For deviations from the standard configuration, the parameters have to be checked on the installed unit.

Measured values

	U	f	n	P _{ed}	I	LpA _{in}	LwA _{in}	LwA _{out}	q _v	P _{fs}	q _v	P _{fs}
	V	Hz	min ⁻¹	W	A	dB(A)	dB(A)	dB(A)	m ³ /h	Pa	cfm	in. wg
1	400	50	1160	674	1.06	70	77	77	13805	0	8125	0.00
2	400	50	1160	790	1.23	66	72	72	12265	70	7220	0.28
3	400	50	1160	883	1.37	64	71	71	10710	130	6300	0.52
4	400	50	1160	1080	1.70	67	75	74	8505	190	5005	0.76
5	400	50	1000	426	0.67	66	73	73	11840	0	6970	0.00
6	400	50	1000	508	0.79	62	69	69	10585	53	6230	0.21
7	400	50	1000	569	0.88	61	67	67	9245	97	5440	0.39
8	400	50	1000	647	1.00	64	71	70	7340	143	4320	0.57
9	400	50	800	218	0.34	61	67	67	9470	0	5575	0.00
10	400	50	800	260	0.40	56	63	63	8465	34	4985	0.14
11	400	50	800	291	0.45	55	62	61	7395	62	4350	0.25
12	400	50	800	331	0.51	58	65	65	5870	91	3455	0.37
13	400	50	600	92	0.14	53	60	60	7105	0	4180	0.00
14	400	50	600	110	0.17	49	56	56	6350	19	3735	0.08
15	400	50	600	123	0.19	48	55	54	5545	35	3265	0.14
16	400	50	600	140	0.22	51	58	58	4405	51	2590	0.20

U = Power supply · f = Frequency · n = Speed (rpm) · P_{ed} = Power consumption · I = Current draw · LpA_{in} = Sound pressure level intake side · LwA_{in} = Sound power level intake side
 LwA_{out} = Sound power level outlet side · q_v = Air flow · P_{fs} = Pressure increase

