

A3G630-AU31-03 ebmpapst Datasheet

sales@fansco.com

www.fansco.com

Limited partnership · Headquarters Mulfingen

Amtsgericht (court of registration) Stuttgart · HRA 590344

General partner Elektrobau Mulfingen GmbH · Headquarters Mulfingen

Amtsgericht (court of registration) Stuttgart · HRB 590142

Nominal data

Type	A3G630-AU31-03	
Motor	M3G150-IF	
Phase		3~
Nominal voltage	VAC	400
Nominal voltage range	VAC	380 .. 480
Frequency	Hz	50/60
Method of obtaining data		ml
Speed (rpm)	min ⁻¹	1580
Power consumption	W	3700
Current draw	A	5.6
Max. back pressure	Pa	340
Max. back pressure	in. wg	1.36
Min. ambient temperature	°C	-40
Max. ambient temperature	°C	60

ml = Max. load · me = Max. efficiency · fa = Free air · cs = Customer specification · ce = Customer equipment
Subject to change

Data according to Commission Regulation (EU) 327/2011 (EN 17166)

		Actual	Req. 2015		
01 Overall efficiency η_{es}	%	40.3	37.3	09 Power consumption P_{ed}	kW 3.66
02 Measurement category		A		09 Air flow q_v	m ³ /h 15490
03 Efficiency category		Static		09 Pressure increase p_{fs}	Pa 329
04 Efficiency grade N		43.1	40	10 Speed (rpm) n	min ⁻¹ 1585
05 Variable speed drive		Yes		11 Specific ratio*	1.00

Data obtained at optimum efficiency level.

The ErP data is determined using a motor-impeller combination in a standardized measurement setup.

* Specific ratio = $1 + p_s / 100\,000\text{ Pa}$

LU-202449



Technical description

Weight	23.54 kg
Size	630 mm
Motor size	150
Rotor surface	Painted black
Electronics housing material	Die-cast aluminum, painted gray
Blade material	Sheet aluminum insert, sprayed with PP plastic
Number of blades	5
Blade pitch	0°
Airflow direction	V
Direction of rotation	Clockwise, viewed toward rotor
Degree of protection	IP55
Insulation class	"F"
Moisture (F) / Environmental (H) protection class	H2
Ambient temperature note	Occasional start-up at temperatures between -40°C and -25°C is permitted. For continuous operation at ambient temperatures below -25°C (such as refrigeration applications), use must be made of a fan design with special low-temperature bearings.
Max. permitted ambient temp. for motor (transport/storage)	+80 °C
Min. permitted ambient temp. for motor (transport/storage)	-40 °C
Installation position	Shaft horizontal or rotor on bottom; rotor on top on request
Condensation drainage holes	On rotor side
Mode	S1
Motor bearing	Ball bearing
Technical features	<ul style="list-style-type: none"> - Operation and alarm display with LED - External 15-50 VDC input (parameterization) - Alarm relay - Integrated PI controller - Configurable inputs/outputs (I/O) - MODBUS V6.0 - Motor current limitation - RFID - ISO 15693 compatible - RS-485 MODBUS-RTU - Soft start - Voltage output 3.3-24 VDC, Pmax = 800 mW - Control interface with SELV potential safely disconnected from the mains - Thermal overload protection for electronics/motor - Line undervoltage / phase failure detection
EMC immunity to interference	According to EN 61000-6-2 (industrial environment)
EMC interference emission	According to EN 61000-6-3 (household environment), except EN 61000-3-2 for professionally used equipment with a total rated power greater than 1 kW
Touch current according to IEC 60990 (measuring circuit Fig. 4, TN system)	<= 3.5 mA
Electrical hookup	Terminal box
Motor protection	Reverse polarity and locked-rotor protection
Protection class	I (with customer connection of protective earth)
Conformity with standards	EN 61800-5-1; CE

A3G630-AU31-03

EC axial fan - HyBlade

sickle-shaped blades (S series)

Approval

CSA C22.2 No. 77 + CAN/CSA-E60730-1; EAC; UL 1004-7 + 60730-1



Product drawing

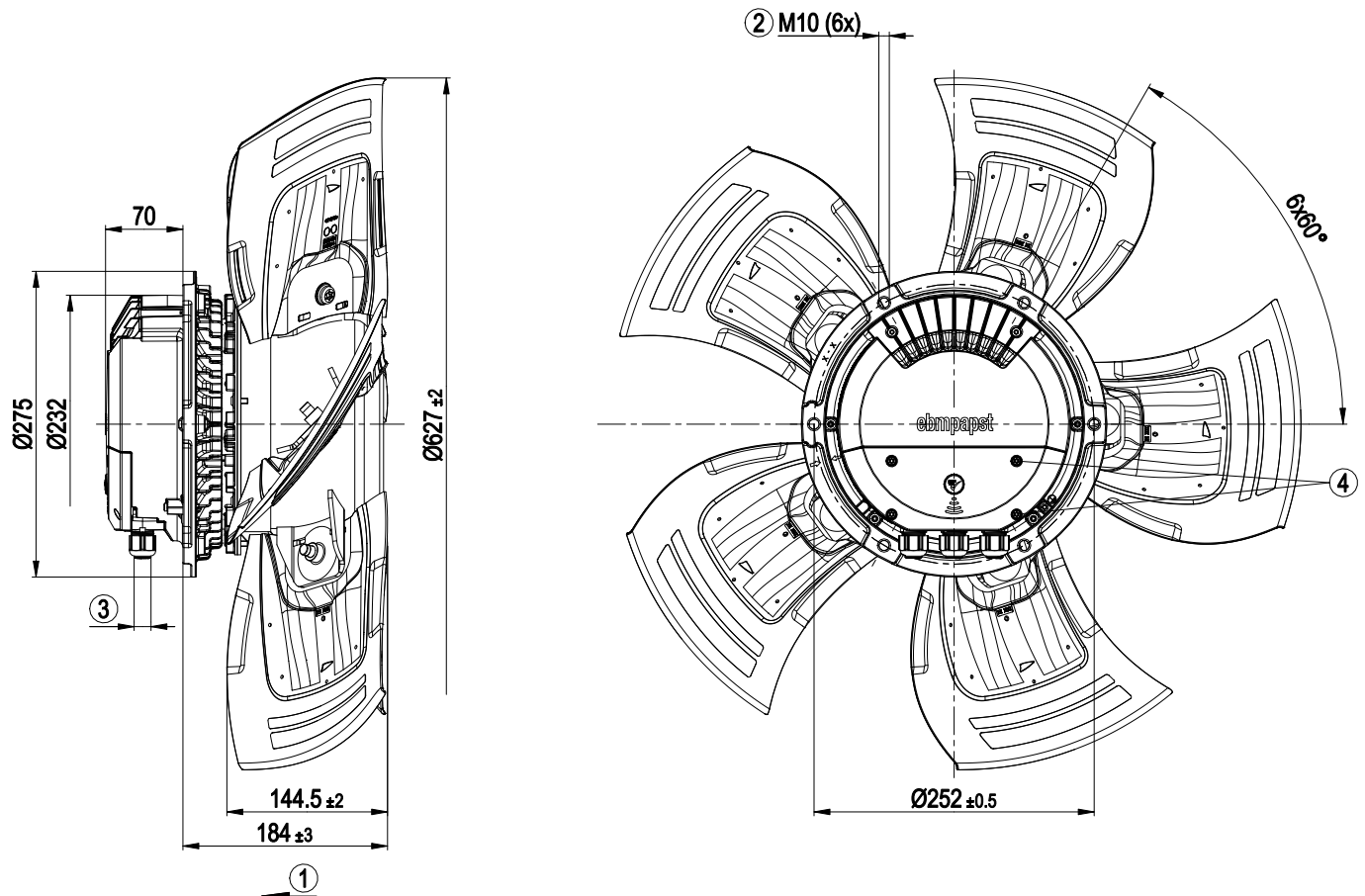

1	Airflow direction "V"
2	Max. clearance for screw 20 mm
3	Cable diameter min. 4 mm, max. 10 mm, tightening torque 4 ± 0.6 Nm
4	Tightening torque 1.5 ± 0.2 Nm

EC axial fan - HyBlade

sickle-shaped blades (S series)

Connection diagram

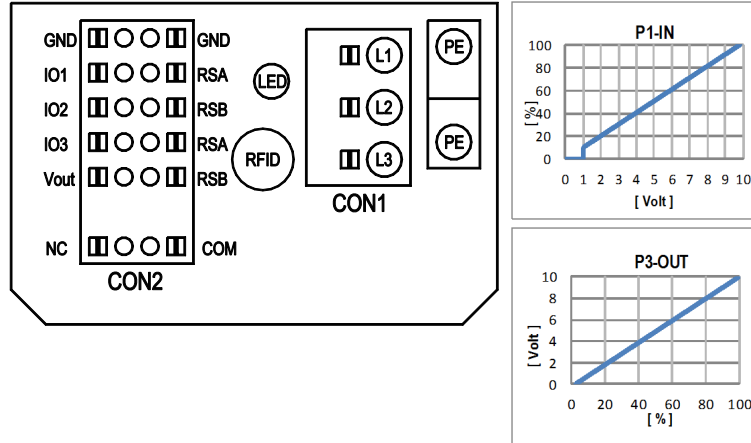

No.	Conn.	Designation	Function/assignment
	CON1	L1, L2, L3	Power supply, phase, see nameplate for voltage range
	PE	PE	Protective earth
	CON2	RSA	RS485 interface for MODBUS, RSA; SELV
	CON2	RSB	RS485 interface for MODBUS, RSB; SELV
	CON2	GND	Reference ground for control interface, SELV
	CON2	IO1	Function parameterizable (see "Optional interface functions" table) Factory setting: Digital input - high active, function: Disable input, SELV - inactive: Pin open or applied voltage < 1.5 VDC - active: applied voltage 3.5-50 VDC Reset function: Triggering of error reset on change of state from "enabled" to "disabled"
	CON2	IO2	Function parameterizable (see "Optional interface functions" table) Factory setting: Analog input 0-10 V / PWM, Ri=100 kΩ, function: Set value Characteristic curve parameterizable (see input characteristic curve P1-IN), SELV
	CON2	IO3	Function parameterizable (see "Optional interface functions" table) Factory setting: Analog output 0-10 V, max. 5 mA, function: Fan modulation level Characteristic curve parameterizable (see output characteristic curve P3-OUT), SELV
	CON2	Vout	Voltage output 3.3-24 VDC ±5%, Pmax=800 mW, voltage parameterizable Factory setting: 10 VDC short-circuit-proof, supply for external devices, SELV alternatively: 15-50 VDC input for parameterization via MODBUS without line voltage
	CON2	COM	Status relay, floating status contact, common connection, contact rating 250 VAC / 2 A (AC1) / min. 10 mA, reinforced insulation on supply side and on control interface side
	CON2	NC	Status relay, floating status contact, break for failure
		LED	green: status = good, ready for operation orange: status = warning red: status = failure
		P1-IN	Input characteristic curve
		P3-OUT	Output characteristic curve



Terminal/plug assignment

CON2	configurable IO mode	electrical specification	configurable IO functions: normal / inverse	INPUT		OUTPUT												
				source: set value	source: sensor value	switch: parameter set: #1 / #2	switch: control function: heating (pos.), cooling (neg.)	switch: direction of rotation: cw / ccw	switch: set value source	switch: fan enable / disable	signal: tach out	signal: diagnostics out (selected directly via IO mode)	signal: fan modulation level %	signal: actual speed	signal: system modulation level %	signal: remote control output 0-10V	pulse input for auto-addressing	pulse output for auto-addressing
101	○ Din1 (active high), digital input	not active: pin open or applied voltage < 1.5VDC active: applied voltage 3.5-50VDC, SELV	D158 [0]	○	○	○	○	○	○	○	○	○	○	○	○	○	○	○
	○ Ain1 0-10V/PWM: analog input	Ri=100k, characteristic curve parameterizable, f _{PWM} =1k..10kHz, SELV	D158 [2]	○	○	○	○	○	○	○	○	○	○	○	○	○	○	○
	○ Tacho out (open collector output)	U _{max} =50VDC, I _{max} =20mA, SELV	D158 [5]	○	○	○	○	○	○	○	○	○	○	○	○	○	○	○
	○ Diagnostics out (open collector output)	U _{max} =50VDC, I _{max} =20mA, SELV	D158 [6]	○	○	○	○	○	○	○	○	○	○	○	○	○	○	○
102	○ Din2 (active high), digital input	not active: pin open or applied voltage < 1.5VDC active: applied voltage 3.5-50VDC, SELV	D159 [0]	○	○	○	○	○	○	○	○	○	○	○	○	○	○	○
	○ Ain2 0-10V/PWM: analog input	Ri=100k, characteristic curve parameterizable, f _{PWM} =1k..10kHz, SELV	D159 [2]	○	○	○	○	○	○	○	○	○	○	○	○	○	○	○
	○ Ain2 4-20mA: analog input	Ri=125R, characteristic curve parameterizable, SELV	D159 [3]	○	○	○	○	○	○	○	○	○	○	○	○	○	○	○
103	○ Din3 (active high), digital input	not active: pin open or applied voltage < 1.5VDC active: applied voltage 3.5-50VDC, SELV	D15A [0]	○	○	○	○	○	○	○	○	○	○	○	○	○	○	○
	○ Din3 (active low), digital input	not active: pin open or applied voltage < 1.5VDC active: applied voltage 3.5-50VDC, SELV	D15A [1]	○	○	○	○	○	○	○	○	○	○	○	○	○	○	○
	○ PWMIn3: digital input	40Hz - 10kHz, characteristics parameterizable	D15A [7]	○	○	○	○	○	○	○	○	○	○	○	○	○	○	○
	○ Aout3 0-10V: analog output	not active: pin open or applied voltage < 1.5VDC, SELV active: applied voltage < 1.5VDC, SELV	D15A [4]	○	○	○	○	○	○	○	○	○	○	○	○	○	○	○
RSA RSB	○ Tacho out (pulses), analog output	function parameterizable, max. 5mA, max output frequency 300Hz, SELV	D15A [5]	○	○	○	○	○	○	○	○	○	○	○	○	○	○	○
	○ Diagnostics out (pulses)	0-10V max. 5mA, max output frequency 300Hz, SELV	D15A [6]	○	○	○	○	○	○	○	○	○	○	○	○	○	○	○
	RS485 bus connection,	MODBUS RTU, specification V6.0, SELV		○	○	○	○	○	○	○	○	○	○	○	○	○	○	○
Vout	voltage output	voltage parameterizable 3.3...24VDC +/- 5.5%, P _{max} =800mW, short-circuit-proof, supply for external devices, SELV	D16E [..]	○	○	○	○	○	○	○	○	○	○	○	○	○	○	○
	alternatively: input auxiliary power supply for parameterization via RS485/MODBUS RTU without line voltage	15...50VDC		○	○	○	○	○	○	○	○	○	○	○	○	○	○	○

○ configurable option

For further information and additional functions see EC Control Software, Fan-Set-App, or MODBUS Parameter Specification V6.0



Curves: Air performance 50 Hz

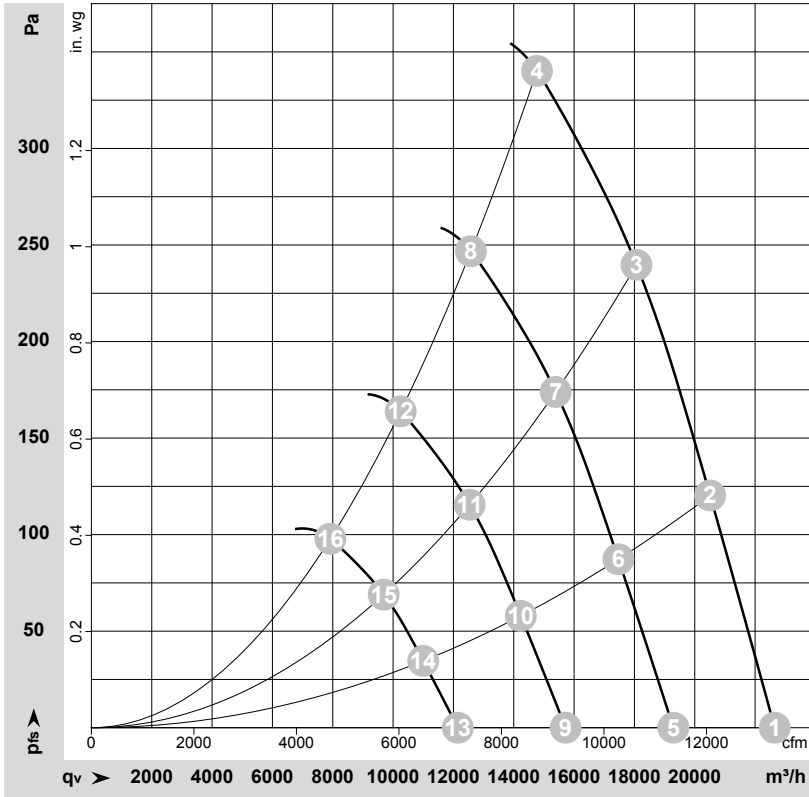

$\rho = 1.15 \text{ kg/m}^3 \pm 2 \%$

Measurement: LU-202449-1

Air performance measured according to ISO 5801 installation category A. For detailed information on the measurement setup, contact ebmpapst. Intake sound level: Sound power level according to ISO 13347 / sound pressure level measured at 1 m distance from fan axis. The values given are valid under the specified measuring conditions and may vary due to conditions of installation. For deviations from the standard configuration, the parameters have to be checked on the installed unit.

Measured values

	Wired	U	f	n	P _{ed}	I	LpA _{in}	LwA _{in}	LwA _{out}	q _v	p _{fs}	q _v	p _{fs}
		V	Hz	min ⁻¹	W	A	dB(A)	dB(A)	dB(A)	m ³ /h	Pa	cfm	in. wg
1	3~	400	50	1580	2960	4.55	75	82	84	22650	0	13330	0.00
2	3~	400	50	1580	3237	4.96	75	82	83	20510	120	12070	0.48
3	3~	400	50	1580	3501	5.36	76	82	82	18070	240	10635	0.96
4	3~	400	50	1580	3700	5.60	80	86	85	14770	340	8695	1.36
5	3~	400	50	1350	1829	2.81	71	78	80	19290	0	11355	0.00
6	3~	400	50	1350	2000	3.07	71	78	79	17470	89	10280	0.36
7	3~	400	50	1350	2163	3.31	72	78	78	15390	176	9060	0.71
8	3~	400	50	1350	2279	3.48	75	82	81	12580	247	7405	0.99
9	3~	400	50	1100	990	1.52	66	73	74	15720	0	9250	0.00
10	3~	400	50	1100	1082	1.66	66	72	73	14235	59	8375	0.24
11	3~	400	50	1100	1170	1.79	67	73	73	12540	117	7380	0.47
12	3~	400	50	1100	1233	1.88	70	77	76	10250	164	6035	0.66
13	3~	400	50	850	457	0.70	60	66	68	12145	0	7150	0.00
14	3~	400	50	850	499	0.77	59	66	67	11000	35	6475	0.14
15	3~	400	50	850	540	0.83	60	66	67	9690	70	5705	0.28
16	3~	400	50	850	569	0.87	64	70	70	7920	98	4660	0.39

Wired = Wiring · U = Voltage · f = Frequency · n = Speed (rpm) · P_{ed} = Power consumption · I = Current draw · LpA_{in} = Sound pressure level intake side · LwA_{in} = Sound power level intake side · LwA_{out} = Sound power level outlet side · q_v = Air flow · p_{fs} = Pressure increase

