



A3G630-AS21-01 ebmpapst Datasheet

sales@fansco.com

www.fansco.com

## Nominal data

Type	A3G630-AS21-01	
Motor	M3G150-FF	
Phase		3~
Nominal voltage	VAC	400
Nominal voltage range	VAC	380 .. 480
Frequency	Hz	50/60
Type of data definition		ml
Speed	min <sup>-1</sup>	1230
Power input	W	1850
Current draw	A	2.85
Max. back pressure	Pa	190
Min. ambient temperature	°C	-25
Max. ambient temperature	°C	+70

ml = max. load · me = max. efficiency · fa = running at free air · cs = customer specs · cu = customer unit  
Subject to alterations

## Data according to ErP directive

Installation category	A
Efficiency category	Static
Variable speed drive	Yes
Specific ratio*	1,00

\* Specific ratio =  $1 + p_b / 100\,000\text{ Pa}$

	Actual	Request 2013	Request 2015
Overall efficiency $\eta_{es}$	36,5	31,3	35,3
Efficiency grade N	41,2	36	40
Power input $P_{ed}$	kW	1,82	
Air flow $q_v$	m <sup>3</sup> /h	10715	
Pressure increase $p_{fs}$	Pa	209	
Speed n	min <sup>-1</sup>	1235	

Data established at point of optimum efficiency



## Technical features

Mass	21.2 kg
Size	630 mm
Surface of rotor	Coated in black
Material of electronics housing	Die-cast aluminium, coated in black
Material of blades	Aluminium sheet insert, sprayed with PP plastic
Number of blades	5
Blade angle	0°
Direction of air flow	"V"
Direction of rotation	Clockwise, seen on rotor
Type of protection	IP 54
Insulation class	"F"
Humidity class	F4-1
Max. permissible ambient motor temp. (transp./ storage)	+80 °C
Min. permissible ambient motor temp. (transp./storage)	-40 °C
Mounting position	Shaft horizontal or rotor on bottom; rotor on top on request
Condensate discharge holes	Rotor-side
Operation mode	S1
Motor bearing	Ball bearing
Technical features	<ul style="list-style-type: none"> <li>- Output 10 VDC, max. 10 mA</li> <li>- Output 20 VDC, max. 50 mA</li> <li>- Output for slave 0-10 V</li> <li>- Input for sensor 0-10 V or 4-20 mA</li> <li>- External 24 V input (programming)</li> <li>- External release input</li> <li>- Alarm relay</li> <li>- Integrated PID controller</li> <li>- Motor current limit</li> <li>- PFC, passive</li> <li>- RS485 MODBUS RTU</li> <li>- Soft start</li> <li>- Control input 0-10 VDC / PWM</li> <li>- Control interface with SELV potential safely disconnected from the mains</li> <li>- Over-temperature protected electronics / motor</li> <li>- Line undervoltage / phase failure detection</li> </ul>
EMC interference immunity	Acc. to EN 61000-6-2 (industrial environment)
EMC interference emission	Acc. to EN 55022 (Class B, household environment)
Leakage current	<= 3.5 mA
Electrical leads	Via terminal box
Motor protection	Reverse polarity and locked-rotor protection
Protection class	I (if protective earth is connected by customer)
Product conforming to standard	EN 61800-5-1; CE
Approval	C22.2 Nr.77 + CAN/CSA-E60730-1; UL 1004-7 + 60730

Product drawing

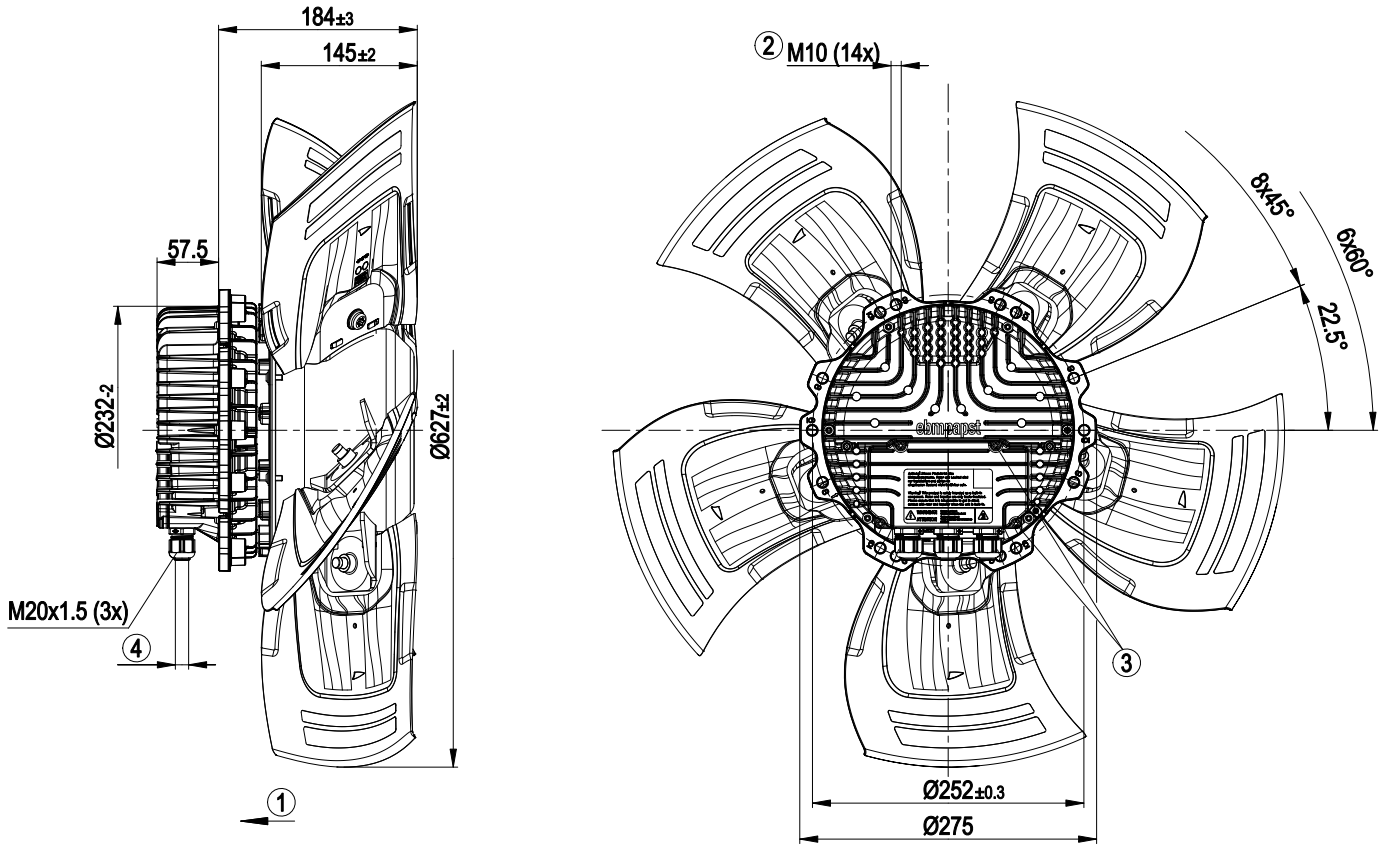

1	Direction of air flow "V"
2	Depth of screw max. 25 mm
3	Tightening torque 3.5±0.5 Nm
4	Cable diameter: min. 4 mm, max. 10 mm, tightening torque: 4±0.6 Nm

## Connection screen

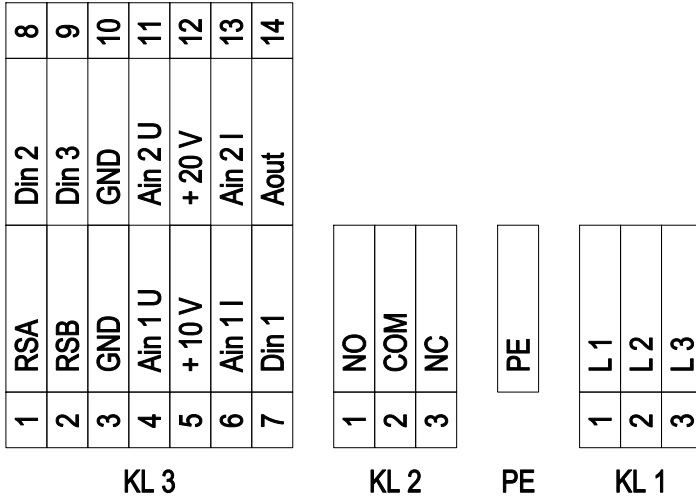

No.	Pin	Signal	Function / assignment
KL 1	1	L1	Mains supply connection, supply voltage 3~380-480 VAC; 50/60 Hz
KL 1	2	L2	Mains supply connection, supply voltage 3~380-480 VAC; 50/60 Hz
KL 1	3	L3	Mains supply connection, supply voltage 3~380-480 VAC; 50/60 Hz
PE		PE	Earth connection, PE connection
KL 2	1	NO	Status relay, floating status contact; normally open; close with error
KL2	2	COM	Status relay; floating status contact; changeover contact; common connection; contact rating 250 VAC / 2 A (AC1)
KL2	3	NC	Status relay, floating status contact; break with error
KL 3	1	RSA	Bus connection RS485; RSA; MODBUS RTU
KL 3	2	RSB	Bus connection RS485; RSB; MODBUS RTU
KL 3	3 / 10	GND	Signal ground for control interface KL3
KL 3	4	Ain1 U	Analogue input 1 (set value); 0-10 V; Ri= 100 kΩ; parametrisable curves; only usable as alternative to input Ain1 I
KL 3	5	+ 10 V	Fixed voltage output 10 VDC; + 10 V +/-3%; max. 10 mA; short circuit proof; power supply for ext. devices (e.g. potentiometer)
KL 3	6	Ain1 I	Analogue input 1 (set value); 4-20 mA; Ri= 100 Ω; parametrisable curves; only usable as alternative to input Ain1 U
KL 3	7	Din1	Digital input 1: enabling of electronics; enabling: open pin or applied voltage 5 to 50 VDC; disabling: bridge to GND or applied voltage < 1 VDC; reset function: triggers software reset after a level change to <1 V
KL 3	8	Din2	Digital input 2: parameter set switch 1/2; according to EEPROM setting, the valid/used parameter set is selectable per BUS or per digital input DIN2. Parameter set 1: open pin or applied voltage 5 to 50 VDC; parameter set 2: bridge to GND or applied voltage < 1 VDC
KL 3	9	Din3	Digital input 3: Control characteristic of the integrated controller; according to EEPROM setting, the control characteristic of the integrated controller is normally/inversely selectable per BUS or per digital input; normal: open pin or applied voltage 5 to 50 VDC (control deviation = actual sensor value - set value) inverse: bridge to GND or applied voltage < 1 VDC (control deviation = set value - actual sensor value)
KL 3	11	Ain2 U	Analogue input 2; actual sensor value 0-10 V; Ri= 100 kΩ; parametrisable curve; only usable as alternative to input Ain2 I
KL 3	12	+ 20 V	Fixed voltage output 20 VDC; + 20 V +/-25/-10 %; max. 50 mA; short circuit proof; power supply for ext. devices (e.g. sensors)
KL 3	13	Ain2 I	Analogue input 2; actual sensor value 4-20 mA; Ri= 100 Ω; parametrisable curve; only usable as alternative to input Ain2 U
KL 3	14	Aout	Analogue output 0-10 V; max. 5 mA; output of the actual motor control factor (output voltage of electronics)/ of the actual motor speed; function selectable per bus; parametrisable curve.



## Charts: Air flow 50 Hz

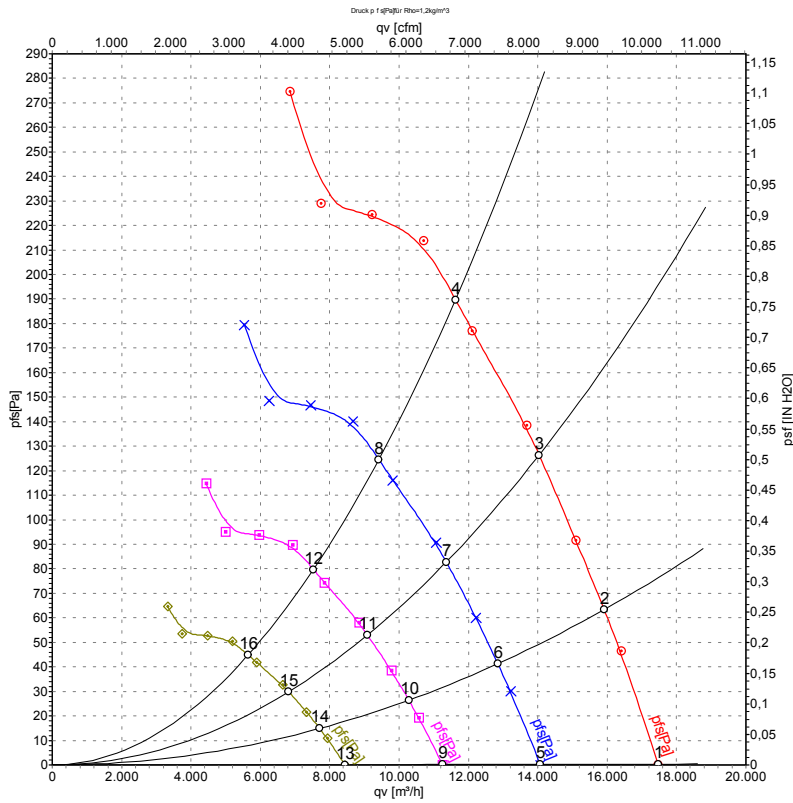

Measurement: LU-130208

Air performance measured as per ISO 5801 Installation category A. For detailed information on the measuring set-up, please contact ebmpapst. Suction-side noise levels: LwA measured as per ISO 13347 / LpA measured with 1m distance to fan axis. The values given are valid under the measuring conditions mentioned above and may vary according to the actual installation situation. With any deviation from the standard set-up, the specific values have to be checked and reviewed with the unit installed.

## Measured values

	U	f	n	P <sub>ed</sub>	I	LpA <sub>in</sub>	LwA <sub>in</sub>	LwA <sub>out</sub>	qv	p <sub>fs</sub>
	V	Hz	min <sup>-1</sup>	W	A	dB(A)	dB(A)	dB(A)	m <sup>3</sup> /h	Pa
1	400	50	1230	1390	2.14	68	76	77	17470	0
2	400	50	1230	1528	2.32	68	76	77	15920	64
3	400	50	1230	1651	2.52	68	76	76	14040	127
4	400	50	1230	1846	2.83	72	79	79	11620	190
5	400	50	1000	726	1.12	64	71	73	14070	0
6	400	50	1000	804	1.22	63	71	72	12850	41
7	400	50	1000	875	1.34	64	71	72	11360	83
8	400	50	1000	948	1.44	67	75	74	9415	124
9	400	50	800	372	0.57	59	67	68	11260	0
10	400	50	800	412	0.63	59	66	67	10280	26
11	400	50	800	448	0.68	59	66	67	9090	53
12	400	50	800	485	0.74	63	70	69	7535	80
13	400	50	600	157	0.24	53	60	61	8440	0
14	400	50	600	174	0.26	52	60	61	7710	15
15	400	50	600	189	0.29	53	60	61	6815	30
16	400	50	600	205	0.31	56	64	63	5650	45

