

Nominal data

Type	A3G630-AQ37-35	
Motor	M3G112-GA	
Phase		1~
Nominal voltage	VAC	230
Nominal voltage range	VAC	200 .. 277
Frequency	Hz	50/60
Type of data definition		ml
Speed	min ⁻¹	1000
Power input	W	720
Current draw	A	3.2
Max. back pressure	Pa	140
Min. ambient temperature	°C	-25
Max. ambient temperature	°C	60

ml = Max. load · me = Max. efficiency · fa = Running at free air · cs = Customer specs · cu = Customer unit
Subject to alterations

Data according to ErP directive

Installation category	A
Efficiency category	Static
Variable speed drive	Yes
Specific ratio*	1.00

* Specific ratio = $1 + p_b / 100\,000\text{ Pa}$

		Actual	Request 2013	Request 2015
Overall efficiency η_{es}	%	44.1	28.7	32.7
Efficiency grade N		51.4	36	40
Power input P_{ed}	kW	0.69		
Air flow q_v	m ³ /h	8080		
Pressure increase p_{fs}	Pa	124		
Speed n	min ⁻¹	1005		

Data definition with optimum efficiency. LU-116825
The ErP data is determined using a motor-impeller combination in a standardised measurement configuration.

Technical features

Mass	11 kg
Size	630 mm
Surface of rotor	Primed and coated in black
Material of terminal box	Die-cast aluminium, coated in black
Material of electronics housing	Die-cast aluminium, coated in black
Material of blades	Press-fitted, coated sheet steel blank, sprayed with PP plastic
Number of blades	5
Direction of air flow	"A"
Direction of rotation	Clockwise, seen on rotor
Type of protection	IP 54
Insulation class	"B"
Humidity class	F4-2
Max. permissible ambient motor temp. (transp./ storage)	+80 °C
Min. permissible ambient motor temp. (transp./storage)	-40 °C
Mounting position	Shaft horizontal or rotor on top; rotor on bottom on request
Condensate discharge holes	On the stator side
Operation mode	S1
Motor bearing	Ball bearing
Technical features	<ul style="list-style-type: none"> - Control input 0-10 VDC / PWM - Over-temperature protected electronics / motor - Alarm relay - PFC, active - Integrated PID controller - Input for sensor 0-10 V or 4-20 mA - Output for slave 0-10 V - RS485 ebmBUS - Line undervoltage detection - Motor current limit - Soft start - Output 10 VDC, max. 10 mA - Output 20 VDC, max. 50 mA - Control interface with SELV potential safely disconnected from the mains
EMC interference immunity	Acc. to EN 61000-6-2 (industrial environment)
EMC harmonics	Acc. to EN 61000-3-2/3
EMC interference emission	Acc. to EN 61000-6-4 (industrial environment)
Touch current acc. IEC 60990 (measuring network Fig. 4, TN system)	<= 3.5 mA
Electrical leads	Via terminal box
Motor protection	Thermal overload protector (TOP) wired internally
Protection class	I (if protective earth is connected by customer)
Product conforming to standard	EN 61800-5-1; CE
Approval	GOST

Product drawing

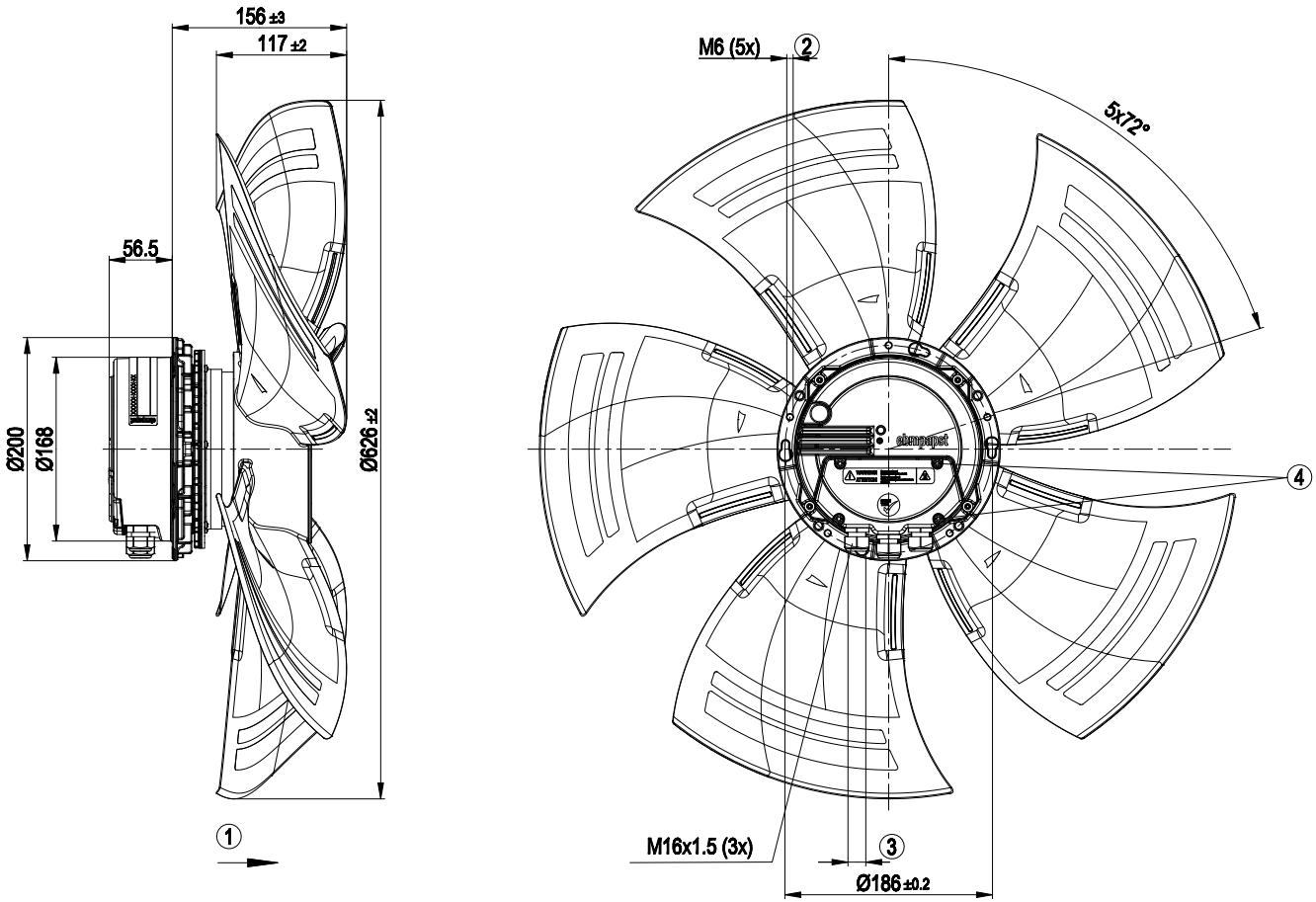

1	Direction of air flow "V"
2	Depth of screw max. 16 mm
3	Cable diameter: min. 4 mm, max. 10 mm, tightening torque: 2.5±0.4 Nm
4	Tightening torque 3.5±0.5 Nm

Connection screen

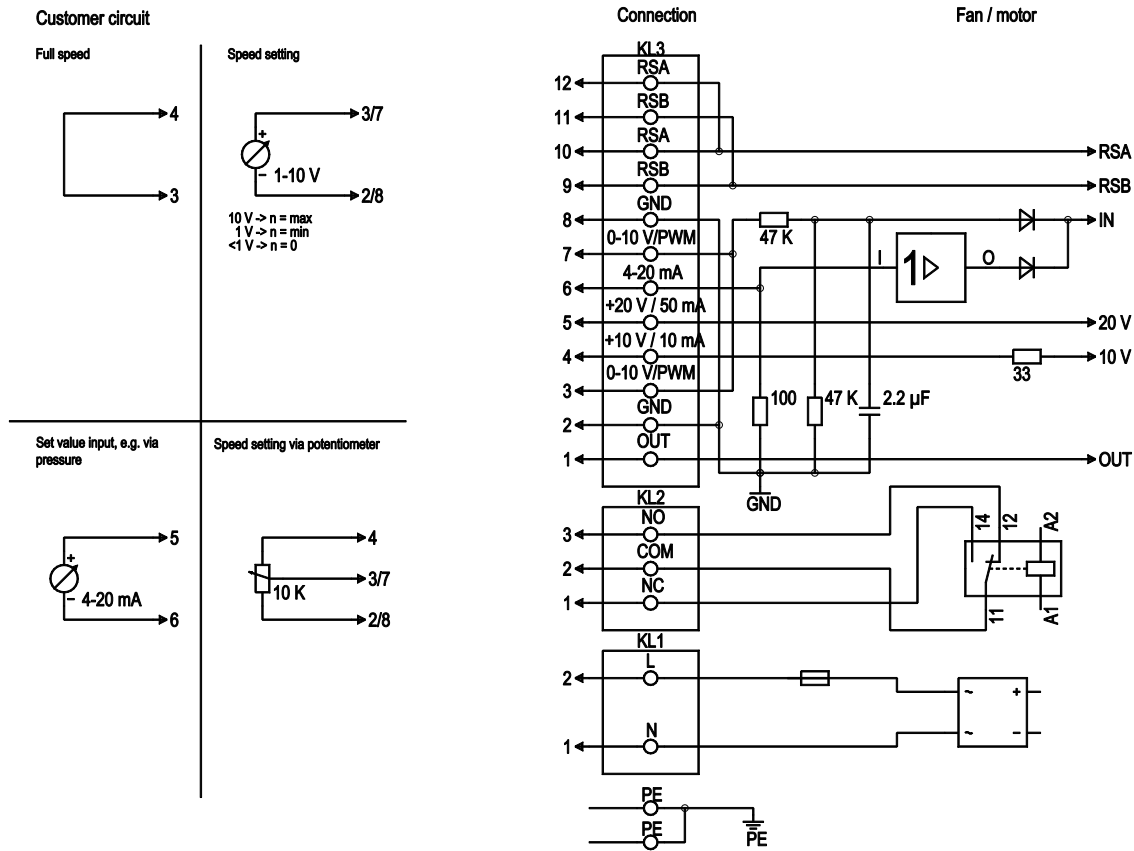

No.	Conn.	Designation	Function / assignment
PE		PE	Protective earth connection
KL1	1, 2	N, L	Supply voltage, 50/60 Hz
KL2	1	NC	Floating status message contact, normally closed connection
KL2	2	COM	Floating status message contact, changeover contact, common connection (2 A, max. 250 VAC, min. 10 mA, AC1)
KL2	3	NO	Floating status message contact, normally open connection
KL3	1	OUT	Analogue output, 0-10 VDC, max. 3 mA, SELV, Output of the current motor level control coefficient: 1 V corresponds to 10% level control coefficient, 10 V correspond to 100% level control coefficient.
KL3	2, 8	GND	Reference mass for control interface, SELV
KL3	3, 7	0-10 V	Use control / actual value input 0-10 VDC, impedance 100 kΩ only as alternative to 4-20 mA input, SELV
KL3	4	+10 V	Voltage output 10 VDC (+/-3%), max. 10 mA, supply voltage for ext. devices (e.g. potentiometer), SELV
KL3	5	+20 V	Voltage output 20 VDC (+25%/-10%), max. 50 mA, supply voltage for ext. devices (e.g. sensors), SELV
KL3	6	4-20 mA	Use control / actual value input 4-20 mA, impedance 100 Ω, only as alternative to 0-10 V input, SELV
KL3	9, 11	RSB	RS485 interface for ebmBus, RSB, SELV
KL3	10, 12	RSA	RS485 interface for ebmBus, RSA, SELV

Charts: Air flow 50 Hz

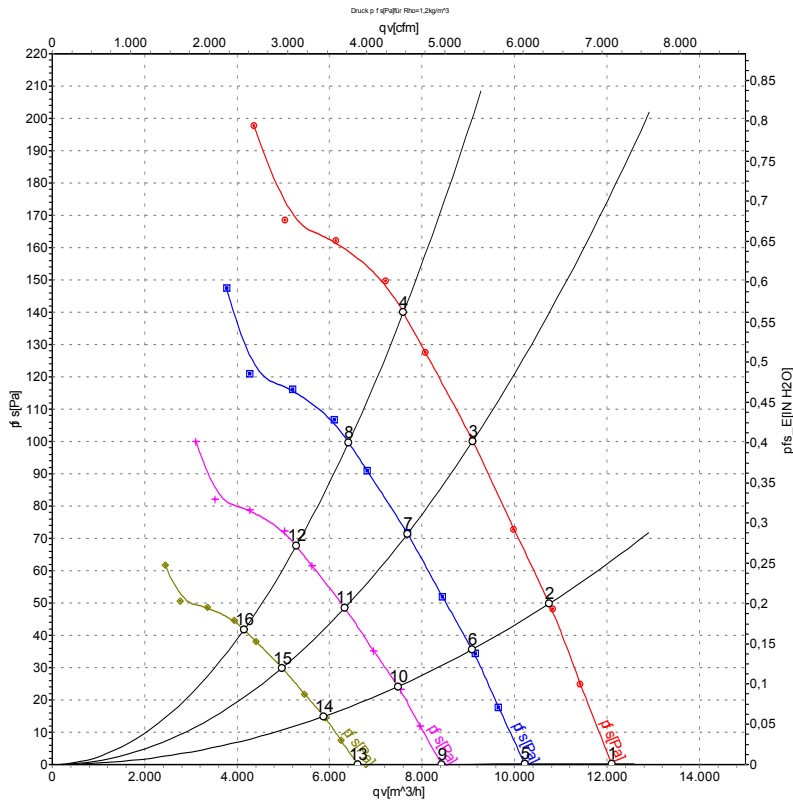

Air performance measured as per ISO 5801 Installation category A. For detailed information on the measuring set-up, please contact ebmpapst. Suction-side noise levels: LwA measured as per ISO 13347 / LpA measured with 1m distance to fan axis. The values given are valid under the measuring conditions mentioned above and may vary according to the actual installation situation. With any deviation from the standard set-up, the specific values have to be checked and reviewed with the unit installed.

Measured values

	U	f	n	P _{ed}	I	LpA _{in}	LwA _{in}	LwA _{out}	qv	p _{fs}
	V	Hz	min ⁻¹	W	A	dB(A)	dB(A)	dB(A)	m ³ /h	Pa
1	230	50	1000	462	2.11	65	71	71	12100	0
2	230	50	1000	559	2.54	61	68	67	10750	50
3	230	50	1000	653	2.94	62	69	68	9100	100
4	230	50	1000	720	3.20	64	71	70	7595	140
5	230	50	850	279	1.27	61	67	67	10230	0
6	230	50	850	337	1.53	58	64	64	9085	36
7	230	50	850	394	1.77	59	65	64	7685	72
8	230	50	850	429	1.93	61	67	67	6415	100
9	230	50	700	156	0.71	57	63	63	8420	0
10	230	50	700	188	0.86	53	60	60	7480	24
11	230	50	700	220	0.99	55	61	60	6330	49
12	230	50	700	240	1.08	57	63	63	5280	68
13	230	50	550	76	0.35	52	58	58	6615	0
14	230	50	550	91	0.42	48	55	54	5880	15
15	230	50	550	107	0.48	49	56	55	4975	30
16	230	50	550	116	0.52	51	58	57	4150	42

U = Supply voltage · f = Frequency · n = Speed · P_{ed} = Power input · I = Current draw · LpA_{in} = Sound pressure level inlet side · LwA_{in} = Sound power level inlet side · LwA_{out} = Sound power level outlet side
qv = Air flow · p_{fs} = Pressure increase

