

A3G630-AD03-A4 ebmpapst Datasheet

sales@fansco.com

www.fansco.com

Limited partnership · Headquarters Muldingen

Amtsgericht (court of registration) Stuttgart · HRA 590344

General partner Elektrobau Muldingen GmbH · Headquarters Muldingen

Amtsgericht (court of registration) Stuttgart · HRB 590142



## Nominal data

Type	A3G630-AD03-A4	
Motor	M3G084-GF	
Phase		1~
Nominal voltage	VAC	230
Nominal voltage range	VAC	200 .. 277
Frequency	Hz	50/60
Method of obtaining data		ml
Speed (rpm)	min <sup>-1</sup>	800
Power consumption	W	280
Current draw	A	1.2
Max. back pressure	Pa	75
Max. back pressure	inH <sub>2</sub> O	0.3
Min. ambient temperature	°C	-25
Max. ambient temperature	°C	60

ml = Max. load · me = Max. efficiency · fa = Free air · cs = Customer specification · ce = Customer equipment  
Subject to change

## Data according to ErP Directive

		Actual	Req. 2015			
01 Overall efficiency $\eta_{es}$	%	42.3	29.8	09 Power consumption $P_{ed}$	kW	0.24
02 Measurement category		A		09 Air flow $q_v$	m <sup>3</sup> /h	6570
03 Efficiency category		Static		09 Pressure increase $p_{fs}$	Pa	52
04 Efficiency grade N		52.5	40	10 Speed (rpm) n	min <sup>-1</sup>	805
05 Variable speed drive		Yes		11 Specific ratio*		1.00

Data obtained at optimum efficiency level.

The ErP data is determined using a motor-impeller combination in a standardized measurement setup.

\* Specific ratio =  $1 + p_s / 100\,000\text{ Pa}$ 

LU-126911



## Technical description

Weight	6 kg
Fan size	630 mm
Rotor surface	Painted black
Electronics housing material	Die-cast aluminum
Blade material	Press-fitted sheet steel blank, sprayed with PP plastic
Number of blades	5
Airflow direction	"A"
Direction of rotation	Clockwise, viewed toward rotor
Degree of protection	IP54
Insulation class	"B"
Moisture (F) / Environmental (H) protection class	F3-1
Max. permitted ambient temp. for motor (transport/storage)	+ 80 °C
Min. permitted ambient temp. for motor (transport/storage)	- 40 °C
Installation position	Shaft horizontal or rotor on bottom; rotor on top on request
Condensation drainage holes	On rotor side
Mode	S1
Motor bearing	Ball bearing
Technical features	<ul style="list-style-type: none"> <li>- Output 10 VDC, max. 10 mA</li> <li>- Alarm relay</li> <li>- Motor current limitation</li> <li>- PFC, active</li> <li>- Soft start</li> <li>- Control input 0-10 VDC / PWM</li> <li>- Control interface with SELV potential safely disconnected from the mains</li> <li>- Thermal overload protection for electronics/motor</li> <li>- Line undervoltage / phase failure detection</li> </ul>
EMC immunity to interference	According to EN 61000-6-2 (industrial environment)
EMC circuit feedback	According to EN 61000-3-2/3
EMC interference emission	According to EN 55022 (Class B, household environment)
Touch current according to IEC 60990 (measuring circuit Fig. 4, TN system)	<= 3.5 mA
Motor protection	Thermal overload protector (TOP) internally connected
With cable	Variable
Protection class	I (with customer connection of protective earth)
Conformity with standards	EN 61800-5-1; CE

Product drawing

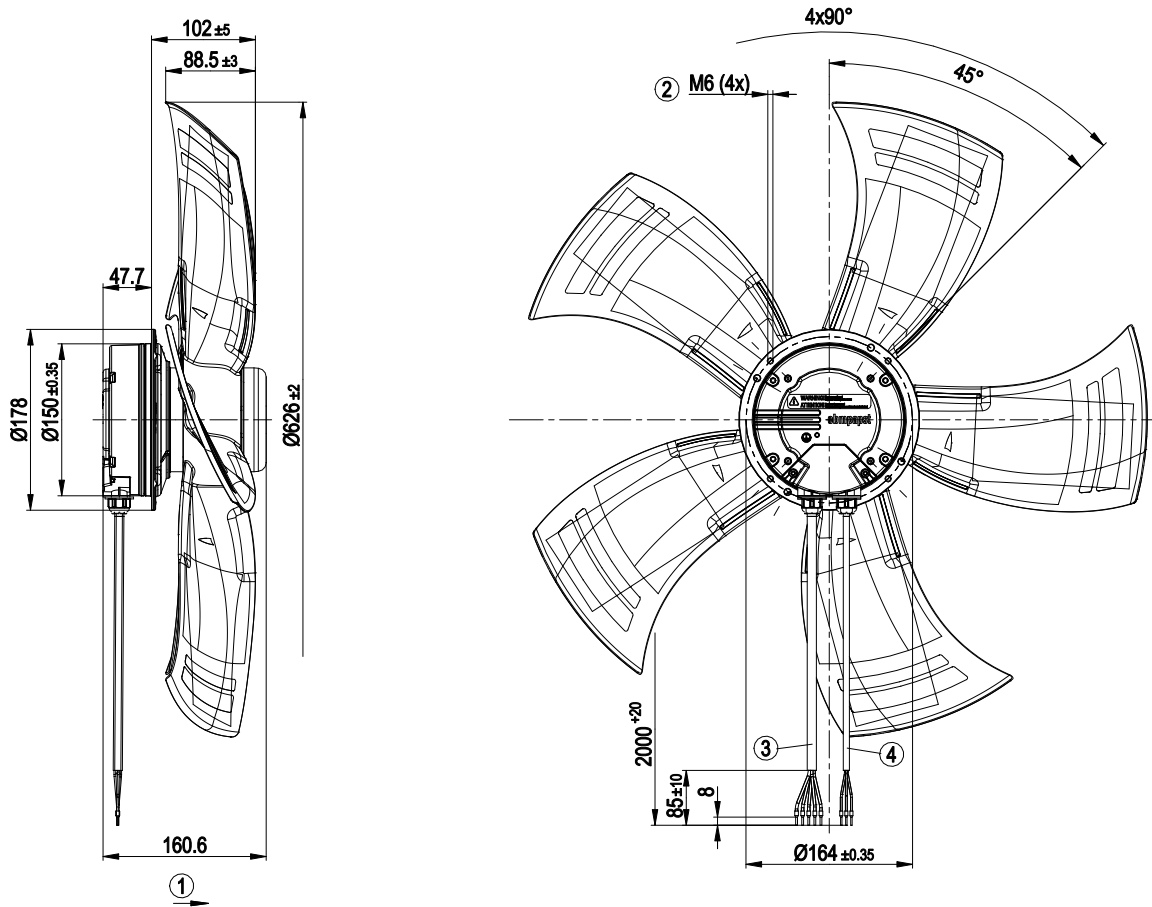

1	Direction of air flow "A"
2	Max. clearance for screw 10 mm
3	Cable PVC AWG18, 5x crimped ferrule
4	Cable PVC AWG22, 3x crimped ferrules

## Connection diagram

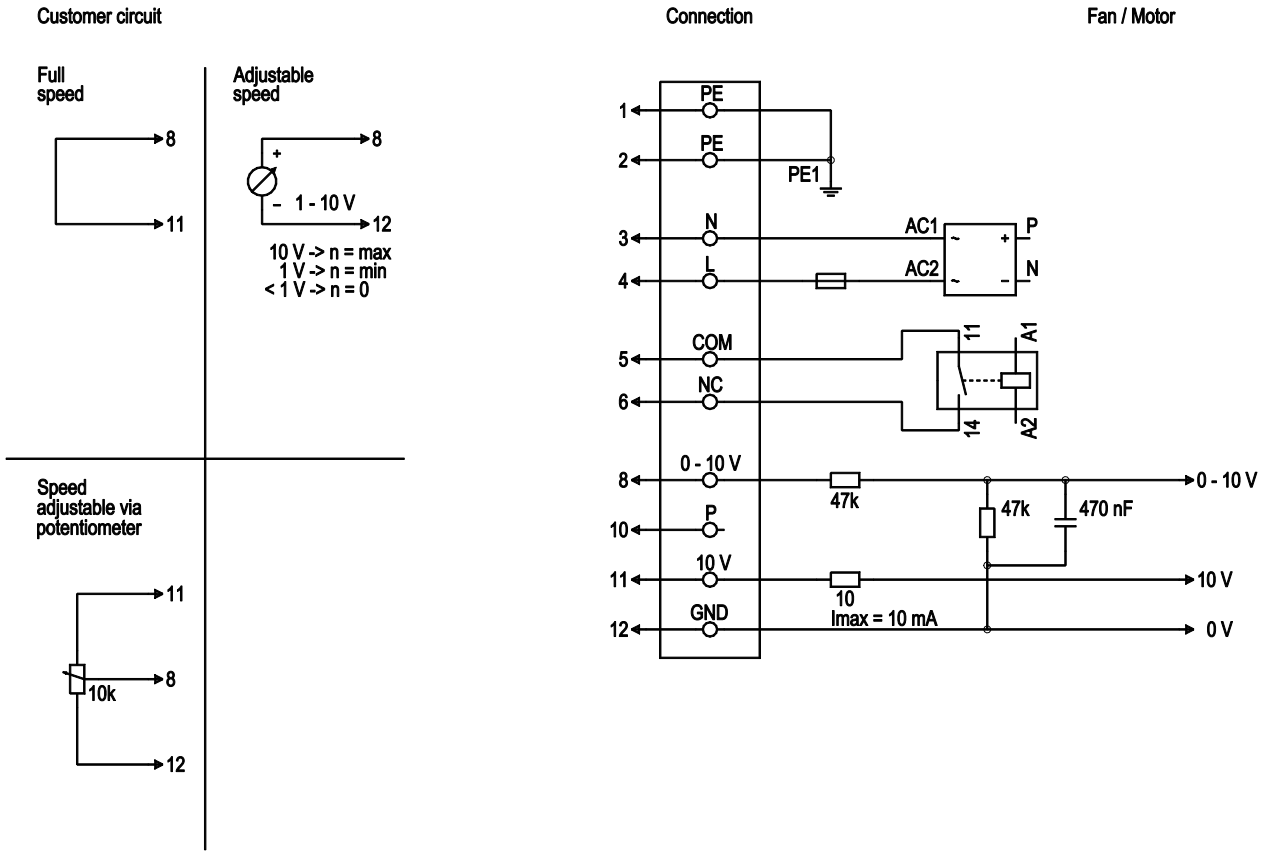

No.	Conn.	Designation	Color	Function/assignment
1	1, 2	PE	green/yellow	Protective earth
1	3	N	blue	Power supply, neutral conductor, see nameplate for voltage range, 50/60 Hz
1	4	L	black	Power supply, phase, see nameplate for voltage range, 50/60 Hz
1	5	COM	white 1	Floating status contact, break for failure (2 A, max. 250 VAC, min. 10 mA)
1	6	NC	white 2	Floating status contact, break for failure
2	8	0 - 10 V	yellow	Control input, set value 0-10 VDC, impedance 100 kOhm, SELV
2	10	P	orange	not used
2	11	10 VDC	red	Voltage output 10 VDC ( $\pm 3\%$ ), max. 10 mA, power supply for external devices (e.g. potentiometers), SELV
2	12	GND	blue	Reference ground for control interface, SELV

## Curves: Air performance 50 Hz

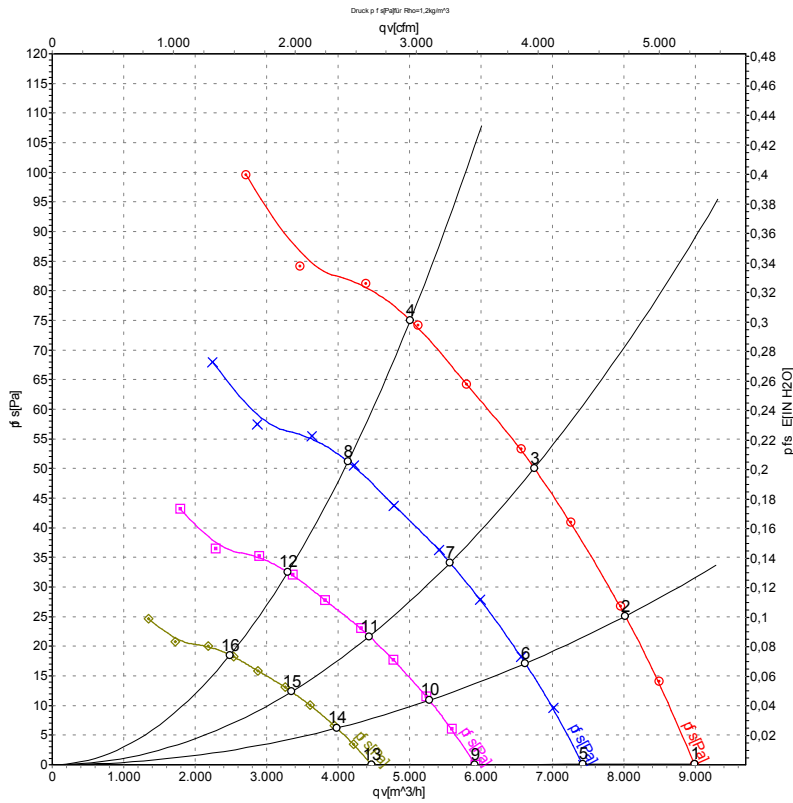

Measurement: LU-126911-1

Air performance measured according to ISO 5801 installation category A. For detailed information on the measurement setup, contact ebmpapst. Intake sound level: Sound power level according to ISO 13347 / sound pressure level measured at 1 m distance from fan axis. The values given are valid under the specified measuring conditions and may vary due to conditions of installation. For deviations from the standard configuration, the parameters have to be checked on the installed unit.

## Measured values

	U	f	n	P <sub>ed</sub>	I	LpA <sub>in</sub>	LwA <sub>in</sub>	LwA <sub>out</sub>	qv	P <sub>fs</sub>	qv	P <sub>fs</sub>
	V	Hz	min <sup>-1</sup>	W	A	dB(A)	dB(A)	dB(A)	m <sup>3</sup> /h	Pa	CFM	inH <sub>2</sub> O
1	230	50	800	170	0.76	56	63	62	8985	0	5290	0.00
2	230	50	800	211	0.93	57	63	62	8015	25	4715	0.10
3	230	50	800	245	1.08	57	63	62	6745	50	3970	0.20
4	230	50	800	280	1.20	60	67	67	5010	75	2950	0.30
5	230	50	665	96	0.43	52	59	58	7420	0	4365	0.00
6	230	50	665	119	0.53	53	59	58	6620	17	3895	0.07
7	230	50	665	138	0.61	53	59	58	5565	34	3275	0.14
8	230	50	665	155	0.68	56	63	63	4135	51	2435	0.20
9	230	50	530	49	0.22	47	54	53	5915	0	3480	0.00
10	230	50	530	60	0.27	48	54	53	5275	11	3105	0.04
11	230	50	530	70	0.31	48	54	53	4435	22	2610	0.09
12	230	50	530	79	0.35	51	58	58	3295	33	1940	0.13
13	230	50	400	21	0.09	41	48	47	4465	0	2625	0.00
14	230	50	400	26	0.11	42	47	47	3980	6	2345	0.02
15	230	50	400	30	0.13	42	48	47	3350	12	1970	0.05
16	230	50	400	34	0.15	45	52	52	2485	19	1465	0.08

U = Power supply · f = Frequency · n = Speed (rpm) · P<sub>ed</sub> = Power consumption · I = Current draw · LpA<sub>in</sub> = Sound pressure level intake side · LwA<sub>in</sub> = Sound power level intake side  
 LwA<sub>out</sub> = Sound power level outlet side · qv = Air flow · p<sub>fs</sub> = Pressure increase

