



A3G630-AC52-58 ebmpapst Datasheet

sales@fansco.com

www.fansco.com

Limited partnership · Headquarters Muldingen

Amtsgericht (court of registration) Stuttgart · HRA 590344

General partner Elektrobau Muldingen GmbH · Headquarters Muldingen

Amtsgericht (court of registration) Stuttgart · HRB 590142



Nominal data

Type	A3G630-AC52-58	
Motor	M3G084-FA	
Phase		1~
Nominal voltage	VAC	230
Nominal voltage range	VAC	200 .. 277
Frequency	Hz	50/60
Method of obtaining data		ml
Speed (rpm)	min ⁻¹	690
Power consumption	W	184
Current draw	A	1.2
Max. back pressure	Pa	55
Max. back pressure	inH2O	0.22
Min. ambient temperature	°C	-25
Max. ambient temperature	°C	60

ml = Max. load · me = Max. efficiency · fa = Free air · cs = Customer specification · ce = Customer equipment
Subject to change

Data according to ErP Directive

		Actual	Req. 2015			
01 Overall efficiency η_{es}	%	41.5	29	09 Power consumption P_{ed}	kW	0.18
02 Measurement category		A		09 Air flow q_v	m ³ /h	4985
03 Efficiency category		Static		09 Pressure increase p_{fs}	Pa	48
04 Efficiency grade N		52.5	40	10 Speed (rpm) n	min ⁻¹	700
05 Variable speed drive		Yes		11 Specific ratio*		1.00

Data obtained at optimum efficiency level.
The ErP data is determined using a motor-impeller combination in a standardized measurement setup.

* Specific ratio = $1 + p_s / 100\,000\text{ Pa}$

LU-116824



Technical description

Weight	5.2 kg
Fan size	630 mm
Rotor surface	Painted black
Terminal box material	PC/ABS plastic
Electronics housing material	Die-cast aluminum
Blade material	Press-fitted sheet steel blank, sprayed with PP-GF40 plastic
Number of blades	5
Airflow direction	"V"
Direction of rotation	Counterclockwise, viewed toward rotor
Degree of protection	IP54
Insulation class	"B"
Moisture (F) / Environmental (H) protection class	F3-1
Max. permitted ambient temp. for motor (transport/storage)	80 °C
Min. permitted ambient temp. for motor (transport/storage)	-40 °C
Installation position	Shaft horizontal or rotor on bottom; rotor on top on request
Condensation drainage holes	On rotor side
Mode	S1
Motor bearing	Ball bearing
Technical features	<ul style="list-style-type: none"> - Output 10 VDC, max. 10 mA - Alarm relay - Motor current limitation - Soft start - Control input 0-10 VDC / PWM - Control interface with SELV potential safely disconnected from supply - Thermal overload protection for electronics/motor
EMC immunity to interference	According to EN 61000-6-2 (industrial environment)
EMC circuit feedback	According to EN 61000-3-2/3
EMC interference emission	According to EN 61000-6-3 (household environment)
Touch current according to IEC 60990 (measuring circuit Fig. 4, TN system)	<= 3.5 mA
Electrical hookup	Via terminal box
Motor protection	Thermal overload protector (TOP) internally connected
Protection class	I (with customer connection of protective earth)
Conformity with standards	EN 60335-1; CE
Approval	EAC

Product drawing

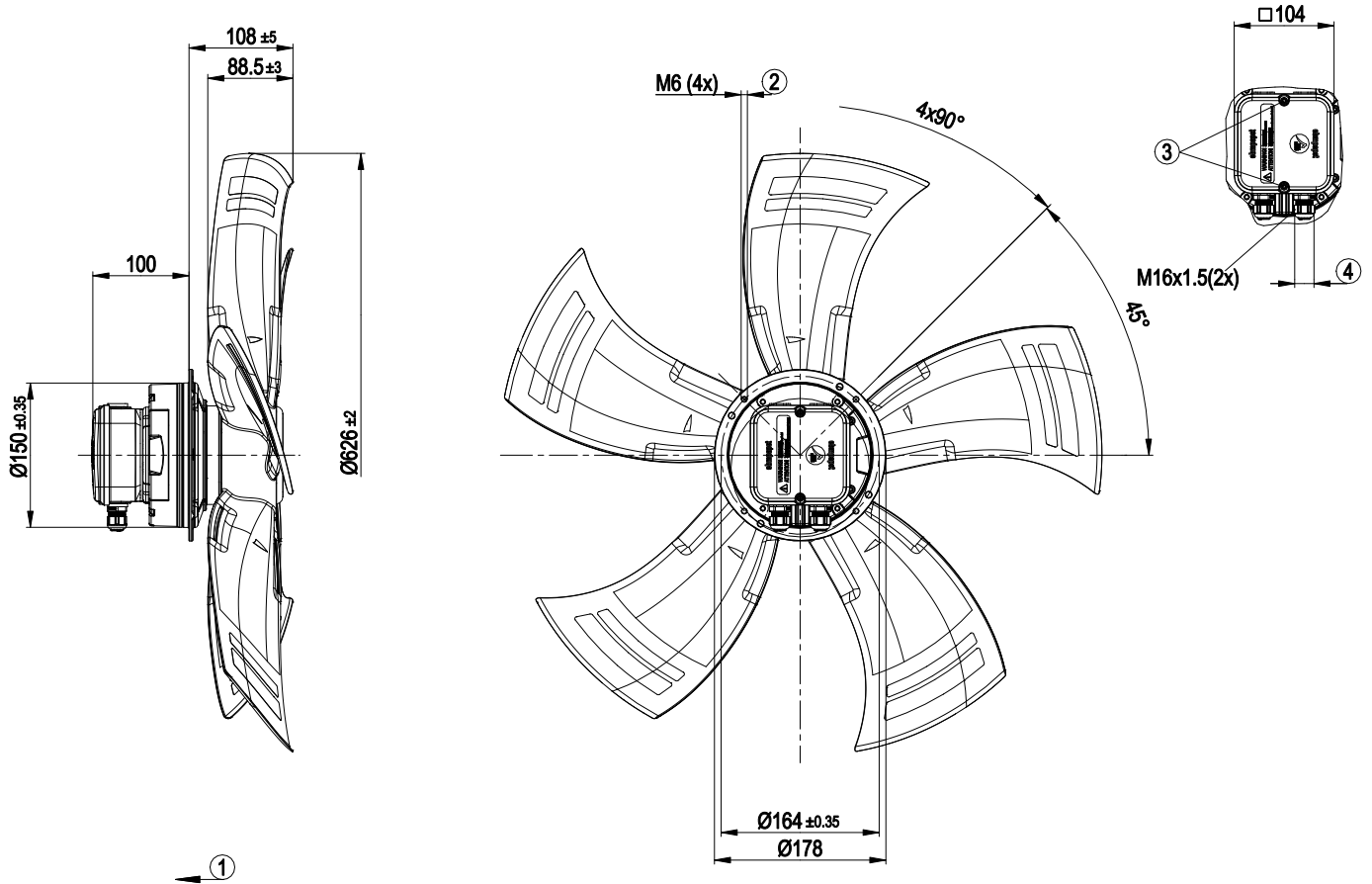

1	Direction of air flow "V"
2	Max. clearance for screw 10 mm
3	Tightening torque 1.5±0.2Nm
4	Cable diameter min. 4 mm, max. 10 mm, tightening torque 2.5±0.4 Nm

Connection diagram

Customer circuit

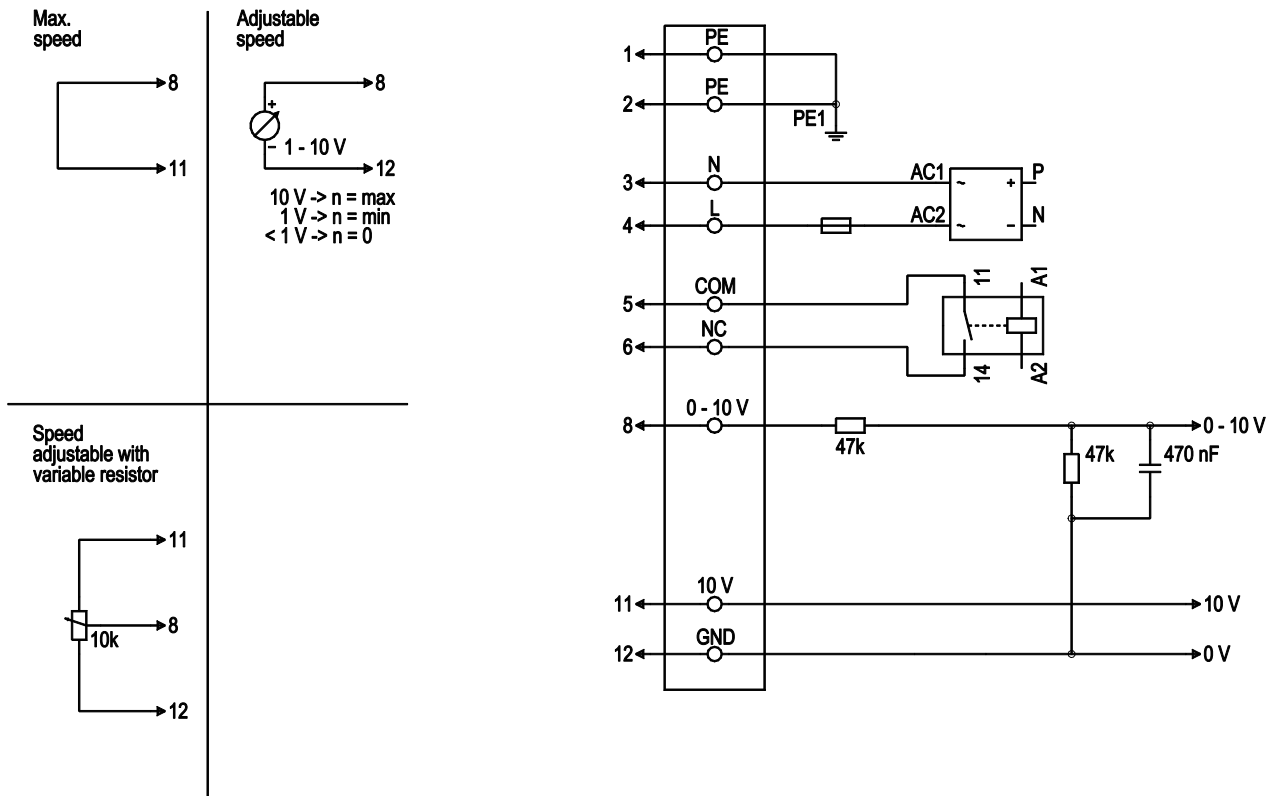

No.	Conn.	Designation	Color	Function/assignment
1	1,2	PE	green/yellow	Protective earth
1	3	N	blue	Power supply, neutral conductor, 50/60 Hz
1	4	L	black	Power supply, phase, 50/60 Hz
1	5	COM	white 1	Floating status contact, break for failure (2 A, max. 250 VAC, min. 10 mA, AC1)
1	6	NC	white 2	Floating status contact, break for failure
2	8	0 - 10 V	yellow	Control input, set value 0-10 VDC, impedance 100 kOhm, SELV
2	11	10 VDC	red	Voltage output 10 VDC (±3%), max. 10 mA, power supply for external devices (e.g. potentiometers), SELV
2	12	GND	blue	Reference ground for control interface, SELV

Curves: Air performance 50 Hz

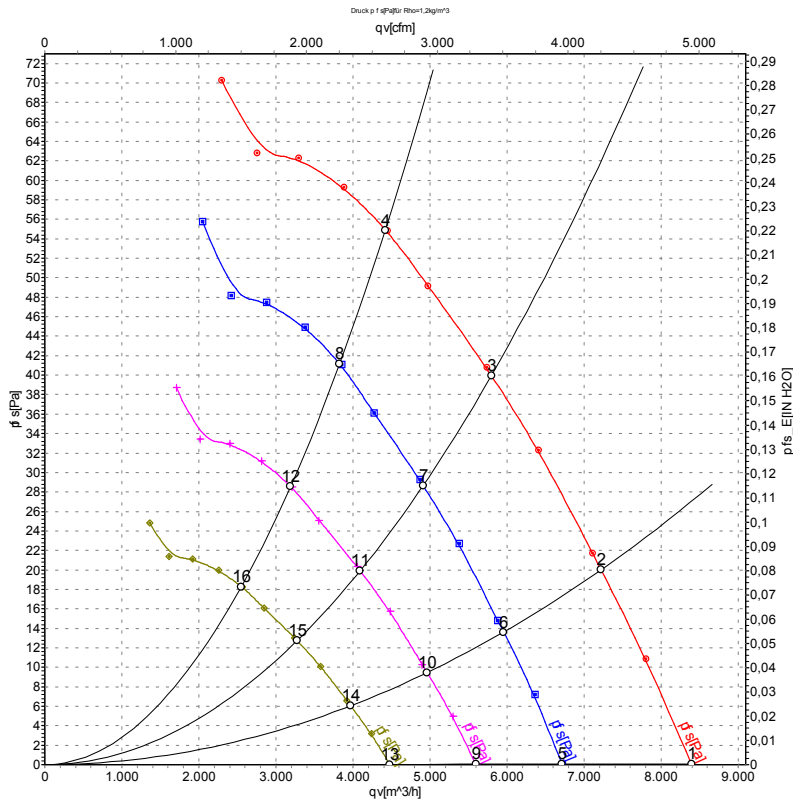

Measurement: LU-116824-1

Air performance measured according to ISO 5801 installation category A. For detailed information on the measurement setup, contact ebmpapst. Intake sound level: Sound power level according to ISO 13347 / sound pressure level measured at 1 m distance from fan axis. The values given are valid under the specified measuring conditions and may vary due to conditions of installation. For deviations from the standard configuration, the parameters have to be checked on the installed unit.

Measured values

	U	f	n	P _{ed}	I	LpA _{in}	LwA _{in}	LwA _{out}	qv	P _{fs}	qv	P _{fs}
	V	Hz	min ⁻¹	W	A	dB(A)	dB(A)	dB(A)	m ³ /h	Pa	CFM	inH ₂ O
1	230	50	750	141	0.90	55	61	60	8395	0	4940	0.00
2	230	50	730	158	1.01	55	60	60	7220	20	4250	0.08
3	230	50	710	174	1.10	55	61	60	5800	40	3415	0.16
4	230	50	690	184	1.20	56	63	63	4420	55	2605	0.22
5	230	50	600	72	0.46	50	56	55	6715	0	3955	0.00
6	230	50	600	89	0.56	51	56	55	5955	14	3505	0.06
7	230	50	600	106	0.67	51	57	56	4910	29	2890	0.12
8	230	50	600	119	0.75	53	60	60	3830	41	2255	0.16
9	230	50	500	42	0.27	46	52	52	5595	0	3295	0.00
10	230	50	500	51	0.33	47	52	51	4965	10	2920	0.04
11	230	50	500	61	0.39	47	53	52	4095	20	2410	0.08
12	230	50	500	69	0.43	49	56	56	3190	29	1880	0.12
13	230	50	400	21	0.14	41	47	47	4475	0	2635	0.00
14	230	50	400	26	0.17	42	47	47	3970	6	2335	0.02
15	230	50	400	31	0.20	42	48	47	3275	13	1930	0.05
16	230	50	400	35	0.22	44	51	51	2550	18	1500	0.07

U = Power supply · f = Frequency · n = Speed (rpm) · P_{ed} = Power consumption · I = Current draw · LpA_{in} = Sound pressure level intake side · LwA_{in} = Sound power level intake side
 LwA_{out} = Sound power level outlet side · qv = Air flow · P_{fs} = Pressure increase

