



A3G630-AC52-51 ebmpapst Datasheet
 sales@fansco.com
 www.fansco.com

Nominal data

Type	A3G630-AC52-51	
Motor	M3G084-FA	
Phase		1~
Nominal voltage	VAC	230
Nominal voltage range	VAC	200 .. 277
Frequency	Hz	50/60
Type of data definition		ml
Speed	min ⁻¹	690
Power input	W	184
Current draw	A	1.2
Max. back pressure	Pa	55
Min. ambient temperature	°C	-25
Max. ambient temperature	°C	60

ml = Max. load · me = Max. efficiency · fa = Running at free air · cs = Customer specs · cu = Customer unit
 Subject to alterations

Data according to ErP directive

Installation category	A
Efficiency category	Static
Variable speed drive	Yes
Specific ratio*	1.00

* Specific ratio = $1 + p_b / 100\,000\text{ Pa}$

		Actual	Request 2013	Request 2015
Overall efficiency η_{es}	%	41.5	25	29
Efficiency grade N		52.5	36	40
Power input P_{ed}	kW	0.18		
Air flow q_v	m ³ /h	4985		
Pressure increase p_{fs}	Pa	48		
Speed n	min ⁻¹	700		

Data definition with optimum efficiency. LU-116824
 The ErP data is determined using a motor-impeller combination in a standardised measurement configuration.



Technical features

Mass	5.1 kg
Size	630 mm
Surface of rotor	Coated in black
Material of electronics housing	Die-cast aluminium
Material of blades	Press-fitted sheet steel blank, sprayed with PP plastic
Number of blades	5
Direction of air flow	"V"
Direction of rotation	Counter-clockwise, seen on rotor
Type of protection	IP 54; Depending on installation and position
Insulation class	"B"
Humidity class	F3-1
Max. permissible ambient motor temp. (transp./ storage)	80 °C
Min. permissible ambient motor temp. (transp./storage)	-40 °C
Mounting position	Shaft horizontal or rotor on bottom; rotor on top on request
Condensate discharge holes	Rotor-side
Operation mode	S1
Motor bearing	Ball bearing
Technical features	<ul style="list-style-type: none"> - Output 10 VDC, max. 10 mA - Alarm relay - Motor current limit - Soft start - Control input 0-10 VDC / PWM - Control interface with SELV potential safely disconnected from the mains - Over-temperature protected electronics / motor
EMC interference immunity	Acc. to EN 61000-6-2 (industrial environment)
EMC harmonics	Acc. to EN 61000-3-2/3
EMC interference emission	Acc. to EN 61000-6-3 (household environment)
Touch current acc. IEC 60990 (measuring network Fig. 4, TN system)	<= 3.5 mA
Motor protection	Thermal overload protector (TOP) wired internally
Cable exit	Variable
Protection class	I (if protective earth is connected by customer)
Product conforming to standard	EN 60335-1; CE
Approval	EAC

Product drawing

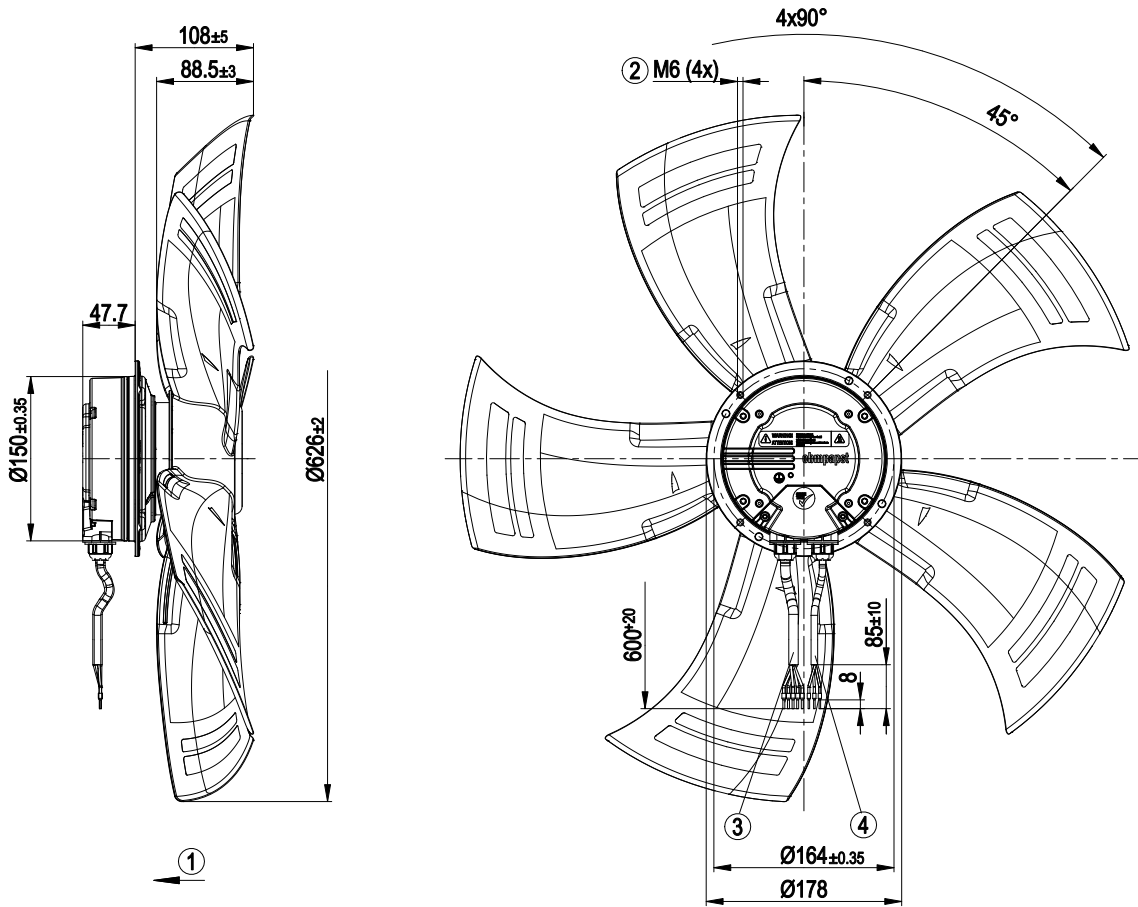

1	Direction of air flow "V"
2	Depth of screw max. 10 mm
3	Connection line PVC AWG18, 5x crimped core-end sleeves
4	Connection line PVC AWG22, 3x crimped core-end sleeves

Connection screen

Customer circuit

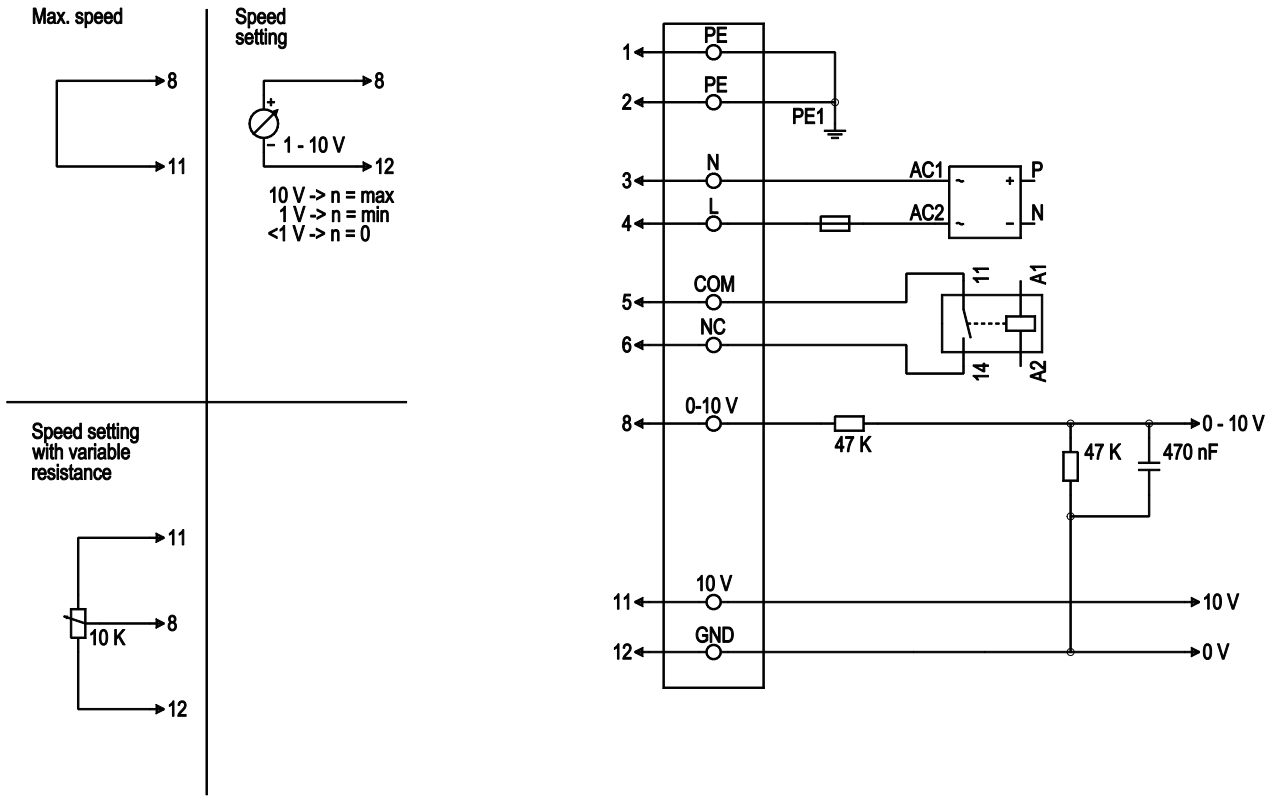

No.	Conn.	Designation	Colour	Function / assignment
1	1,2	PE	green/yellow	Protective earth
1	3	N	blue	Supply voltage, neutral conductor, 50/60 Hz
1	4	L	black	Supply voltage, phase, 50/60 Hz
1	5	COM	white 1	Floating status message contact, break for failure (2 A, max. 250 VAC, min. 10 mA, AC1)
1	6	NC	white 2	Floating status message contact, break for failure
2	8	0 - 10 V	yellow	Control input, set value 0 - 10 VDC, impedance 100 kOhm, SELV
2	11	10 VDC	red	Voltage output 10 VDC (+/-3%), max. 10 mA, supply voltage for ext. devices (e.g. potentiometer), SELV
2	12	GND	blue	Reference mass for control interface, SELV

Charts: Air flow 50 Hz

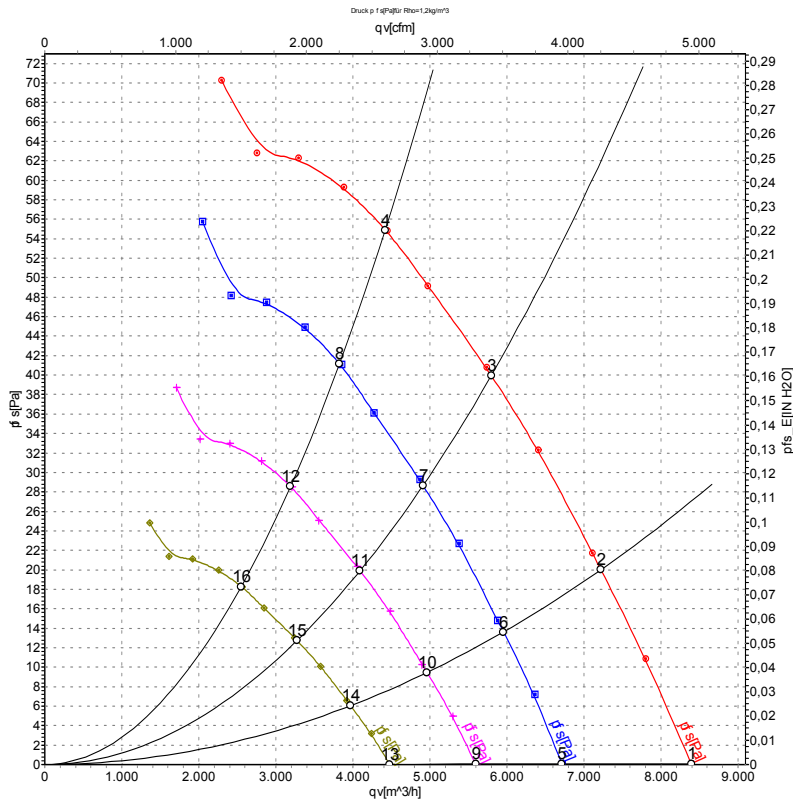

Air performance measured as per ISO 5801 Installation category A. For detailed information on the measuring set-up, please contact ebmpapst. Suction-side noise levels: LwA measured as per ISO 13347 / LpA measured with 1m distance to fan axis. The values given are valid under the measuring conditions mentioned above and may vary according to the actual installation situation. With any deviation from the standard set-up, the specific values have to be checked and reviewed with the unit installed.

Measured values

	U	f	n	P _{ed}	I	LpA _{in}	LwA _{in}	LwA _{out}	qv	p _{fs}
	V	Hz	min ⁻¹	W	A	dB(A)	dB(A)	dB(A)	m ³ /h	Pa
1	230	50	750	141	0.90	55	61	60	8395	0
2	230	50	730	158	1.01	55	60	60	7220	20
3	230	50	710	174	1.10	55	61	60	5800	40
4	230	50	690	184	1.20	56	63	63	4420	55
5	230	50	600	72	0.46	50	56	55	6715	0
6	230	50	600	89	0.56	51	56	55	5955	14
7	230	50	600	106	0.67	51	57	56	4910	29
8	230	50	600	119	0.75	53	60	60	3830	41
9	230	50	500	42	0.27	46	52	52	5595	0
10	230	50	500	51	0.33	47	52	51	4965	10
11	230	50	500	61	0.39	47	53	52	4095	20
12	230	50	500	69	0.43	49	56	56	3190	29
13	230	50	400	21	0.14	41	47	47	4475	0
14	230	50	400	26	0.17	42	47	47	3970	6
15	230	50	400	31	0.20	42	48	47	3275	13
16	230	50	400	35	0.22	44	51	51	2550	18

U = Supply voltage · f = Frequency · n = Speed · P_{ed} = Power input · I = Current draw · LpA_{in} = Sound pressure level inlet side · LwA_{in} = Sound power level inlet side · LwA_{out} = Sound power level outlet side
 qv = Air flow · p_{fs} = Pressure increase

