



A3G500-AM56-21 ebmpapst Datasheet

sales@fansco.com

www.fansco.com

Limited partnership · Headquarters Mulfingen  
County court Stuttgart · HRA 590344

General partner Elektrobau Mulfingen GmbH · Headquarters Mulfingen  
County court Stuttgart · HRB 590142

## Nominal data

Type	A3G500-AM56-21	
Motor	M3G112-EA	
Phase		1~
Nominal voltage	VAC	230
Nominal voltage range	VAC	200 .. 277
Frequency	Hz	50/60
Type of data definition		ml
Speed (rpm)	min <sup>-1</sup>	1420
Power input	W	750
Current draw	A	3.4
Max. back pressure	Pa	175
Min. ambient temperature	°C	-25
Max. ambient temperature	°C	60

ml = Max. load · me = Max. efficiency · fa = Running at free air · cs = Customer specs · cu = Customer unit  
Subject to alterations

## Data according to ErP directive

		Actual	Request 2015		
01 Overall efficiency $\eta_{es}$	%	41.6	32.8	09 Power input $P_{ed}$	kW 0.73
02 Measurement category		A		09 Air flow $q_v$	m <sup>3</sup> /h 5850
03 Efficiency category		Static		09 Pressure increase $p_{fs}$	Pa 173
04 Efficiency grade N		48.8	40	10 Speed (rpm) n	min <sup>-1</sup> 1425
05 Variable speed drive		Yes		11 Specific ratio <sup>*</sup>	1.00

Data definition with optimum efficiency.  
The ErP data is determined using a motor-impeller combination in a standardised measurement configuration.

<sup>\*</sup> Specific ratio =  $1 + p_{fs} / 100\,000\text{ Pa}$

LU-121382



## Technical features

Mass	7.6 kg
Size	500 mm
Surface of rotor	Coated in black
Material of electronics housing	Die-cast aluminium, coated in black
Material of blades	Press-fitted sheet steel blank, sprayed with PP plastic
Number of blades	5
Direction of air flow	"V"
Direction of rotation	Counter-clockwise, seen on rotor
Type of protection	IP 54
Insulation class	"B"
Humidity (F)/environmental protection class (H)	F4-1
Max. permissible ambient motor temp. (transp./ storage)	+ 80 °C
Min. permissible ambient motor temp. (transp./storage)	- 40 °C
Mounting position	Shaft horizontal or rotor on bottom; rotor on top on request
Condensate discharge holes	Rotor-side
Operation mode	S1
Motor bearing	Ball bearing
Technical features	<ul style="list-style-type: none"> <li>- Output 10 VDC, max. 10 mA</li> <li>- Alarm relay</li> <li>- Motor current limit</li> <li>- PFC, active</li> <li>- Soft start</li> <li>- Control input 0-10 VDC Control interface with SELV potential safely disconnected from the mains</li> <li>- Over-temperature protected electronics / motor</li> <li>- Line undervoltage / phase failure detection</li> </ul>
EMC interference immunity	Acc. to EN 61000-6-2 (industrial environment)
EMC harmonics	Acc. to EN 61000-3-2/3
EMC interference emission	Acc. to EN 61000-6-4 (industrial environment)
Touch current acc. IEC 60990 (measuring network Fig. 4, TN system)	<= 3.5 mA
Motor protection	Thermal overload protector (TOP) wired internally
Cable exit	Variable
Protection class	I (if protective earth is connected by customer)
Product conforming to standard	EN 61800-5-1; CE
Approval	CCC; EAC



Product drawing

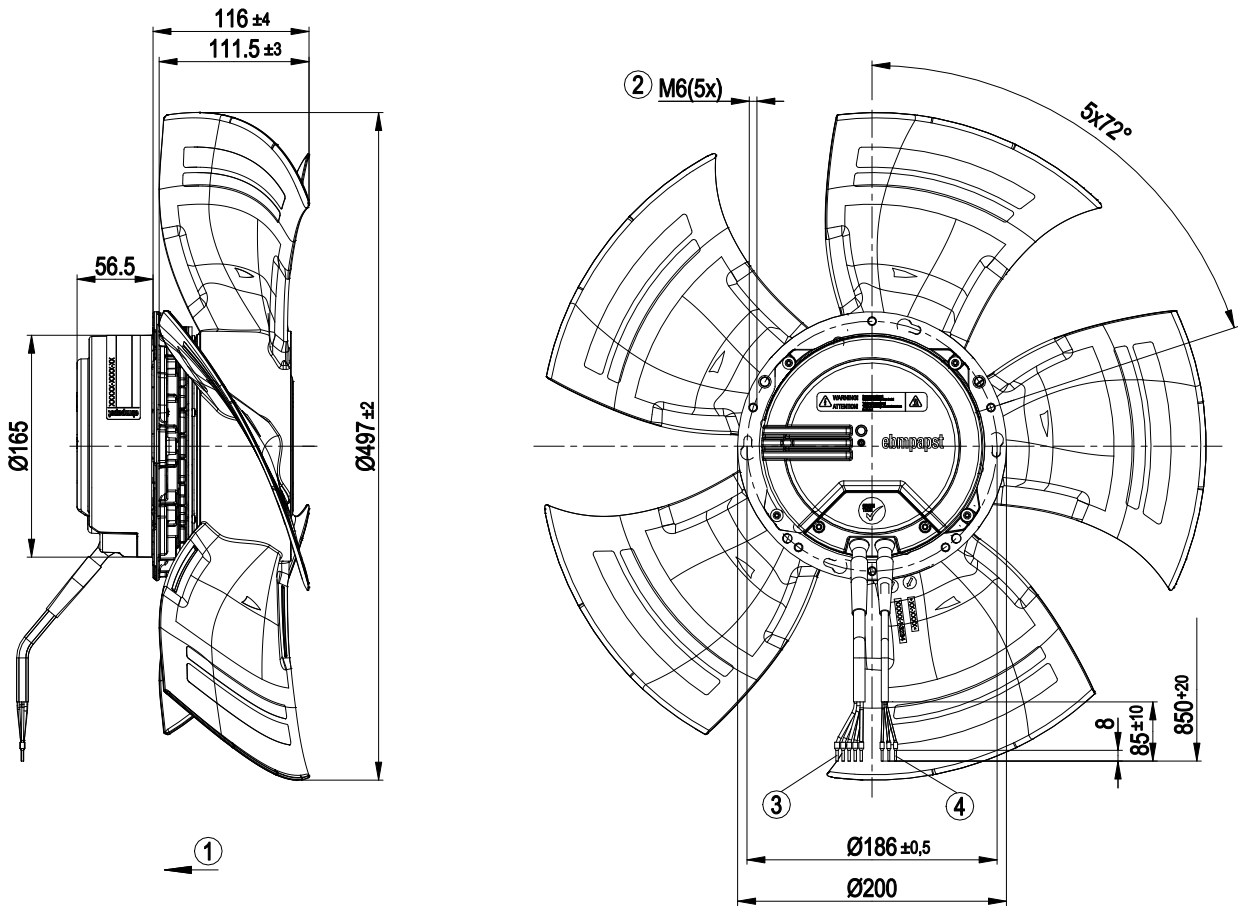

1	Direction of air flow "V"
2	Depth of screw max. 12 - 16 mm
3	Connection line PVC AWG18, 5x crimped core-end sleeves
4	Connection line PVC AWG22, 3x crimped core-end sleeves



## Connection screen

### Customer circuit

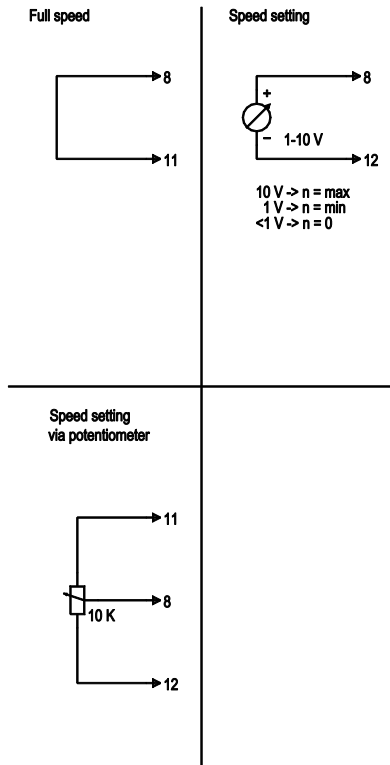

### Connection

### Fan / motor

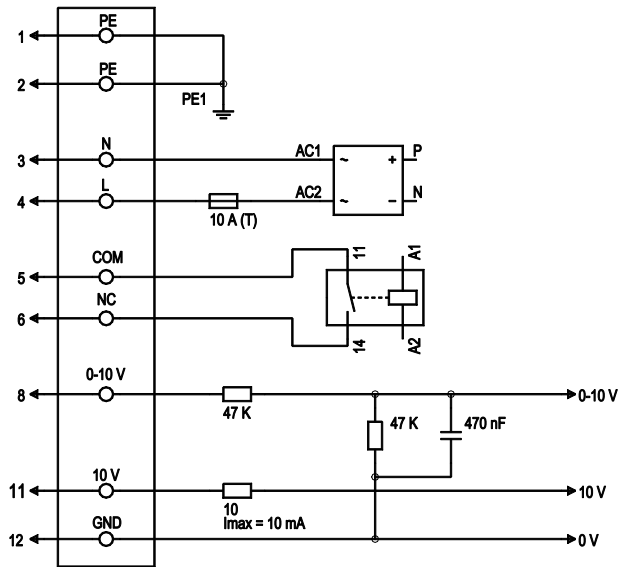

No.	Conn.	Designation	Colour	Function / assignment
1	1,2	PE	green/yellow	Protective earth
1	3	N	blue	Supply voltage, neutral conductor, 50/60 Hz
1	4	L	black	Supply voltage, phase, 50/60 Hz
1	5	COM	white 1	Floating status message contact, break for failure (2 A, max. 250 VAC, min. 10 mA, AC1)
1	6	NC	white 2	Floating status message contact, break for failure
2	8	0-10 V	yellow	Control input, set value 0-10 VDC, impedance 100 kΩ, SELV
2	11	10 VDC	red	Voltage output 10 VDC (+/-3%), max. 10 mA, supply voltage for external devices (e.g. potentiometer), SELV
2	12	GND	blue	Reference mass for control interface, SELV



## Charts: Air flow 50 Hz

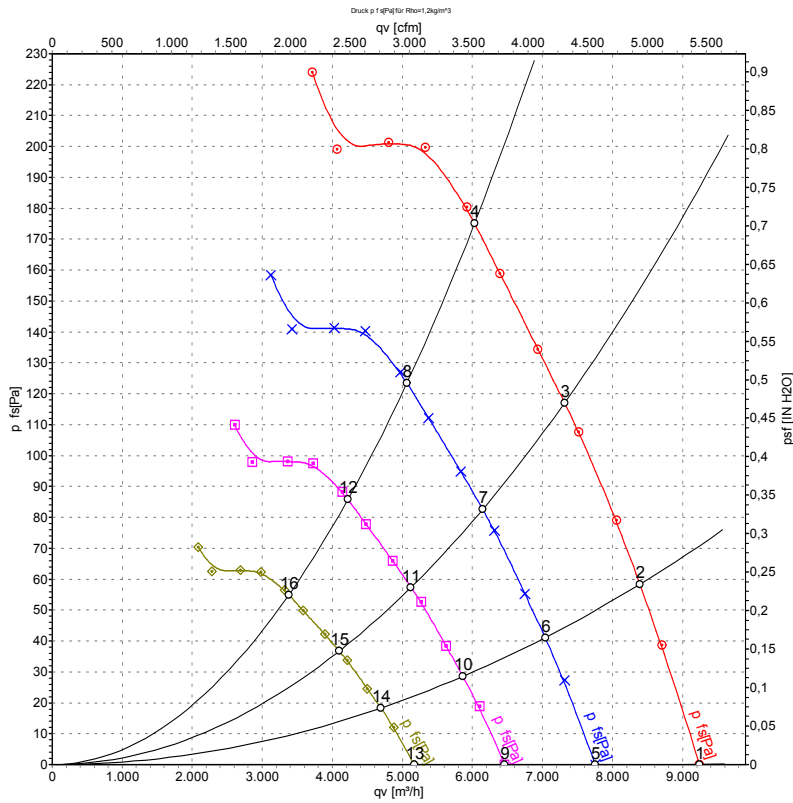

Measurement: LU-131222-1

Air performance measured as per ISO 5801 Installation category A. For detailed information on the measuring set-up, please contact ebmpapst. Suction-side noise levels: L<sub>wA</sub> measured as per ISO 13347 / L<sub>pA</sub> measured with 1m distance to fan axis. The values given are valid under the measuring conditions mentioned above and may vary according to the actual installation situation. With any deviation from the standard set-up, the specific values have to be checked and reviewed with the unit installed.

## Measured values

	U	f	n	P <sub>ed</sub>	I	LpA <sub>in</sub>	LwA <sub>in</sub>	LwA <sub>out</sub>	q <sub>v</sub>	P <sub>fs</sub>	q <sub>v</sub>	P <sub>fs</sub>
	V	Hz	min <sup>-1</sup>	W	A	dB(A)	dB(A)	dB(A)	m <sup>3</sup> /h	Pa	cfm	inH <sub>2</sub> O
1	230	50	1420	554	2.52	70	77	77	9245	0	5440	0.00
2	230	50	1420	633	2.85	67	75	75	8390	58	4940	0.23
3	230	50	1420	696	3.12	66	73	73	7315	117	4305	0.47
4	230	50	1420	750	3.40	66	74	73	6030	175	3550	0.70
5	230	50	1200	327	1.49	66	74	74	7755	0	4565	0.00
6	230	50	1200	373	1.68	64	71	71	7040	41	4145	0.16
7	230	50	1200	413	1.85	62	69	69	6145	83	3620	0.33
8	230	50	1200	443	1.97	62	70	70	5065	124	2980	0.50
9	230	50	1000	189	0.86	62	70	70	6460	0	3805	0.00
10	230	50	1000	216	0.97	60	67	67	5865	28	3455	0.11
11	230	50	1000	239	1.07	58	65	65	5125	57	3015	0.23
12	230	50	1000	256	1.14	58	66	66	4220	86	2485	0.35
13	230	50	800	97	0.44	58	65	65	5170	0	3040	0.00
14	230	50	800	111	0.50	55	62	62	4695	18	2760	0.07
15	230	50	800	122	0.55	53	60	60	4100	37	2410	0.15
16	230	50	800	131	0.59	54	61	61	3375	55	1990	0.22

U = Supply voltage · f = Frequency · n = Speed (rpm) · P<sub>ed</sub> = Power input · I = Current draw · LpA<sub>in</sub> = Sound pressure level inlet side · LwA<sub>in</sub> = Sound power level inlet side · LwA<sub>out</sub> = Sound power level outlet side  
 q<sub>v</sub> = Air flow · P<sub>fs</sub> = Pressure increase

