



A3G500-AF48-58 ebmpapst Datasheet

sales@fansco.com

www.fansco.com

Limited partnership · Headquarters Muldingen
 Amtsgericht (court of registration) Stuttgart · HRA 590344

General partner Elektrobau Muldingen GmbH · Headquarters Muldingen
 Amtsgericht (court of registration) Stuttgart · HRB 590142



Nominal data

| | | |
|--------------------------|-------------------|------------|
| Type | A3G500-AF48-58 | |
| Motor | M3G084-DF | |
| Phase | | 1~ |
| Nominal voltage | VAC | 230 |
| Nominal voltage range | VAC | 200 .. 277 |
| Frequency | Hz | 50/60 |
| Method of obtaining data | | ml |
| Speed (rpm) | min ⁻¹ | 870 |
| Power consumption | W | 180 |
| Current draw | A | 1.2 |
| Max. back pressure | Pa | 70 |
| Max. back pressure | inH2O | 0.28 |
| Min. ambient temperature | °C | -25 |
| Max. ambient temperature | °C | 65 |

ml = Max. load · me = Max. efficiency · fa = Free air · cs = Customer specification · ce = Customer equipment
 Subject to change

Data according to ErP Directive

| | | Actual | Req. 2015 |
|-----------------------------------|---|--------|-----------|
| 01 Overall efficiency η_{es} | % | 39 | 29 |
| 02 Measurement category | | A | |
| 03 Efficiency category | | Static | |
| 04 Efficiency grade N | | 50 | 40 |
| 05 Variable speed drive | | Yes | |

Data obtained at optimum efficiency level.
 The ErP data is determined using a motor-impeller combination in a standardized measurement setup.

| | | |
|-------------------------------|-------------------|------|
| 09 Power consumption P_{ed} | kW | 0.18 |
| 09 Air flow q_v | m ³ /h | 3880 |
| 09 Pressure increase p_{fs} | Pa | 58 |
| 10 Speed (rpm) n | min ⁻¹ | 880 |
| 11 Specific ratio* | | 1.00 |

* Specific ratio = $1 + p_s / 100\,000\text{ Pa}$

LU-118060



Technical description

| | |
|--|--|
| Weight | 4.4 kg |
| Fan size | 500 mm |
| Rotor surface | Painted black |
| Terminal box material | PC/ABS plastic |
| Electronics housing material | Die-cast aluminum |
| Blade material | Press-fitted sheet steel blank, sprayed with PP plastic |
| Number of blades | 5 |
| Airflow direction | "V" |
| Direction of rotation | Counterclockwise, viewed toward rotor |
| Degree of protection | IP54 |
| Insulation class | "B" |
| Moisture (F) / Environmental (H) protection class | F3-1 |
| Max. permitted ambient temp. for motor (transport/storage) | +80 °C |
| Min. permitted ambient temp. for motor (transport/storage) | -40 °C |
| Installation position | Shaft horizontal or rotor on bottom; rotor on top on request |
| Condensation drainage holes | On rotor side |
| Mode | S1 |
| Motor bearing | Ball bearing |
| Technical features | <ul style="list-style-type: none"> - Output 10 VDC, max. 10 mA - Alarm relay - Motor current limitation - Soft start - Control input 0-10 VDC / PWM - Control interface with SELV potential safely disconnected from supply - Thermal overload protection for electronics/motor |
| EMC immunity to interference | According to EN 61000-6-2 |
| EMC circuit feedback | According to EN 61000-3-2/3 |
| EMC interference emission | According to EN 61000-6-3 (household environment) |
| Touch current according to IEC 60990 (measuring circuit Fig. 4, TN system) | <= 3.5 mA |
| Electrical hookup | Via terminal box |
| Motor protection | Thermal overload protector (TOP) internally connected |
| Protection class | I (with customer connection of protective earth) |
| Conformity with standards | EN 60335-1; CE |

Product drawing

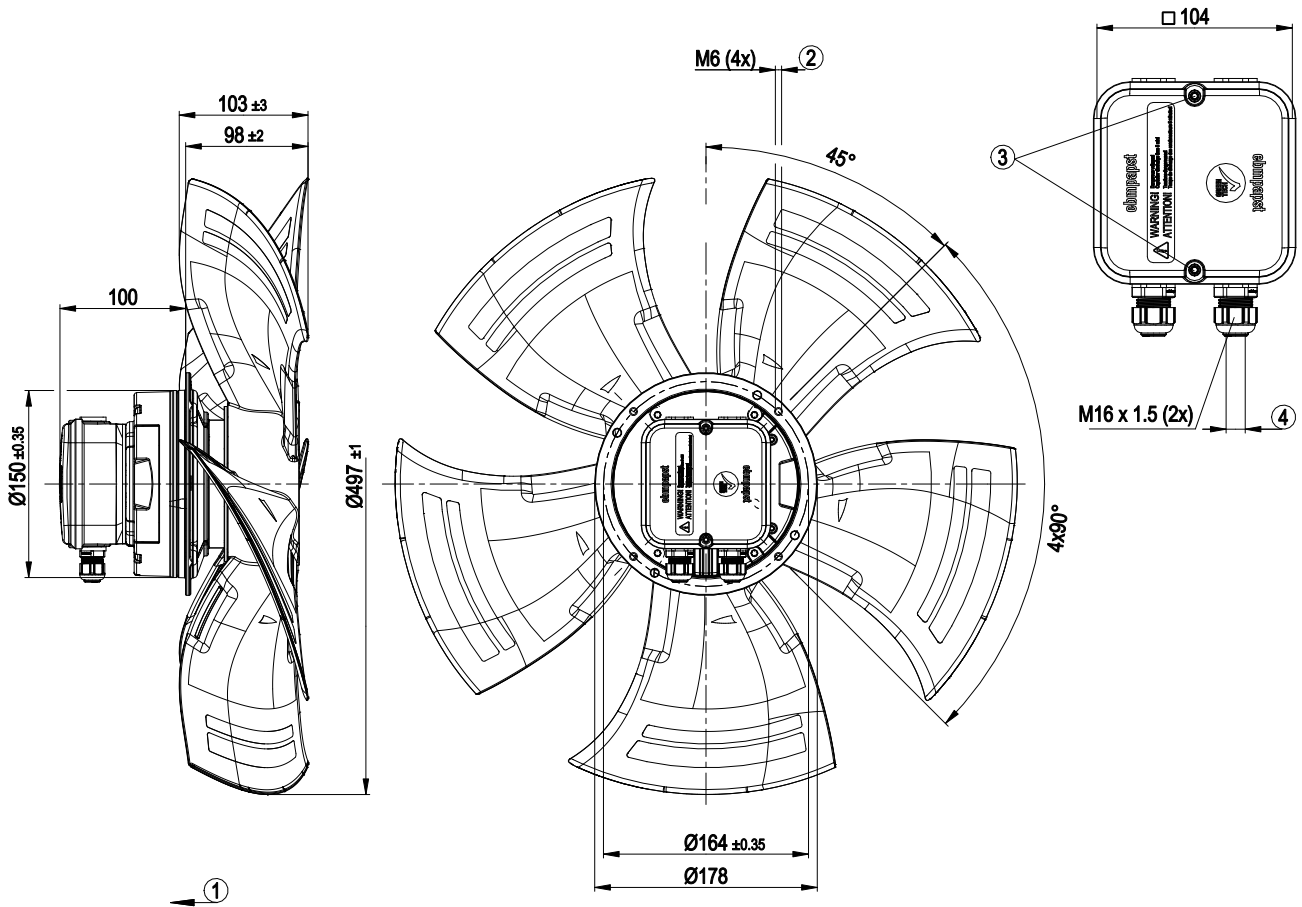

| | |
|---|--|
| 1 | Direction of air flow "V" |
| 2 | Max. clearance for screw 10 mm |
| 3 | Tightening torque 1.5 ± 0.2 Nm |
| 4 | Cable diameter min. 4 mm, max. 10 mm, tightening torque 2.5 ± 0.4 Nm |



Connection diagram

Customer circuit

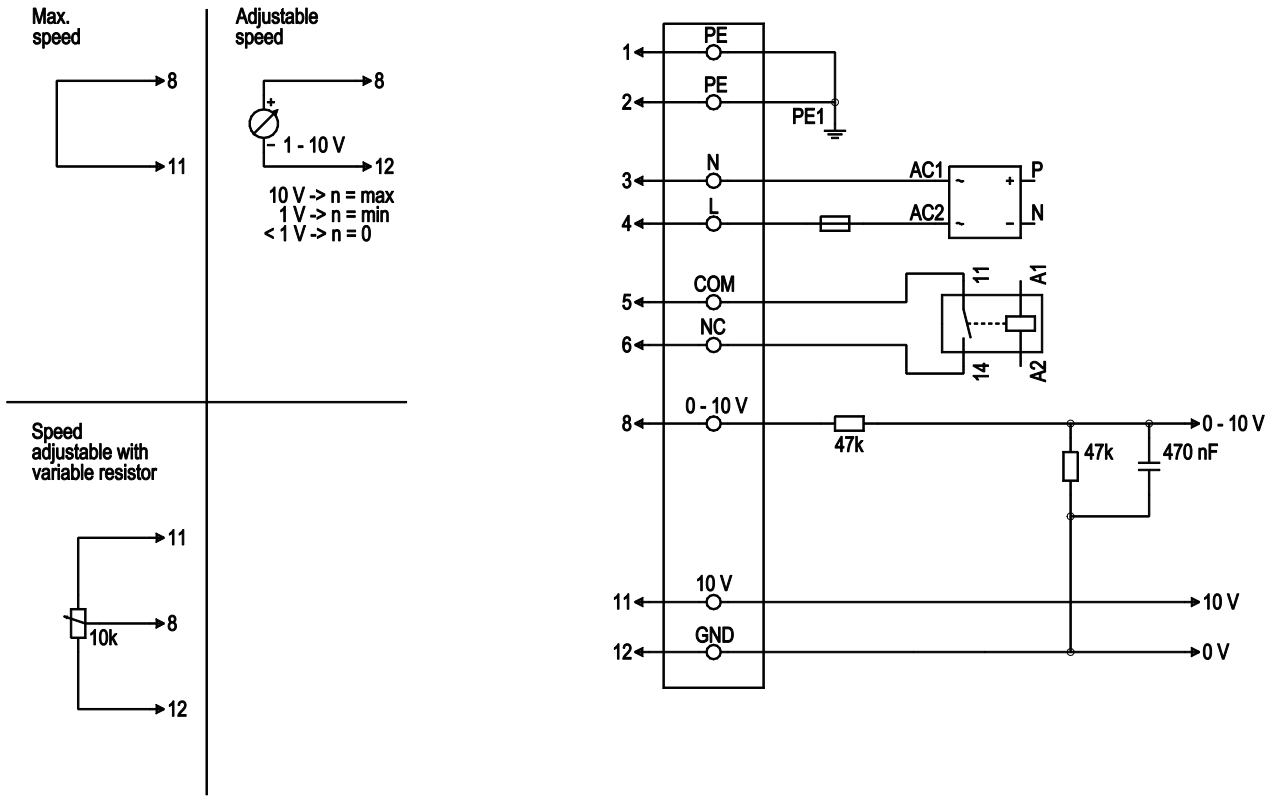

| No. | Conn. | Designation | Color | Function/assignment |
|-----|-------|-------------|--------------|--|
| 1 | 1,2 | PE | green/yellow | Protective earth |
| 1 | 3 | N | blue | Power supply, neutral conductor, 50/60 Hz |
| 1 | 4 | L | black | Power supply, phase, 50/60 Hz |
| 1 | 5 | COM | white 1 | Floating status contact, break for failure (2 A, max. 250 VAC, min. 10 mA, AC1) |
| 1 | 6 | NC | white 2 | Floating status contact, break for failure |
| 2 | 8 | 0 - 10 V | yellow | Control input, set value 0-10 VDC, impedance 100 kOhm, SELV |
| 2 | 11 | 10 VDC | red | Voltage output 10 VDC (±3%), max. 10 mA, power supply for external devices (e.g. potentiometers), SELV |
| 2 | 12 | GND | blue | Reference ground for control interface, SELV |

Curves: Air performance 50 Hz

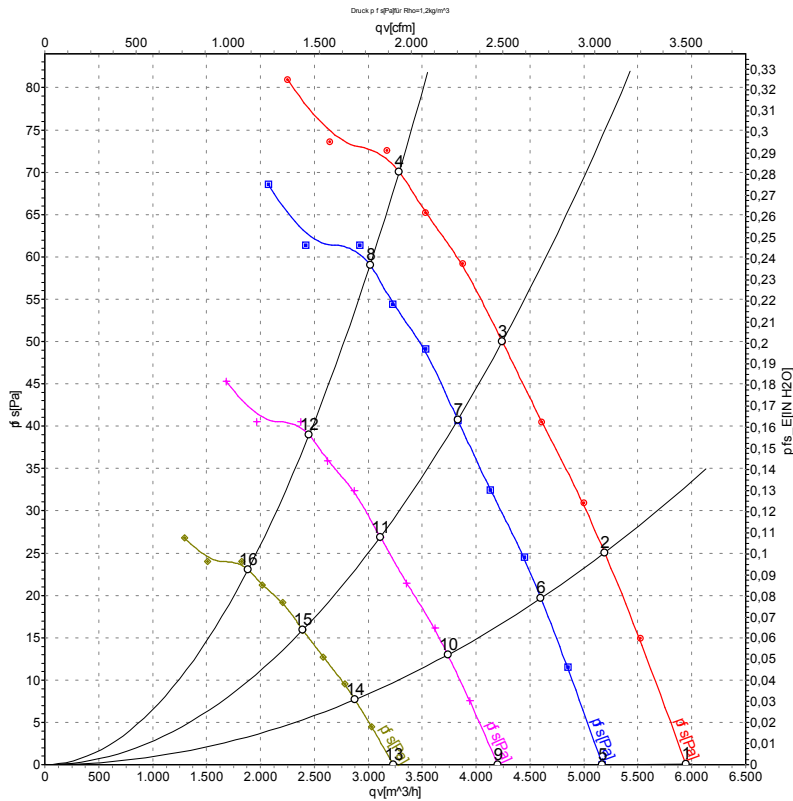

Measurement: LU-118060-1

Air performance measured according to ISO 5801 installation category A. For detailed information on the measurement setup, contact ebmpapst. Intake sound level: Sound power level according to ISO 13347 / sound pressure level measured at 1 m distance from fan axis. The values given are valid under the specified measuring conditions and may vary due to conditions of installation. For deviations from the standard configuration, the parameters have to be checked on the installed unit.

Measured values

| | U | f | n | P _{ed} | I | LpA _{in} | LwA _{in} | LwA _{out} | qv | P _{fs} | qv | P _{fs} |
|----|-----|----|-------------------|-----------------|------|-------------------|-------------------|--------------------|-------------------|-----------------|------|-----------------|
| | V | Hz | min ⁻¹ | W | A | dB(A) | dB(A) | dB(A) | m ³ /h | Pa | CFM | inH2O |
| 1 | 230 | 50 | 920 | 152 | 0.97 | 61 | 68 | 67 | 5945 | 0 | 3500 | 0.00 |
| 2 | 230 | 50 | 905 | 166 | 1.05 | 57 | 64 | 63 | 5190 | 25 | 3055 | 0.10 |
| 3 | 230 | 50 | 885 | 175 | 1.10 | 53 | 60 | 60 | 4240 | 50 | 2495 | 0.20 |
| 4 | 230 | 50 | 870 | 180 | 1.20 | 54 | 61 | 61 | 3285 | 70 | 1935 | 0.28 |
| 5 | 230 | 50 | 800 | 100 | 0.64 | 58 | 65 | 64 | 5170 | 0 | 3040 | 0.00 |
| 6 | 230 | 50 | 800 | 115 | 0.73 | 54 | 61 | 60 | 4600 | 20 | 2705 | 0.08 |
| 7 | 230 | 50 | 800 | 129 | 0.82 | 51 | 58 | 57 | 3830 | 41 | 2255 | 0.16 |
| 8 | 230 | 50 | 800 | 143 | 0.90 | 52 | 60 | 59 | 3015 | 59 | 1775 | 0.24 |
| 9 | 230 | 50 | 650 | 54 | 0.34 | 53 | 60 | 59 | 4200 | 0 | 2470 | 0.00 |
| 10 | 230 | 50 | 650 | 62 | 0.39 | 50 | 57 | 56 | 3740 | 13 | 2200 | 0.05 |
| 11 | 230 | 50 | 650 | 69 | 0.44 | 47 | 53 | 53 | 3110 | 27 | 1830 | 0.11 |
| 12 | 230 | 50 | 650 | 77 | 0.48 | 48 | 55 | 55 | 2450 | 39 | 1445 | 0.16 |
| 13 | 230 | 50 | 500 | 24 | 0.16 | 48 | 54 | 54 | 3230 | 0 | 1900 | 0.00 |
| 14 | 230 | 50 | 500 | 28 | 0.18 | 44 | 51 | 50 | 2875 | 8 | 1690 | 0.03 |
| 15 | 230 | 50 | 500 | 31 | 0.20 | 41 | 48 | 47 | 2395 | 16 | 1410 | 0.06 |
| 16 | 230 | 50 | 500 | 35 | 0.22 | 42 | 49 | 49 | 1885 | 23 | 1110 | 0.09 |

U = Power supply · f = Frequency · n = Speed (rpm) · P_{ed} = Power consumption · I = Current draw · LpA_{in} = Sound pressure level intake side · LwA_{in} = Sound power level intake side
 LwA_{out} = Sound power level outlet side · qv = Air flow · P_{fs} = Pressure increase

