



A3G500-AD01-58 ebmpapst Datasheet

sales@fansco.com

www.fansco.com

Nominal data

Type	A3G500-AD01-58	
Motor	M3G084-GF	
Phase		1~
Nominal voltage	VAC	230
Nominal voltage range	VAC	200 .. 277
Frequency	Hz	50/60
Type of data definition		ml
Speed	min ⁻¹	1100
Power input	W	360
Current draw	A	2.2
Max. back pressure	Pa	100
Min. ambient temperature	°C	-25
Max. ambient temperature	°C	55

ml = Max. load · me = Max. efficiency · fa = Running at free air · cs = Customer specs · cu = Customer unit
Subject to alterations

Data according to ErP directive

Installation category	A
Efficiency category	Static
Variable speed drive	Yes
Specific ratio*	1.00

* Specific ratio = $1 + p_b / 100\,000\text{ Pa}$

		Actual	Request 2013	Request 2015
Overall efficiency η_{es}	%	40.8	26.9	30.9
Efficiency grade N		49.9	36	40
Power input P_{ed}	kW	0.36		
Air flow q_v	m ³ /h	4585		
Pressure increase p_{fs}	Pa	106		
Speed n	min ⁻¹	1105		

Data definition with optimum efficiency.

LU-114485

The ErP data is determined using a motor-impeller combination in a standardised measurement configuration.



Technical features

Mass	5.8 kg
Size	500 mm
Surface of rotor	Coated in black
Material of terminal box	PC / ABS plastic
Material of electronics housing	Die-cast aluminium
Material of blades	Press-fitted sheet steel blank, sprayed with PP plastic
Number of blades	5
Direction of air flow	"V"
Direction of rotation	Counter-clockwise, seen on rotor
Type of protection	IP 54
Insulation class	"B"
Humidity class	F3-1
Max. permissible ambient motor temp. (transp./ storage)	+80 °C
Min. permissible ambient motor temp. (transp./storage)	-40 °C
Mounting position	Shaft horizontal or rotor on bottom; rotor on top on request
Condensate discharge holes	Rotor-side
Operation mode	S1
Motor bearing	Ball bearing
Technical features	<ul style="list-style-type: none"> - Output 10 VDC, max. 1.1 mA - Alarm relay - Motor current limit - Soft start - Control input 0-10 VDC / PWM - Control interface with SELV potential safely disconnected from the mains - Over-temperature protected electronics / motor - Line undervoltage detection
EMC interference immunity	Acc. to EN 61000-6-2
EMC harmonics	Acc. to EN 61000-3-2/3
EMC interference emission	Acc. to EN 61000-6-3 (household environment)
Touch current acc. IEC 60990 (measuring network Fig. 4, TN system)	<= 3.5 mA
Electrical leads	Via terminal box
Motor protection	Thermal overload protector (TOP) wired internally
Protection class	I (if protective earth is connected by customer)
Product conforming to standard	EN 61800-5-1; CE
Approval	EAC

Product drawing

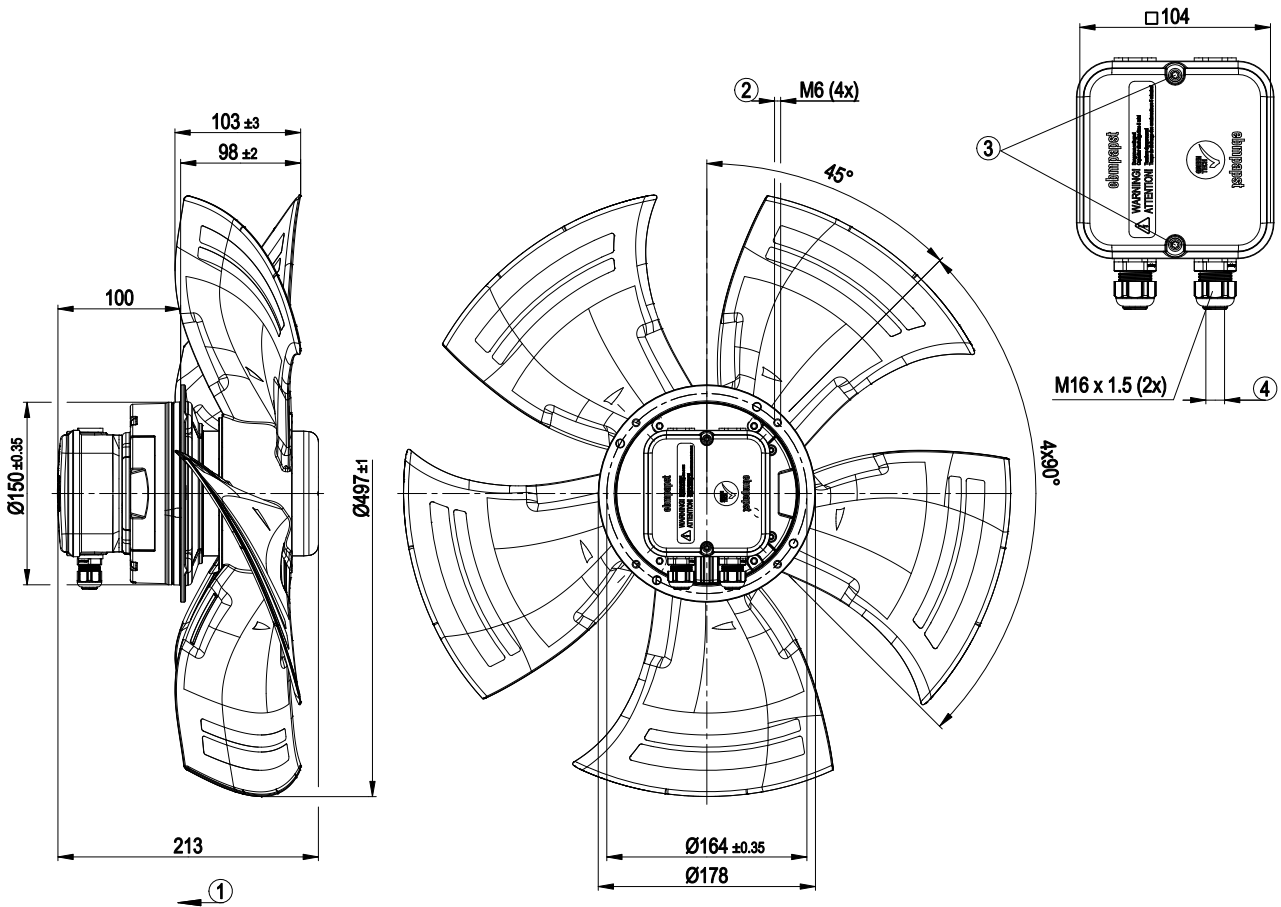

1	Direction of air flow "V"
2	Depth of screw max. 10 mm
3	Tightening torque 1.5 ± 0.2 Nm
4	Cable diameter: min. 4 mm, max. 10 mm, tightening torque: 2.5 ± 0.4 Nm



Connection screen

Customer circuit

Notes on various control possibilities and their applications

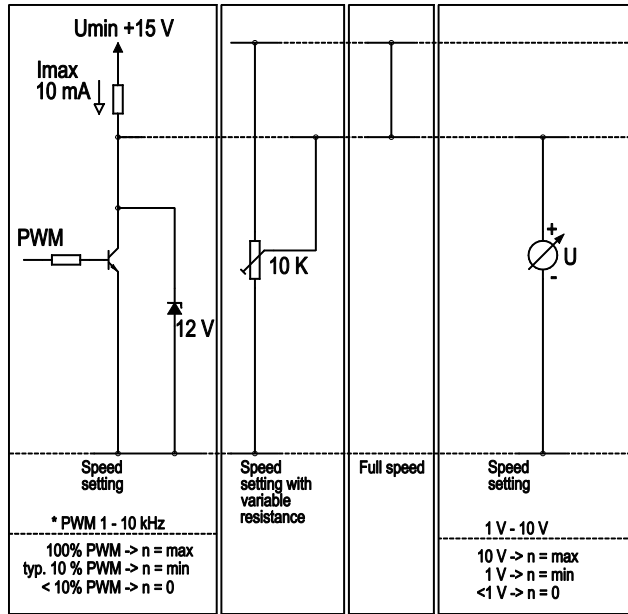

Connection

Fan / motor

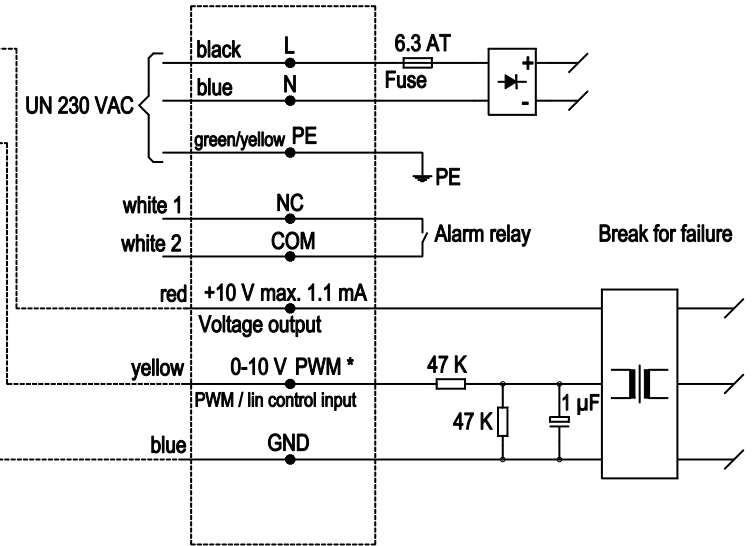

Charts: Air flow 50 Hz

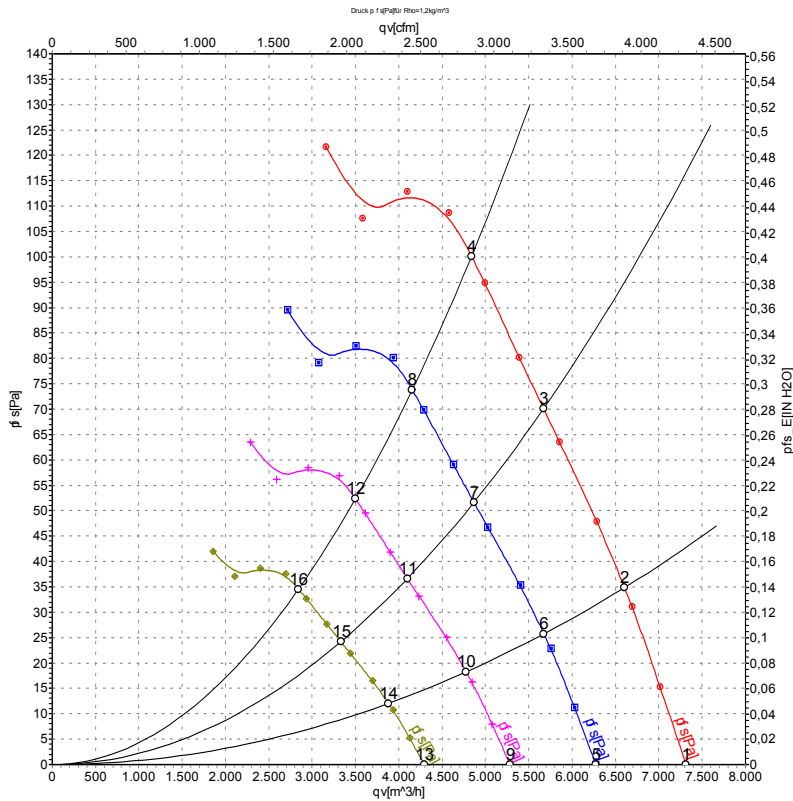

Air performance measured as per ISO 5801 Installation category A. For detailed information on the measuring set-up, please contact ebmpapst. Suction-side noise levels: LwA measured as per ISO 13347 / LpA measured with 1m distance to fan axis. The values given are valid under the measuring conditions mentioned above and may vary according to the actual installation situation. With any deviation from the standard set-up, the specific values have to be checked and reviewed with the unit installed.

Measured values

	U	f	n	P _{ed}	I	LpA _{in}	LwA _{in}	LwA _{out}	qv	p _{fs}
	V	Hz	min ⁻¹	W	A	dB(A)	dB(A)	dB(A)	m ³ /h	Pa
1	230	50	1100	264	1.62	61	68	68	7315	0
2	230	50	1100	301	1.82	60	66	66	6605	35
3	230	50	1100	336	2.02	59	65	65	5670	70
4	230	50	1100	360	2.20	60	66	66	4840	100
5	230	50	950	166	1.02	58	65	64	6270	0
6	230	50	950	191	1.15	56	63	62	5675	26
7	230	50	950	213	1.27	55	62	62	4870	52
8	230	50	950	228	1.37	56	63	62	4155	74
9	230	50	800	99	0.61	54	61	61	5280	0
10	230	50	800	114	0.69	53	59	59	4775	18
11	230	50	800	127	0.76	52	58	58	4100	37
12	230	50	800	136	0.82	53	59	59	3500	52
13	230	50	650	53	0.33	50	56	56	4290	0
14	230	50	650	61	0.37	48	55	54	3880	12
15	230	50	650	68	0.41	47	54	53	3330	24
16	230	50	650	73	0.44	48	55	54	2840	34

U = Supply voltage · f = Frequency · n = Speed · P_{ed} = Power input · I = Current draw · LpA_{in} = Sound pressure level inlet side · LwA_{in} = Sound power level inlet side · LwA_{out} = Sound power level outlet side
 qv = Air flow · p_{fs} = Pressure increase

