

A3G450-BK14-P2

EC axial fan

sickle-shaped blades (S series)

for rail applications



A3G450-BK14-P2 ebmpapst Datasheet

sales@fansco.com

www.fansco.com

Limited partnership · Headquarters Muldingen

Amtsgericht (court of registration) Stuttgart · HRA 590344

General partner Elektrobau Muldingen GmbH · Headquarters Muldingen

Amtsgericht (court of registration) Stuttgart · HRB 590142

Nominal data

Type	A3G450-BK14-P2	
Motor	M3G084-DF	
Nominal voltage	VDC	110
Nominal voltage range	VDC	77 .. 138
Frequency	Hz	DC
Method of obtaining data		ml
Speed (rpm)	min ⁻¹	1300
Power consumption	W	340
Current draw	A	3.1
Max. back pressure	Pa	120
Max. back pressure	in. wg	0.48
Min. ambient temperature	°C	-40
Max. ambient temperature	°C	60

ml = Max. load · me = Max. efficiency · fa = Free air · cs = Customer specification · ce = Customer equipment
Subject to change



Technical description

Weight	4.7 kg
Fan size	450 mm
Rotor surface	Painted black
Electronics housing material	Die-cast aluminum, painted black
Impeller material	PA plastic UL94 V0
Number of blades	5
Airflow direction	"V"
Direction of rotation	Counterclockwise, viewed toward rotor
Degree of protection	IP55
Insulation class	"F"
Moisture (F) / Environmental (H) protection class	H3
Max. permitted ambient temp. for motor (transport/storage)	+80 °C
Min. permitted ambient temp. for motor (transport/storage)	-40 °C
Installation position	Shaft horizontal or rotor on top; rotor on bottom on request
Mode	S1
Motor bearing	Ball bearing; (sealed)
Technical features	<ul style="list-style-type: none"> - Output 10 VDC, max. 10 mA - Operation and alarm display - Alarm relay - Motor current limitation - RS-485 MODBUS-RTU - Soft start - EEPROM write cycles: 100,000 maximum - Control input 0-10 VDC / PWM - Control interface with SELV potential safely disconnected from the mains - Overvoltage detection - Thermal overload protection for electronics/motor - Line undervoltage detection
EMC regulations	According to EN 50121-3-2
Motor protection	Thermal overload protector (TOP) internally connected
With cable	Lateral
Protection class	I (with customer connection of protective earth)
Conformity with standards	EN 15085-1, CPC3: 2007; EN 45545-2, HL3: 2013; EN 50155: 2008; EN 61373, Cat. 1B: 2010
Approval	EAC
Comment	<p>If voltage (e.g. 230 VAC) is passed through the alarm relay, the SELV signal wires lose their property of reinforced insulation, meaning they then have only basic insulation</p> <p>The SELV property (reinforced insulation) is not lost when voltages of up to 110 VDC are passed through the alarm relay.</p>

EC axial fan

sickle-shaped blades (S series)

for rail applications

Product drawing

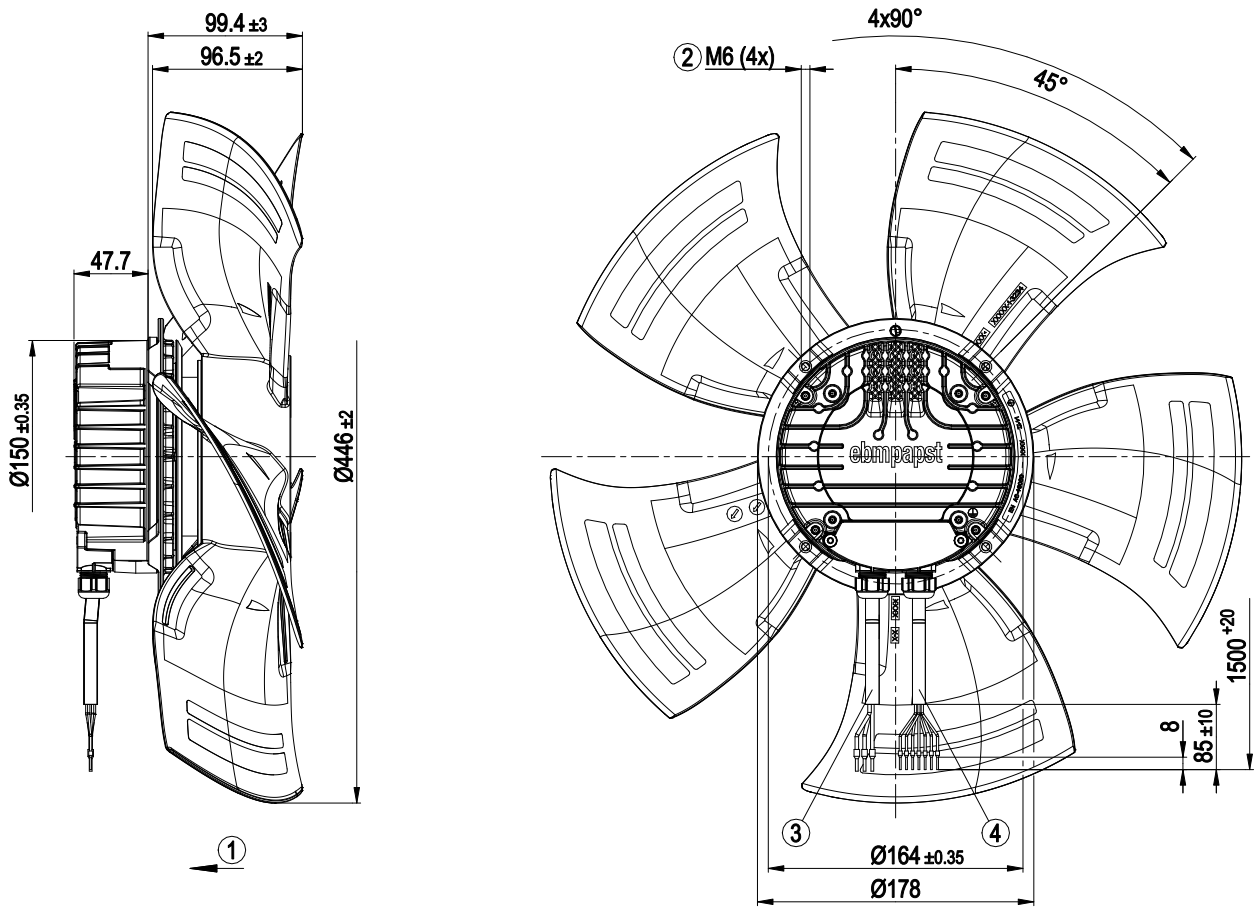

1	Airflow direction "V"
2	Max. clearance for screw 16 mm
3	Cable halogen-free, BETAtans® 3 GKW flex, 4G 1.5 mm ² , 3x crimped ferrules, 1 lead not brought out
4	Cable halogen-free, BETAtans® 3 GKW flex, 7x 0.5 mm ² , 7x crimped ferrules



EC axial fan

sickle-shaped blades (S series)

for rail applications

Connection diagram

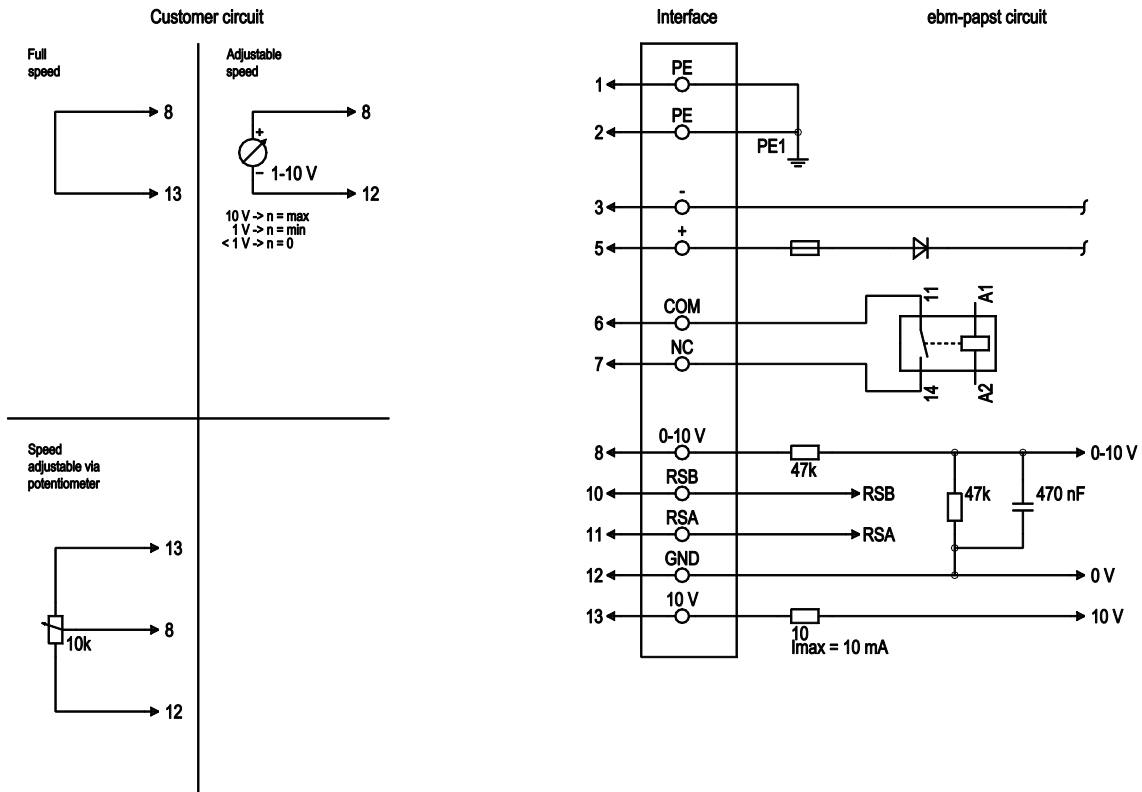

No.	Conn.	Designation	Color	Function/assignment
1	1, 2	PE	green/yellow	Protective earth
1	3	-	black	Power supply, GND, voltage range see nameplate
1	5	+	brown	Power supply, voltage range see nameplate
2	6	COM	gray	Status relay, floating status contact, break for failure, contact rating 250 VAC / max. 2 A (AC1) / min. 1 mA / 5 V, basic insulation on supply side and on control interface side
2	7	NC	orange	Status relay, floating status contact, common connection, contact rating 250 VAC / max. 2 A (AC1) / min. 1 mA / 5 V, basic insulation on supply side and on control interface side
2	8	0-10 V	yellow	Analog input 1, set value: 0-10 V, R _i = 100 kΩ, adjustable curve; SELV
2	10	RSB	brown	RS485 interface for MODBUS, RSB; SELV
2	11	RSA	white	RS485 interface for MODBUS, RSA; SELV
2	12	GND	blue	Reference ground for control interface; SELV
2	13	+10 V	red	Fixed voltage output 10 VDC, +10 V ±3%, max. 10 mA, short-circuit-proof power supply for external devices (e.g. pot); SELV



EC axial fan

sickle-shaped blades (S series)
for rail applications

Curves: Air performance

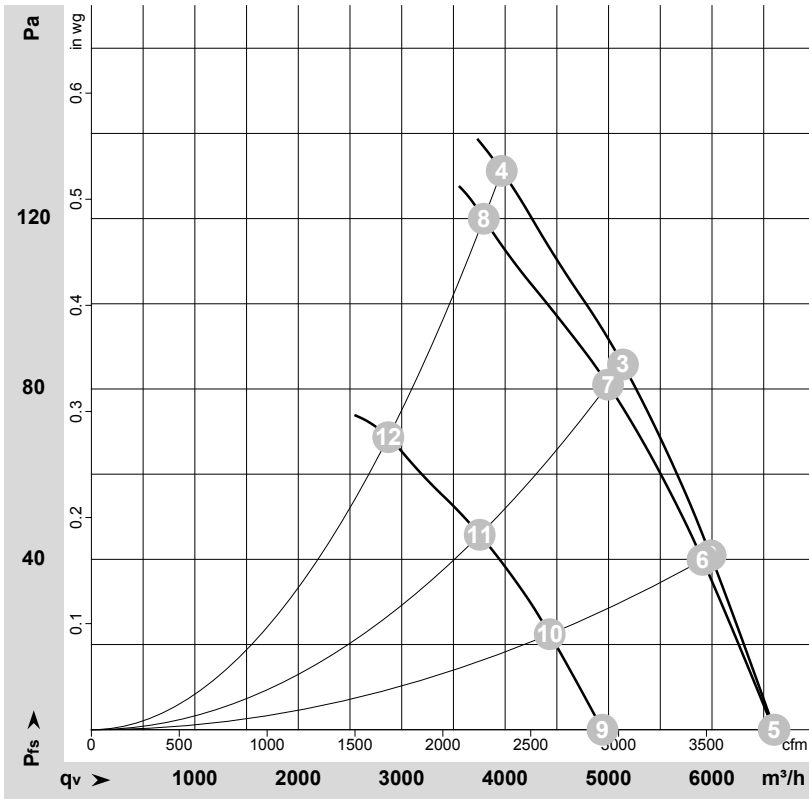

$\rho = 1.15 \text{ kg/m}^3 \pm 2 \%$

Measurement: LU-164405-1
Measurement: LU-164083-1
Measurement: LU-164404-1

Air performance measured according to ISO 5801 installation category A. For detailed information on the measurement setup, contact ebmpapst. Intake sound level: Sound power level according to ISO 13347 / sound pressure level measured at 1 m distance from fan axis. The values given are valid under the specified measuring conditions and may vary due to conditions of installation. For deviations from the standard configuration, the parameters have to be checked on the installed unit.

Measured values

	Wired	U	n	P _{ed}	I	LpA _{in}	LwA _{in}	q _v	P _{fs}	q _v	P _{fs}
		V	min ⁻¹	W	A	dB(A)	dB(A)	m ³ /h	Pa	cfm	in. wg
1	Y	138	1350	298	2.16			6605	0	3890	0.00
2	Y	138	1350	333	2.41			5985	42	3525	0.17
3	Y	138	1350	365	2.64			5140	86	3025	0.35
4	Y	138	1350	395	2.86			3965	132	2335	0.53
5	Y	110	1350	297	2.69	65	60	6595	0	3885	0.00
6	Y	110	1330	317	2.88	62	62	5910	40	3480	0.16
7	Y	110	1310	332	3.01	60	66	4995	80	2940	0.32
8	Y	110	1300	340	3.10	61	68	3795	120	2230	0.48
9	Y	77	1015	126	1.63			4940	0	2910	0.00
10	Y	77	1000	135	1.75			4430	23	2610	0.09
11	Y	77	990	142	1.84			3755	46	2210	0.18
12	Y	77	980	147	1.90			2870	69	1690	0.28

Wired = Wiring · U = Power supply · n = Speed (rpm) · P_{ed} = Power consumption · I = Current draw · LpA_{in} = Sound pressure level intake side · LwA_{in} = Sound power level intake side
q_v = Air flow · P_{fs} = Pressure increase

