

A3G450-AK65-02 ebmpapst Datasheet

sales@fansco.com

www.fansco.com

Limited partnership · Headquarters Mulfingen

Amtsgericht (court of registration) Stuttgart · HRA 590344

General partner Elektrobau Mulfingen GmbH · Headquarters Mulfingen

Amtsgericht (court of registration) Stuttgart · HRB 590142

## Nominal data

Type	A3G450-AK65-02	
Motor	M3G074-CF	
Phase		1~
Nominal voltage	VAC	230
Frequency	Hz	50/60
Method of obtaining data		me
Speed (rpm)	min <sup>-1</sup>	835
Power consumption	W	105
Current draw	A	0.8
Min. ambient temperature	°C	-25
Max. ambient temperature	°C	60

ml = Max. load · me = Max. efficiency · fa = Free air · cs = Customer specification · ce = Customer equipment  
Subject to change



## Technical description

Weight	2.7 kg
Fan size	450 mm
Rotor surface	Painted black
Electronics housing material	Die-cast aluminum
Blade material	Press-fitted sheet steel blank, sprayed with PP plastic
Number of blades	5
Airflow direction	"A"
Degree of protection	IP44; installation- and position-dependent as per EN 60034-5
Insulation class	"B"
Moisture (F) / Environmental (H) protection class	F3-1
Max. permitted ambient temp. for motor (transport/storage)	+ 80 °C
Min. permitted ambient temp. for motor (transport/storage)	- 40 °C
Installation position	Shaft horizontal or rotor on bottom; rotor on top on request
Condensation drainage holes	On rotor side
Mode	S1
Motor bearing	Ball bearing
Technical features	<ul style="list-style-type: none"> <li>- Control input 0-10 VDC / PWM</li> <li>- Output 10 VDC, max. 1.1 mA</li> <li>- Tach output</li> <li>- Thermal overload protection for motor</li> <li>- Soft start</li> </ul>
EMC immunity to interference	According to EN 61000-6-2 (industrial environment)
EMC circuit feedback	According to EN 61000-3-2/3
EMC interference emission	According to EN 61000-6-3 (household environment)
Touch current according to IEC 60990 (measuring circuit Fig. 4, TN system)	<= 3.5 mA
Motor protection	Thermal overload protector (TOP) internally connected
With cable	Variable
Protection class	I (with customer connection of protective earth)
Conformity with standards	CE

Product drawing

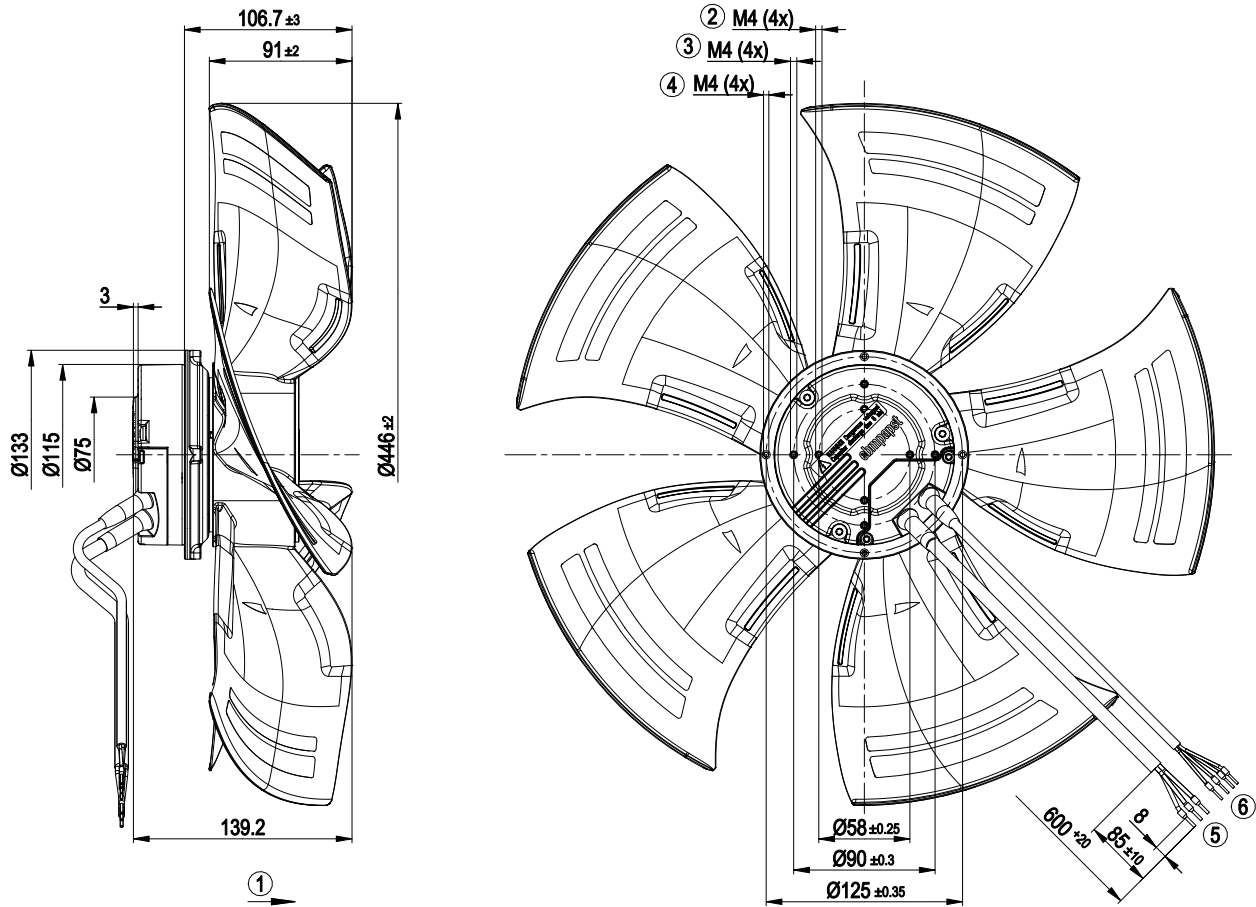

1	Direction of air flow "A"
2	Tapping hole ready for self-tapping M4 screw, max. clearance for screw 8 mm
3	Tapping hole ready for self-tapping M4 screw, max. clearance for screw 6 mm
4	Clearance for screw 8 - 10 mm
5	Cable PVC AWG 18, 3x crimped ferrules
6	Cable PVC AWG 22, 4x crimped ferrules

## Connection diagram

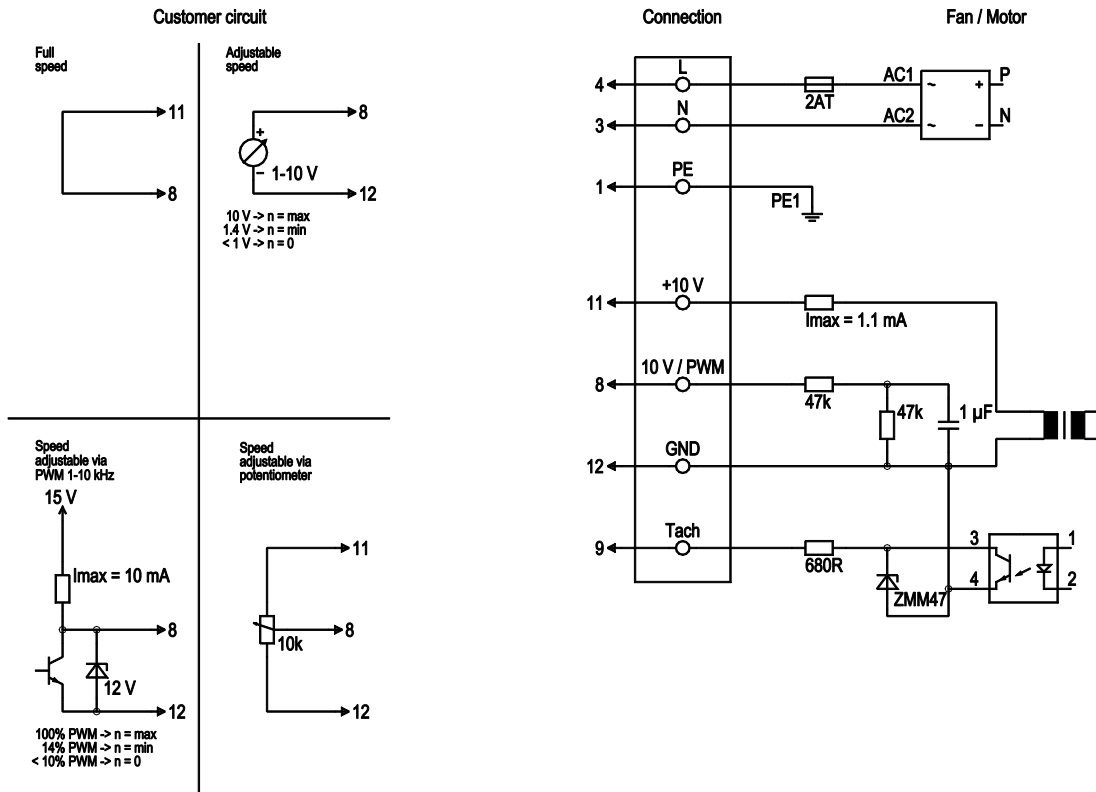

No.	Conn.	Designation	Color	Function/assignment
	4	L	black	Power supply 230 VAC, 50-60 Hz, see nameplate for voltage range
	3	N	blue	Neutral conductor
	1	PE	green/yellow	Protective earth
	8	0-10 V PWM	yellow	Control input 0-10 V or PWM, electrically isolated
	9	Tach	white	Tach output: open collector, 1 pulse per revolution, electrically isolated
	11	10V / max 1.1 mA	red	Voltage output 10 V/max. 1.1 mA, electrically isolated
	12	GND	blue	GND connection for control interface

## Curves: Air performance 50 Hz

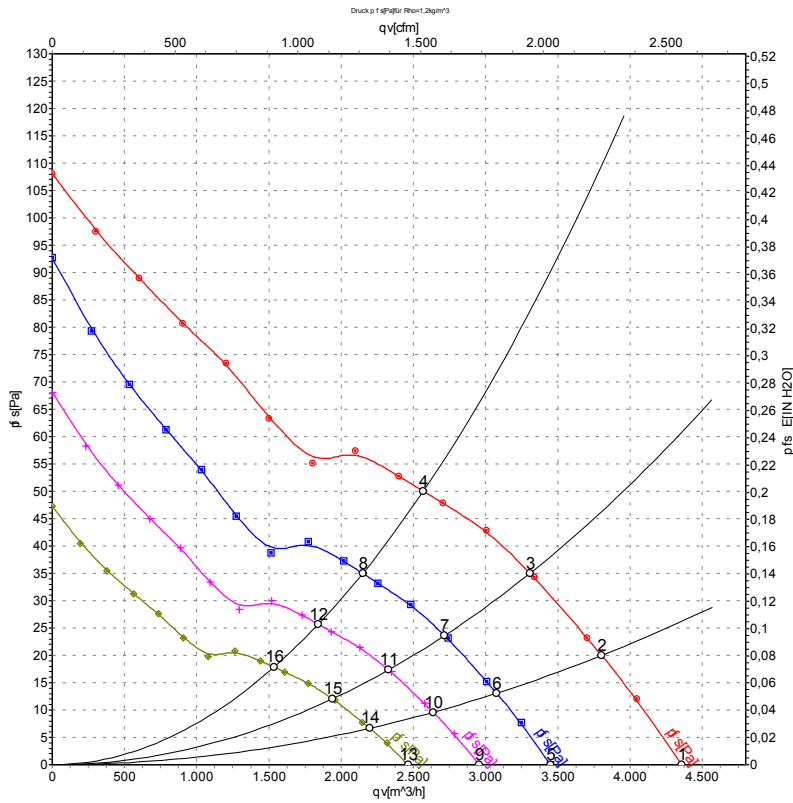

Measurement: LU-122753-1

Air performance measured according to ISO 5801 installation category A. For detailed information on the measurement setup, contact ebmpapst. Intake sound level: Sound power level according to ISO 13347 / sound pressure level measured at 1 m distance from fan axis. The values given are valid under the specified measuring conditions and may vary due to conditions of installation. For deviations from the standard configuration, the parameters have to be checked on the installed unit.

## Measured values

	U	f	n	P <sub>ed</sub>	I	LpA <sub>in</sub>	LwA <sub>in</sub>	qv	p <sub>fs</sub>	qv	p <sub>fs</sub>
	V	Hz	min <sup>-1</sup>	W	A	dB(A)	dB(A)	m <sup>3</sup> /h	Pa	CFM	inH2O
1	230	50	885	90	0.68	56	62	4355	0	2565	0.00
2	230	50	865	96	0.73	54	60	3800	20	2240	0.08
3	230	50	850	100	0.76	51	58	3305	35	1945	0.14
4	230	50	835	105	0.80	50	57	2570	50	1510	0.20
5	230	50	700	45	0.34	51	57	3450	0	2030	0.00
6	230	50	700	51	0.39	49	55	3075	13	1810	0.05
7	230	50	700	56	0.42	47	53	2715	24	1600	0.10
8	230	50	700	62	0.47	46	53	2150	35	1265	0.14
9	230	50	600	28	0.21	48	54	2955	0	1740	0.00
10	230	50	600	32	0.24	46	52	2635	10	1550	0.04
11	230	50	600	35	0.27	44	50	2325	17	1370	0.07
12	230	50	600	39	0.29	43	50	1840	26	1085	0.10
13	230	50	500	16	0.12	44	50	2465	0	1450	0.00
14	230	50	500	19	0.14	42	48	2195	7	1295	0.03
15	230	50	500	20	0.15	40	46	1940	12	1140	0.05
16	230	50	500	22	0.17	39	46	1535	18	905	0.07

U = Power supply · f = Frequency · n = Speed (rpm) · P<sub>ed</sub> = Power consumption · I = Current draw · LpA<sub>in</sub> = Sound pressure level intake side · LwA<sub>in</sub> = Sound power level intake side  
 qv = Air flow · p<sub>fs</sub> = Pressure increase

