

A3G450-AC28-52 ebmpapst Datasheet

sales@fansco.com

www.fansco.com

Limited partnership · Headquarters Mulfingen

Amtsgericht (court of registration) Stuttgart · HRA 590344

General partner Elektrobau Mulfingen GmbH · Headquarters Mulfingen

Amtsgericht (court of registration) Stuttgart · HRB 590142



Nominal data

Type	A3G450-AC28-52	
Motor	M3G084-FA	
Phase		1~
Nominal voltage	VAC	230
Nominal voltage range	VAC	200 .. 277
Frequency	Hz	50/60
Method of obtaining data		ml
Speed (rpm)	min ⁻¹	1300
Power consumption	W	345
Current draw	A	2.2
Max. back pressure	Pa	125
Max. back pressure	inH ₂ O	0.5
Min. ambient temperature	°C	-25
Max. ambient temperature	°C	60

ml = Max. load · me = Max. efficiency · fa = Free air · cs = Customer specification · ce = Customer equipment
Subject to change

Data according to ErP Directive

		Actual	Req. 2015			
01 Overall efficiency η_{es}	%	42.6	30.7	09 Power consumption P_{ed}	kW	0.34
02 Measurement category		A		09 Air flow q_v	m ³ /h	4005
03 Efficiency category		Static		09 Pressure increase p_{fs}	Pa	118
04 Efficiency grade N		51.9	40	10 Speed (rpm) n	min ⁻¹	1305
05 Variable speed drive		Yes		11 Specific ratio*		1.00

Data obtained at optimum efficiency level.

The ErP data is determined using a motor-impeller combination in a standardized measurement setup.

* Specific ratio = $1 + p_s / 100\,000\text{ Pa}$

LU-124620



Technical description

Weight	4.8 kg
Fan size	450 mm
Rotor surface	Painted black
Electronics housing material	Die-cast aluminum
Blade material	Press-fitted sheet steel blank, sprayed with PP plastic
Number of blades	5
Airflow direction	"A"
Direction of rotation	Clockwise, viewed toward rotor
Degree of protection	IP54
Insulation class	"B"
Moisture (F) / Environmental (H) protection class	F3-1
Max. permitted ambient temp. for motor (transport/storage)	80 °C
Min. permitted ambient temp. for motor (transport/storage)	-40 °C
Installation position	Shaft horizontal or rotor on bottom; rotor on top on request
Condensation drainage holes	On rotor side
Mode	S1
Motor bearing	Ball bearing
Technical features	<ul style="list-style-type: none"> - Control input 0-10 VDC / PWM - Output 10 VDC, max. 1.1 mA - Thermal overload protection for electronics/motor - Alarm relay - Line undervoltage detection - Motor current limitation - Soft start
EMC immunity to interference	According to EN 61000-6-2 (industrial environment)
EMC circuit feedback	According to EN 61000-3-2/3
EMC interference emission	According to EN 61000-6-3 (household environment)
Touch current according to IEC 60990 (measuring circuit Fig. 4, TN system)	<= 3.5 mA
Motor protection	Thermal overload protector (TOP) internally connected
With cable	Variable
Protection class	I (with customer connection of protective earth)
Conformity with standards	EN 61800-5-1; CE
Approval	CCC; EAC; UL 2111; CSA C22.2 No. 77

Product drawing

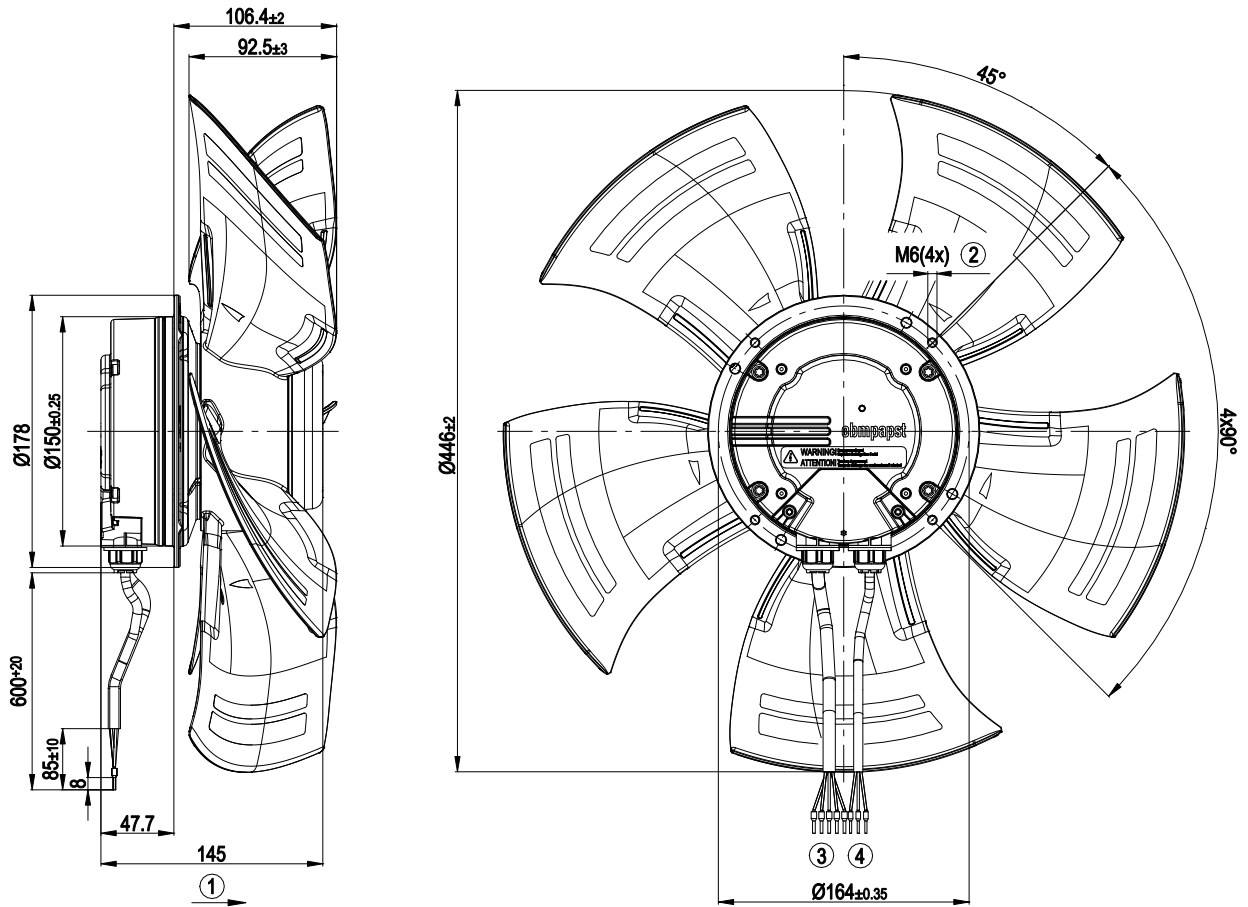

1	Direction of air flow "A"
2	Clearance for screw 8 - 10 mm
3	Cable AWG18, 5 x crimped ferrules
4	Cable AWG22, 3 x crimped ferrules

Connection diagram

Customer circuit

Application notes for various control options

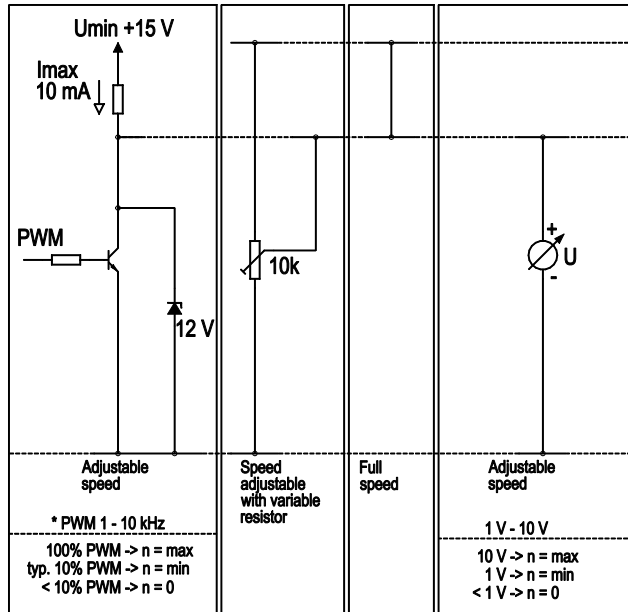

Connection

Fan / Motor

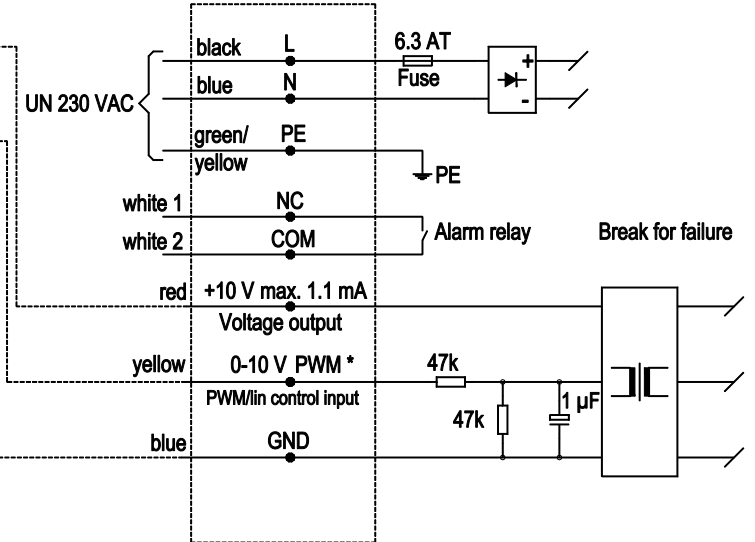

Curves: Air performance 50 Hz

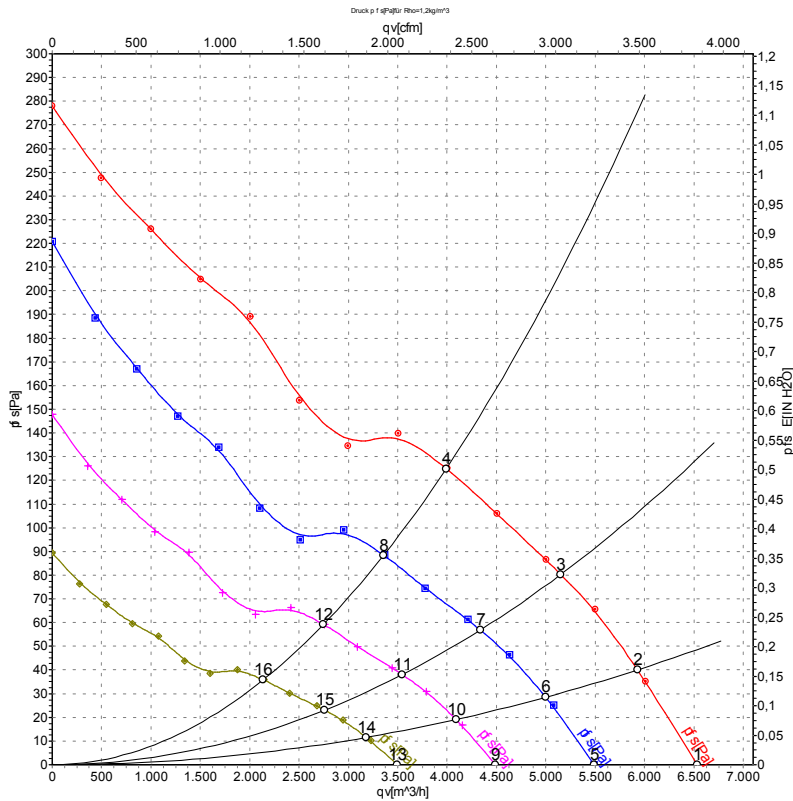

Measurement: LU-124620-1

Air performance measured according to ISO 5801 installation category A. For detailed information on the measurement setup, contact ebmpapst. Intake sound level: Sound power level according to ISO 13347 / sound pressure level measured at 1 m distance from fan axis. The values given are valid under the specified measuring conditions and may vary due to conditions of installation. For deviations from the standard configuration, the parameters have to be checked on the installed unit.

Measured values

	U	f	n	P _{ed}	I	LpA _{in}	LwA _{in}	LwA _{out}	qv	P _{fs}	qv	P _{fs}
	V	Hz	min ⁻¹	W	A	dB(A)	dB(A)	dB(A)	m ³ /h	Pa	CFM	inH ₂ O
1	230	50	1300	270	1.72	65	71	72	6535	0	3845	0.00
2	230	50	1300	298	1.91	62	68	69	5925	40	3490	0.16
3	230	50	1300	326	2.07	60	65	67	5150	80	3030	0.32
4	230	50	1300	345	2.20	61	67	68	3990	125	2350	0.50
5	230	50	1100	160	1.02	61	67	68	5490	0	3230	0.00
6	230	50	1100	179	1.15	58	64	65	4995	29	2940	0.12
7	230	50	1100	194	1.23	56	62	63	4335	57	2550	0.23
8	230	50	1100	205	1.30	57	63	64	3360	89	1975	0.36
9	230	50	900	87	0.56	57	63	64	4490	0	2645	0.00
10	230	50	900	98	0.63	54	60	61	4090	19	2405	0.08
11	230	50	900	106	0.68	52	57	59	3545	38	2085	0.15
12	230	50	900	112	0.71	53	59	60	2745	60	1615	0.24
13	230	50	700	41	0.26	51	57	58	3490	0	2055	0.00
14	230	50	700	46	0.30	48	55	56	3180	12	1870	0.05
15	230	50	700	50	0.32	46	52	53	2760	23	1625	0.09
16	230	50	700	53	0.34	47	54	54	2135	36	1260	0.14

U = Power supply · f = Frequency · n = Speed (rpm) · P_{ed} = Power consumption · I = Current draw · LpA_{in} = Sound pressure level intake side · LwA_{in} = Sound power level intake side
LwA_{out} = Sound power level outlet side · qv = Air flow · p_{fs} = Pressure increase

