

A3G400-AA14-A9 ebmpapst Datasheet

sales@fansco.com

www.fansco.com

Limited partnership · Headquarters Muldingen

Amtsgericht (court of registration) Stuttgart · HRA 590344

General partner Elektrobau Muldingen GmbH · Headquarters Muldingen

Amtsgericht (court of registration) Stuttgart · HRB 590142



## Nominal data

Type	A3G400-AA14-A9	
Motor	M3G084-FA	
Phase		1~
Nominal voltage	VAC	230
Nominal voltage range	VAC	200 .. 277
Frequency	Hz	50/60
Method of obtaining data		ml
Speed (rpm)	min <sup>-1</sup>	1650
Power consumption	W	435
Current draw	A	1.9
Max. back pressure	Pa	180
Max. back pressure	inH <sub>2</sub> O	0.72
Min. ambient temperature	°C	-25
Max. ambient temperature	°C	60

ml = Max. load · me = Max. efficiency · fa = Free air · cs = Customer specification · ce = Customer equipment  
Subject to change

## Data according to ErP Directive

		Actual	Req. 2015			
01 Overall efficiency $\eta_{es}$	%	42.5	31.2	09 Power consumption $P_{ed}$	kW	0.4
02 Measurement category		A		09 Air flow $q_v$	m <sup>3</sup> /h	3505
03 Efficiency category		Static		09 Pressure increase $p_{fs}$	Pa	161
04 Efficiency grade N		51.3	40	10 Speed (rpm) n	min <sup>-1</sup>	1650
05 Variable speed drive		Yes		11 Specific ratio*		1.00

Data obtained at optimum efficiency level.

The ErP data is determined using a motor-impeller combination in a standardized measurement setup.

\* Specific ratio =  $1 + p_s / 100\,000\text{ Pa}$ 

LU-119465



### Technical description

Weight	5.4 kg
Fan size	400 mm
Rotor surface	Painted black
Electronics housing material	Die-cast aluminum
Blade material	Sheet steel, painted black
Number of blades	5
Airflow direction	"V"
Direction of rotation	Counterclockwise, viewed toward rotor
Degree of protection	IP54
Insulation class	"B"
Moisture (F) / Environmental (H) protection class	F3-1
Max. permitted ambient temp. for motor (transport/storage)	+80 °C
Min. permitted ambient temp. for motor (transport/storage)	-40 °C
Installation position	Shaft horizontal or rotor on bottom; rotor on top on request
Condensation drainage holes	On rotor side
Mode	S1
Motor bearing	Ball bearing
Technical features	<ul style="list-style-type: none"> <li>- Tach output</li> <li>- Motor current limitation</li> <li>- PFC, active</li> <li>- Soft start</li> <li>- Control input 0-10 VDC / PWM</li> <li>- Control interface with SELV potential safely disconnected from the mains</li> <li>- Thermal overload protection for electronics/motor</li> <li>- Line undervoltage / phase failure detection</li> </ul>
Touch current according to IEC 60990 (measuring circuit Fig. 4, TN system)	<= 3.5 mA
Electrical hookup	With plug
Motor protection	Thermal overload protector (TOP) internally connected
With cable	Variable
Protection class	I (with customer connection of protective earth)
Conformity with standards	EN 61800-5-1
Approval	CCC; UL 2111; CSA C22.2 No. 77

# EC axial fan

sickle-shaped blades (S series)

## Product drawing

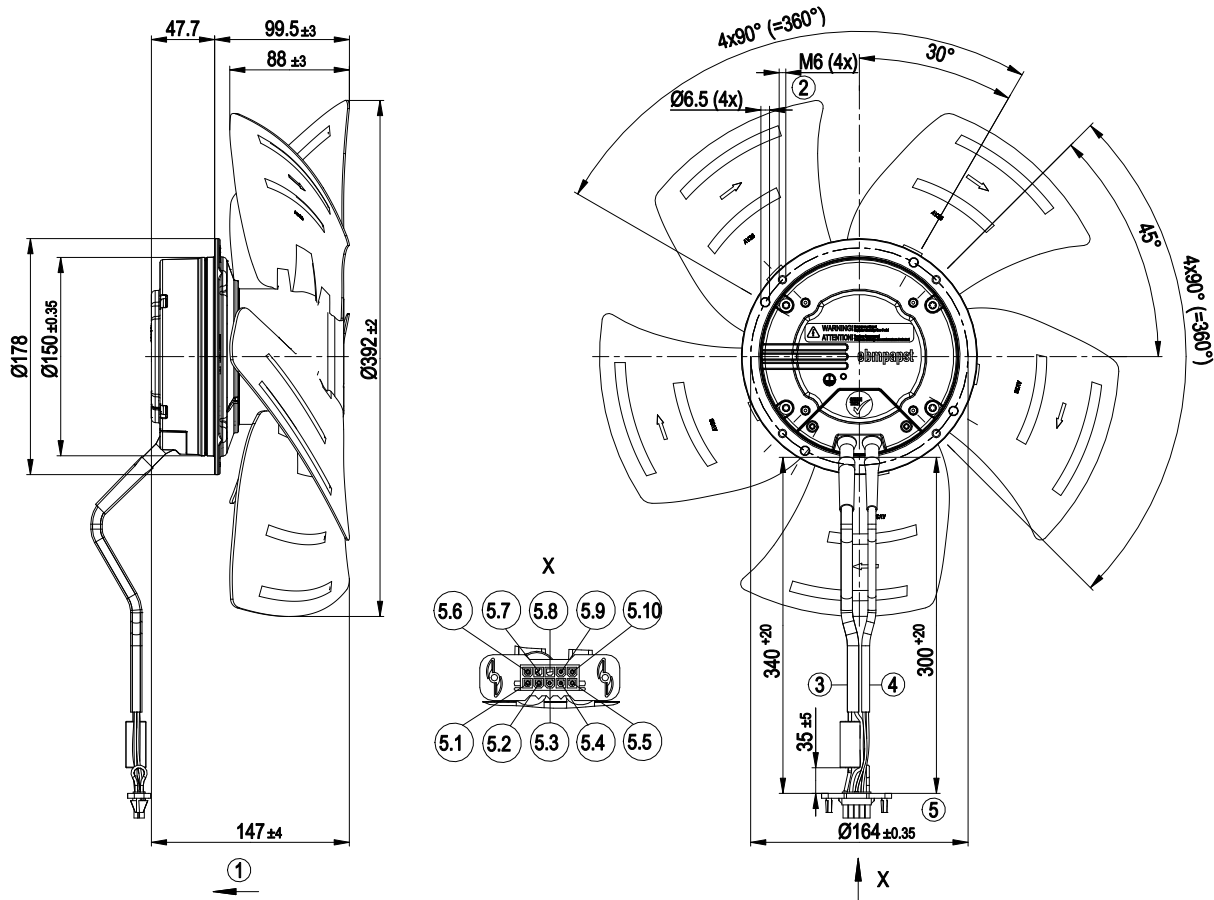

1	Direction of air flow "V"
2	Max. clearance for screw 10 mm
3	Cable PVC AWG18, 3x socket Molex 39-00-0428 crimped
4	Cable PVC AWG22, 3x socket Molex 39-00-0428 crimped
5	Connector housing Molex 15-06-0101
5.1	L (black)
5.2	PE (green-yellow)
5.3	GND (blue)
5.4	0-10 V PWM; PWM/Lin control input (yellow)
5.5	Bridge to 5.10 (orange)
5.6	N (blue)
5.7	not used
5.8	not used
5.9	Speed monitoring, 1 pulse per revolution (white)
5.10	Bridge to 5.5 (orange)



## Connection diagram

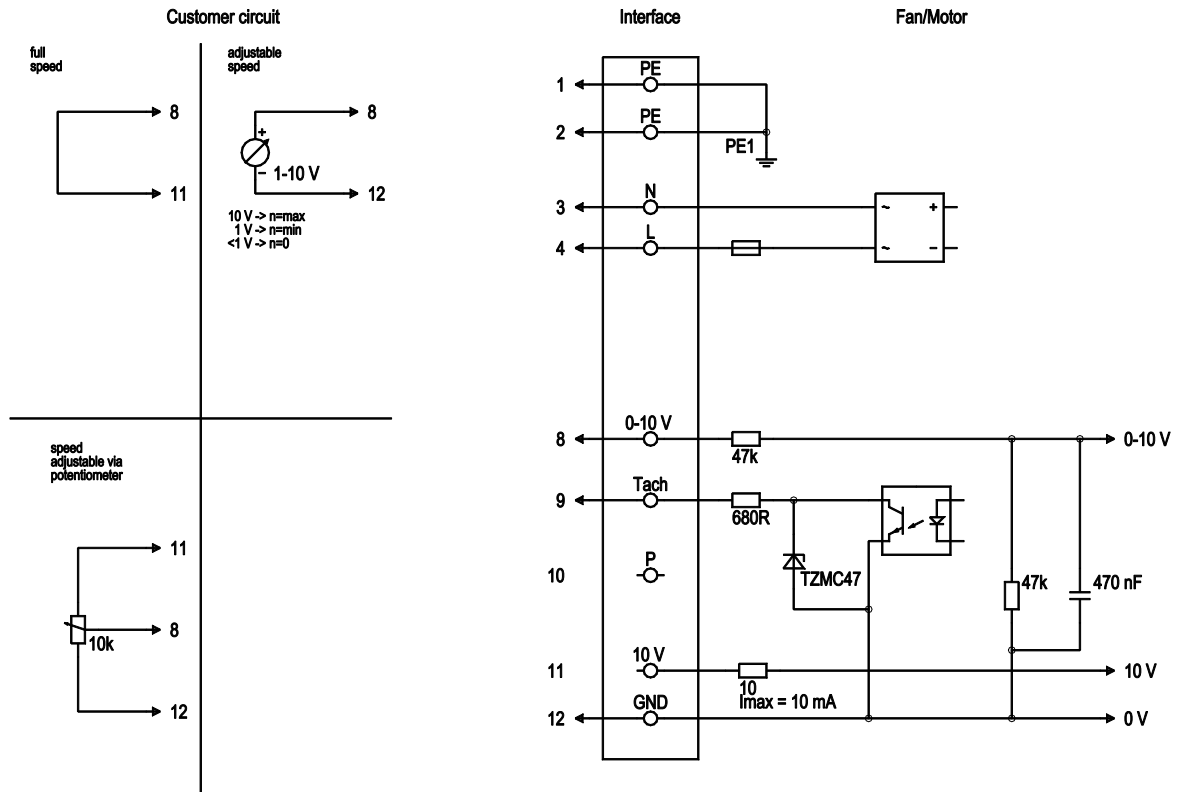

No.	Conn.	Designation	Color	Function/assignment
1	1, 2	PE	green/yellow	Protective earth
1	3	N	blue	Power supply, neutral conductor, 50/60 Hz
1	4	L	black	Power supply, phase, 50/60 Hz
2	8	0-10V	yellow	Control input, set value 0-10 VDC, impedance 100 kohms, SELV
2	9	Tach	white	Tach output: Open collector, 1 pulse per revolution, electrically isolated, Isink max. 10 mA
2	10	P		not used
2	11	10 VDC		not used
2	12	GND	blue	Reference ground for control interface, SELV

## Curves: Air performance 50 Hz

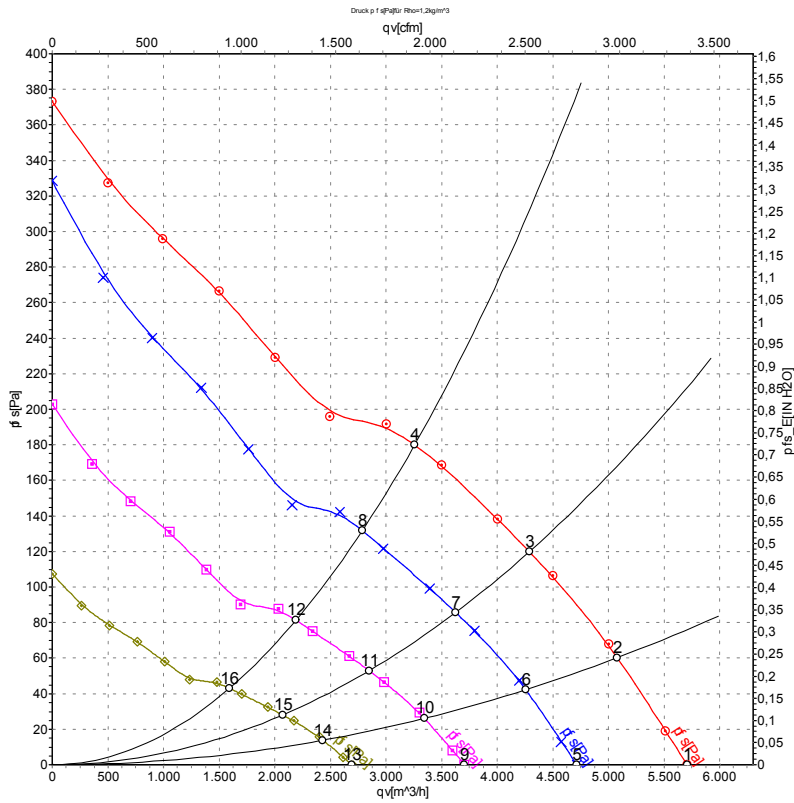

Measurement: LU-119465-1

Air performance measured according to ISO 5801 installation category A. For detailed information on the measurement setup, contact ebmpapst. Intake sound level: Sound power level according to ISO 13347 / sound pressure level measured at 1 m distance from fan axis. The values given are valid under the specified measuring conditions and may vary due to conditions of installation. For deviations from the standard configuration, the parameters have to be checked on the installed unit.

## Measured values

	U	f	n	P <sub>ed</sub>	I	qv	p <sub>fs</sub>	qv	p <sub>fs</sub>
	V	Hz	min <sup>-1</sup>	W	A	m <sup>3</sup> /h	Pa	CFM	inH2O
1	230	50	1695	355	1.56	5705	0	3360	0.00
2	230	50	1670	383	1.68	5080	60	2990	0.24
3	230	50	1655	400	1.76	4290	120	2525	0.48
4	230	50	1650	435	1.90	3255	180	1915	0.72
5	230	50	1400	200	0.88	4715	0	2775	0.00
6	230	50	1400	225	0.99	4255	43	2505	0.17
7	230	50	1400	242	1.06	3625	86	2135	0.35
8	230	50	1400	264	1.16	2785	132	1640	0.53
9	230	50	1100	97	0.43	3705	0	2180	0.00
10	230	50	1100	109	0.48	3345	26	1970	0.10
11	230	50	1100	117	0.52	2850	53	1675	0.21
12	230	50	1100	128	0.56	2190	81	1290	0.33
13	230	50	800	37	0.16	2695	0	1585	0.00
14	230	50	800	42	0.19	2430	14	1430	0.06
15	230	50	800	45	0.20	2070	28	1220	0.11
16	230	50	800	49	0.22	1595	43	940	0.17

U = Power supply · f = Frequency · n = Speed (rpm) · P<sub>ed</sub> = Power consumption · I = Current draw · qv = Air flow · p<sub>fs</sub> = Pressure increase

