

A3G350-AP01-15 ebmpapst Datasheet

sales@fansco.com

www.fansco.com

Limited partnership · Headquarters Mulfingen

Amtsgericht (court of registration) Stuttgart · HRA 590344

General partner Elektrobau Mulfingen GmbH · Headquarters Mulfingen

Amtsgericht (court of registration) Stuttgart · HRB 590142

Nominal data

Type	A3G350-AP01-15	
Motor	M3G074-DF	
Phase		1~
Nominal voltage	VAC	230
Nominal voltage range	VAC	200 .. 240
Frequency	Hz	50/60
Method of obtaining data		ml
Speed (rpm)	min ⁻¹	1500
Power consumption	W	165
Current draw	A	1.35
Min. ambient temperature	°C	-25
Max. ambient temperature	°C	60

ml = Max. load · me = Max. efficiency · fa = Free air · cs = Customer specification · ce = Customer equipment
Subject to change

Data according to Commission Regulation (EU) 327/2011 (EN 17166)

		Actual	Req. 2015			
01 Overall efficiency η_{es}	%	46	28.8	09 Power consumption P_{ed}	kW	0.16
02 Measurement category		A		09 Air flow q_v	m ³ /h	2405
03 Efficiency category		Static		09 Pressure increase p_{fs}	Pa	101
04 Efficiency grade N		57.2	40	10 Speed (rpm) n	min ⁻¹	1515
05 Variable speed drive		Yes		11 Specific ratio [*]		1.00

Data obtained at optimum efficiency level.

The ErP data is determined using a motor-impeller combination in a standardized measurement setup.

^{*} Specific ratio = $1 + p_{fs} / 100\,000\text{ Pa}$

LU-177333



Technical description

Weight	2.2 kg
Size	350 mm
Motor size	74
Rotor surface	Painted black
Blade material	PP plastic
Number of blades	5
Airflow direction	V
Direction of rotation	Counterclockwise, viewed toward rotor
Degree of protection	IP54
Insulation class	"B"
Moisture (F) / Environmental (H) protection class	H2
Max. permitted ambient temp. for motor (transport/storage)	+ 80 °C
Min. permitted ambient temp. for motor (transport/storage)	- 40 °C
Installation position	Shaft horizontal or rotor on bottom; rotor on top on request
Condensation drainage holes	None, open rotor
Cooling hole/opening	On rotor side
Mode	S1
Motor bearing	Ball bearing
Technical features	<ul style="list-style-type: none"> - Output 10 VDC, max. 10 mA - Tach output - Power limiter - Motor current limitation - Soft start - Control input 0-10 VDC / PWM - Control interface with SELV potential safely disconnected from the mains - Overvoltage detection - Thermal overload protection for electronics/motor - Line undervoltage detection
EMC immunity to interference	According to EN 61000-6-2 (industrial environment)
EMC interference emission	According to EN 61000-6-4 (industrial environment)
Touch current according to IEC 60990 (measuring circuit Fig. 4, TN system)	<= 3.5 mA
Motor protection	Electronic motor protection
With cable	Variable
Protection class	I (with customer connection of protective earth)
Conformity with standards	EN 60034-1; EN 60204-1; EN 60335-1; CE

Product drawing

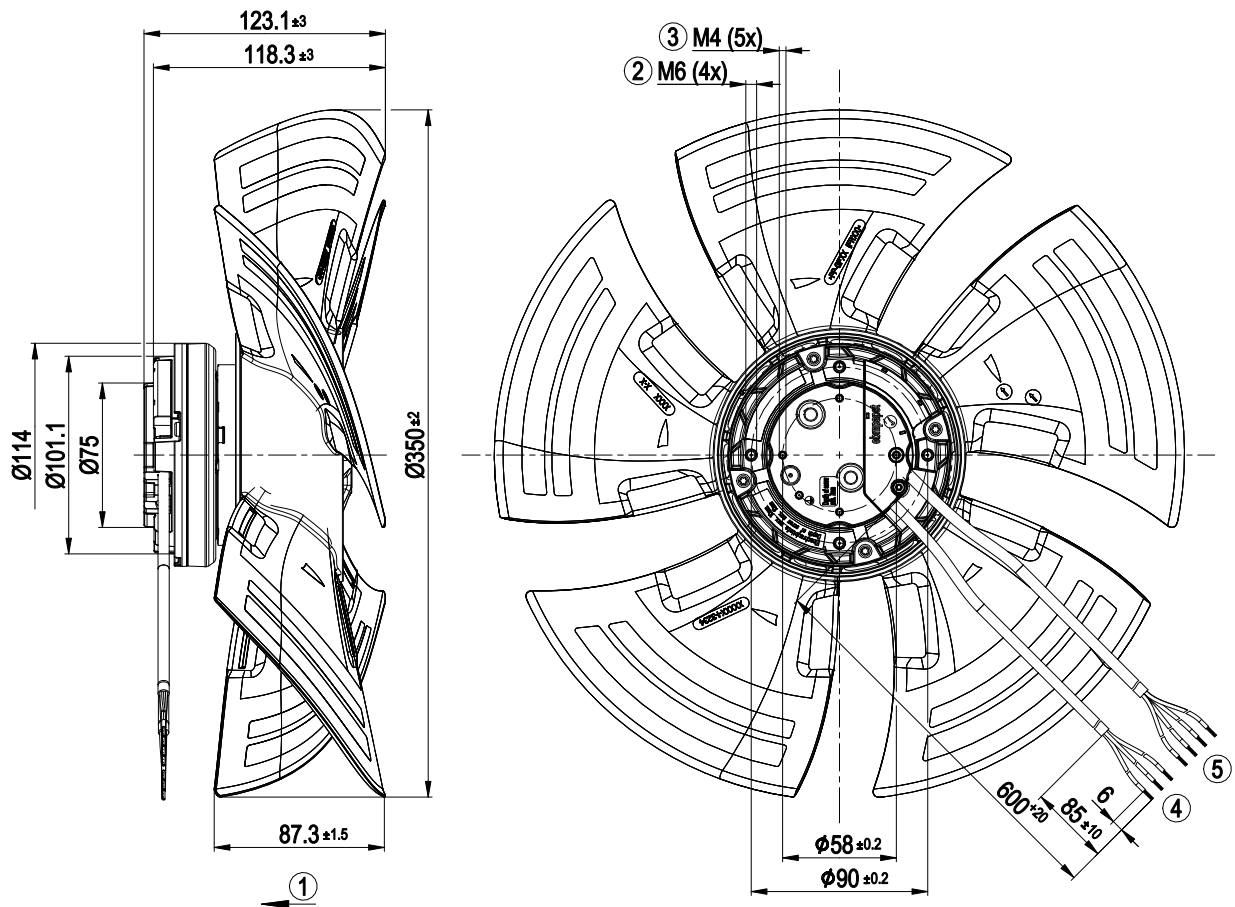

1	Airflow direction "V"
2	Max. clearance for screw 10 mm
3	Max. clearance for screw 5 mm
4	Cable PVC AWG20 3x splice
5	Cable PVC AWG22 4x splice

Connection diagram

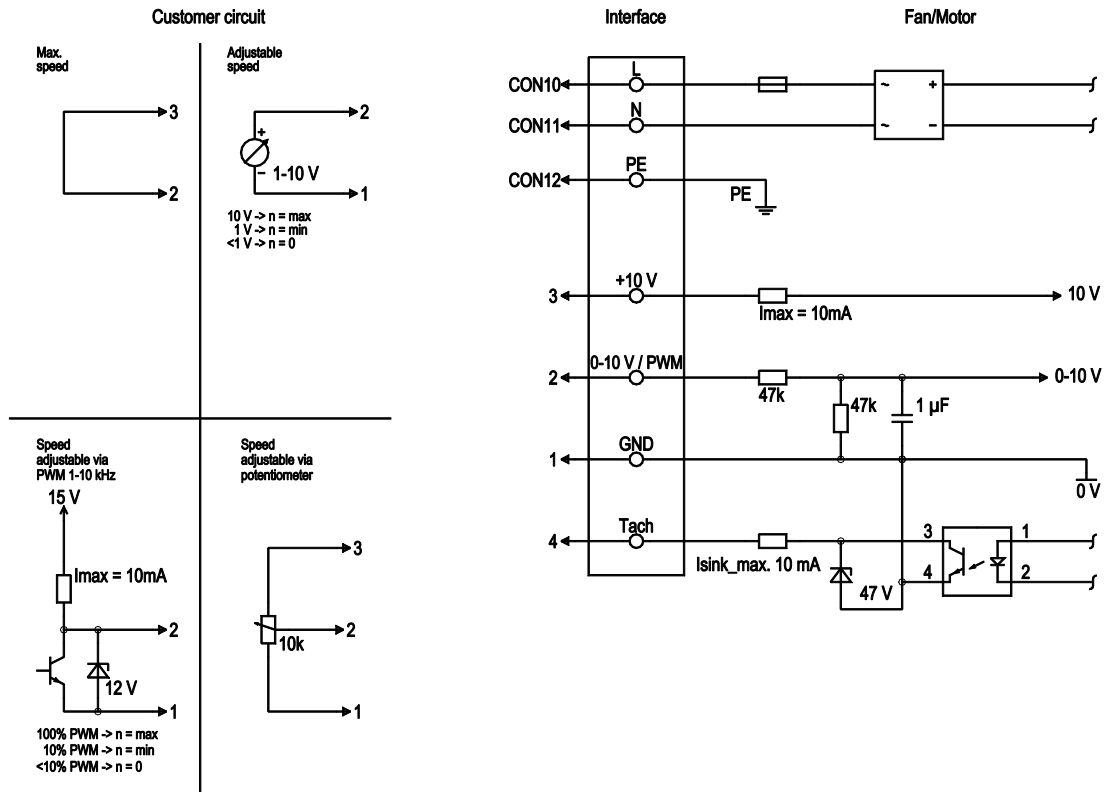

No.	Conn.	Designation	Color	Function/assignment
	CON10	L	black	Supply connection, power supply, phase, see nameplate for voltage range
	CON11	N	blue	Supply connection, power supply, neutral conductor, see nameplate for voltage range
	CON12	PE	green/yellow	Ground connection
	2	0- 10V PWM	yellow	0-10 V / PWM control input, R _i =100 kΩ, SELV
	4	Tach	white	Tach output, open collector, 1 pulse per revolution, I _{sink_max} = 10 mA, SELV
	3	+10 V	red	Fixed voltage output 10 VDC +/-3 %, I _{max} . 10 mA, short-circuit-proof, power supply for ext. devices (e.g. pot), SELV
	1	GND	blue	Reference ground for control interface, SELV

Curves: Air performance 50 Hz

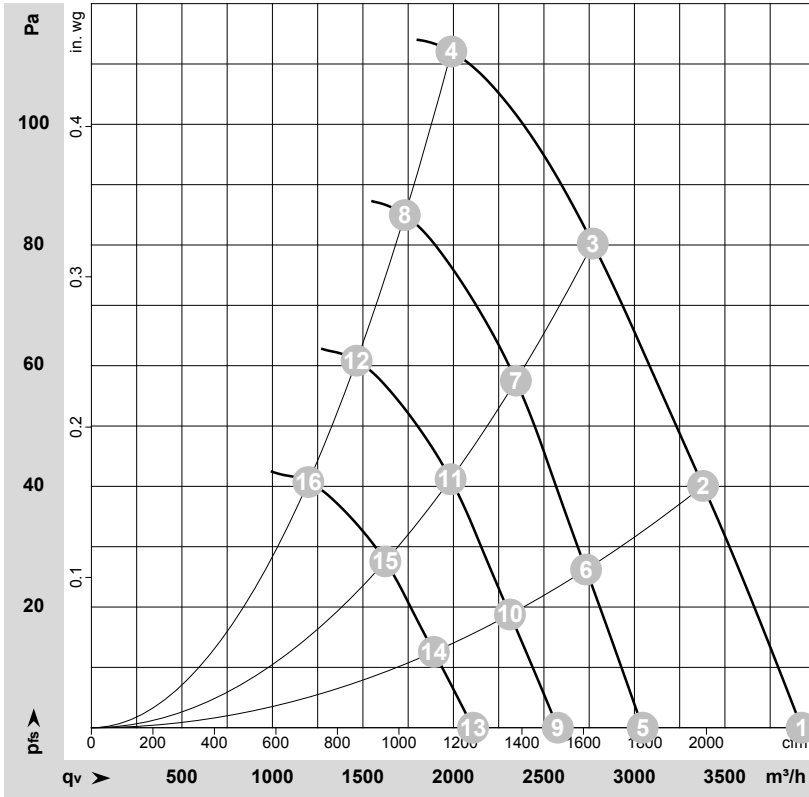

$\rho = 1.15 \text{ kg/m}^3 \pm 2 \%$

Measurement: LU-177333-1

Air performance measured according to ISO 5801 installation category A. For detailed information on the measurement setup, contact ebmpapst. Intake sound level: Sound power level according to ISO 13347 / sound pressure level measured at 1 m distance from fan axis. The values given are valid under the specified measuring conditions and may vary due to conditions of installation. For deviations from the standard configuration, the parameters have to be checked on the installed unit.

Measured values

	Wired	U	f	n	P _{ed}	I	LpA _{in}	LwA _{in}	q _v	P _{fs}	q _v	P _{fs}
		V	Hz	min ⁻¹	W	A	dB(A)	dB(A)	m ³ /h	Pa	cfm	in. wg
1	1~	230	50	1675	165	1.35	66	73	3925	0	2310	0.00
2	1~	230	50	1610	165	1.35	62	69	3380	40	1990	0.16
3	1~	230	50	1535	165	1.35	59	66	2770	80	1630	0.32
4	1~	230	50	1500	165	1.35	62	70	1990	115	1170	0.46
5	1~	230	50	1300	75	0.61	59	66	3045	0	1795	0.00
6	1~	230	50	1300	87	0.71	57	64	2735	26	1610	0.10
7	1~	230	50	1300	98	0.80	55	62	2345	58	1380	0.23
8	1~	230	50	1300	109	0.89	58	66	1730	86	1020	0.35
9	1~	230	50	1100	45	0.37	55	62	2575	0	1515	0.00
10	1~	230	50	1100	53	0.43	53	60	2310	19	1360	0.08
11	1~	230	50	1100	60	0.49	51	58	1985	42	1170	0.17
12	1~	230	50	1100	66	0.54	54	62	1465	62	860	0.25
13	1~	230	50	900	25	0.20	50	57	2110	0	1240	0.00
14	1~	230	50	900	29	0.23	48	55	1890	13	1115	0.05
15	1~	230	50	900	33	0.27	46	53	1625	28	955	0.11
16	1~	230	50	900	36	0.30	49	57	1200	41	705	0.16

Wired = Wiring · U = Voltage · f = Frequency · n = Speed (rpm) · P_{ed} = Power consumption · I = Current draw · LpA_{in} = Sound pressure level intake side · LwA_{in} = Sound power level intake side
 q_v = Air flow · P_{fs} = Pressure increase

