

A3G350-AN01-12 ebmpapst Datasheet

sales@fansco.com

www.fansco.com

Limited partnership · Headquarters Muldingen

Amtsgericht (court of registration) Stuttgart · HRA 590344

General partner Elektrobau Muldingen GmbH · Headquarters Muldingen

Amtsgericht (court of registration) Stuttgart · HRB 590142

Nominal data

Type	A3G350-AN01-12		
Motor	M3G074-CF		
Phase		1~	1~
Nominal voltage	VAC	230	230
Nominal voltage range	VAC	200 .. 240	200 .. 240
Frequency	Hz	50/60	50/60
Method of obtaining data		ml	ml
Speed (rpm)	min ⁻¹	1450	950
Power consumption	W	160	-
Current draw	A	1.3	
Max. back pressure	Pa	110	
Max. back pressure	inH ₂ O	0.44	
Min. ambient temperature	°C	-40	-40
Max. ambient temperature	°C	40	40

ml = Max. load · me = Max. efficiency · fa = Free air · cs = Customer specification · ce = Customer equipment
Subject to change

Data according to ErP Directive

		Actual	Req. 2015			
01 Overall efficiency η_{es}	%	42.1	28.5	09 Power consumption P_{ed}	kW	0.15
02 Measurement category		A		09 Air flow q_v	m ³ /h	2255
03 Efficiency category		Static		09 Pressure increase p_{fs}	Pa	90
04 Efficiency grade N		53.6	40	10 Speed (rpm) n	min ⁻¹	1460
05 Variable speed drive		Yes		11 Specific ratio*		1.00

Data obtained at optimum efficiency level.

The ErP data is determined using a motor-impeller combination in a standardized measurement setup.

* Specific ratio = $1 + p_s / 100\,000\text{ Pa}$

LU-152027



Technical description

Weight	2 kg
Fan size	350 mm
Electronics housing material	Die-cast aluminum
Blade material	PP plastic
Number of blades	5
Airflow direction	"V"
Direction of rotation	Counterclockwise, viewed toward rotor
Degree of protection	IP54
Insulation class	"B"
Moisture (F) / Environmental (H) protection class	F3-1
Max. permitted ambient temp. for motor (transport/storage)	+ 80 °C
Min. permitted ambient temp. for motor (transport/storage)	- 40 °C
Installation position	Shaft horizontal or rotor on bottom; rotor on top on request
Condensation drainage holes	None, open rotor
Cooling hole/opening	On rotor side
Mode	S1
Motor bearing	Ball bearing with low-temperature lubricant
Technical features	<ul style="list-style-type: none"> - Speed setting input (230 V) - Power limiter - Motor current limitation - Soft start - Thermal overload protection for motor
Speed levels	2
Touch current according to IEC 60990 (measuring circuit Fig. 4, TN system)	<= 3.5 mA
Electrical hookup	With plug
Motor protection	PTC thermistor
With cable	Variable
Protection class	I (with customer connection of protective earth)
Conformity with standards	EN 60335-1; CE
Approval	CCC

EC axial fan

sickle-shaped blades (S series)

Product drawing

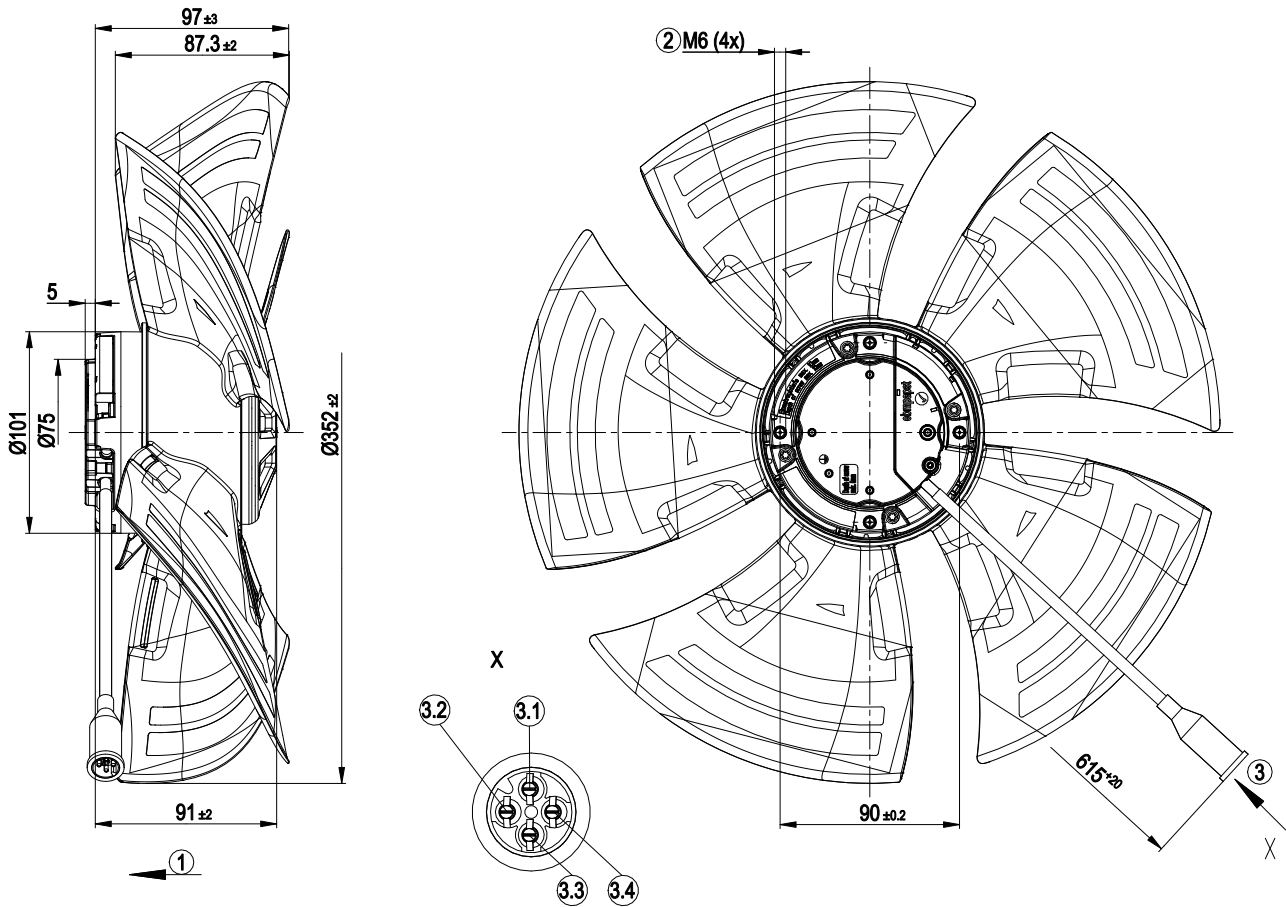

1	Direction of air flow "V"
2	Max. clearance for screw 10 mm
3	Cable PVC 4G 0.5 mm ² , 4-pole connector housing tyco 925075-7 with insulating sleeve, 4x plug pin tyco 163555-8
3.1	black
3.2	brown
3.3	green/yellow
3.4	blue



EC axial fan

sickle-shaped blades (S series)

Connection diagram

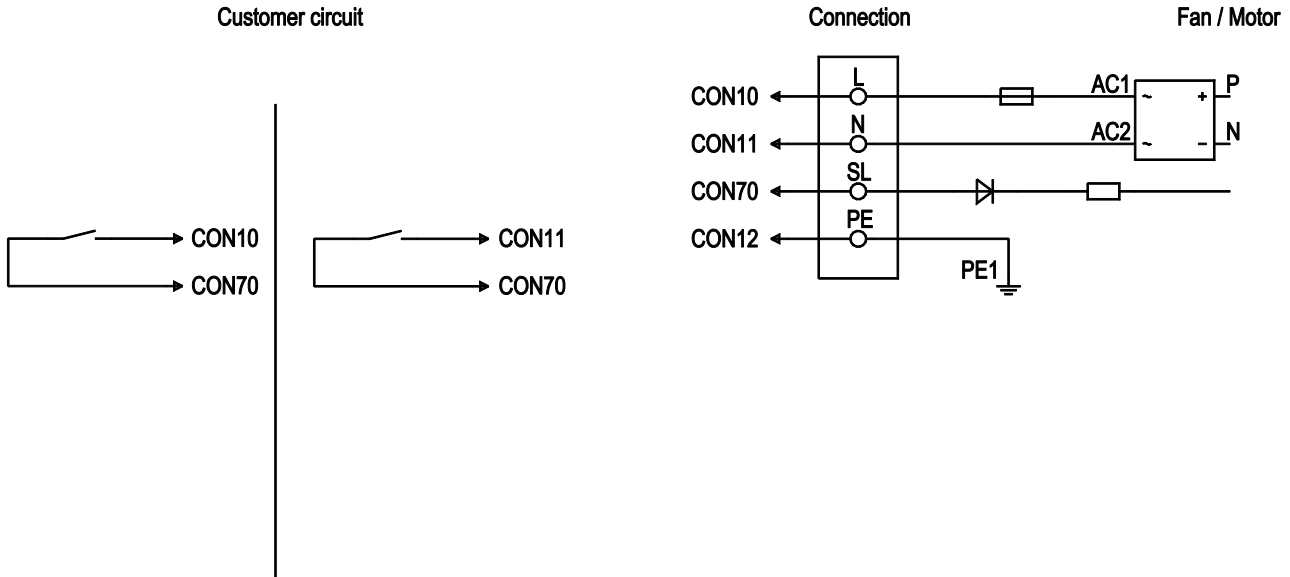

No.	Conn.	Designation	Color	Function/assignment
	CON 10	L	black	Power supply 230 VAC, 50-60 Hz, see nameplate for voltage range
	CON 11	N	blue	Neutral conductor
	CON 12	PE	green/yellow	Protective earth
	CON 70	SL	brown	Speed selection: switch open speed 1; switch closed speed 2



Curves: Air performance 50 Hz

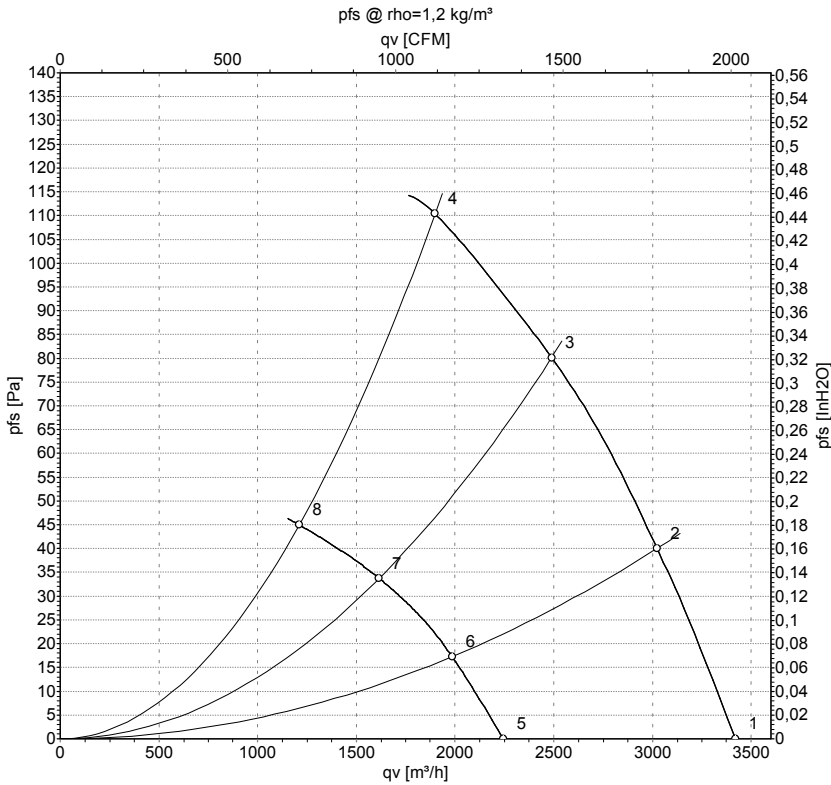

Measurement: LU-152027-1
Measurement: LU-151493-1

Air performance measured according to ISO 5801 installation category A. For detailed information on the measurement setup, contact ebm-papst. Intake sound level: Sound power level according to ISO 13347 / sound pressure level measured at 1 m distance from fan axis. The values given are valid under the specified measuring conditions and may vary due to conditions of installation. For deviations from the standard configuration, the parameters have to be checked on the installed unit.

Measured values

	U	f	n	P _{ed}	I	q _v	p _{fs}	q _v	p _{fs}
	V	Hz	min ⁻¹	W	A	m ³ /h	Pa	cfm	inH2O
1	230	50	1460	110	0.94	3420	0	2015	0.00
2	230	50	1455	129	1.09	3025	40	1780	0.16
3	230	50	1455	148	1.24	2490	80	1465	0.32
4	230	50	1450	160	1.30	1900	110	1115	0.44
5	230	50	950	33	0.31	2245	0	1320	0.00
6	230	50	950	37	0.35	1985	19	1170	0.08
7	230	50	950	42	0.38	1615	34	950	0.14
8	230	50	950	45	0.40	1210	45	715	0.18

U = Power supply · f = Frequency · n = Speed (rpm) · P_{ed} = Power consumption · I = Current draw · q_v = Air flow · p_{fs} = Pressure increase

