

A3G350-AG03-04 ebmpapst Datasheet

sales@fansco.com

www.fansco.com

Limited partnership · Headquarters Muldingen

Amtsgericht (court of registration) Stuttgart · HRA 590344

General partner Elektrobau Muldingen GmbH · Headquarters Muldingen

Amtsgericht (court of registration) Stuttgart · HRB 590142

Nominal data

Type	A3G350-AG03-04	
Motor	M3G055-DF	
Phase		1~
Nominal voltage	VAC	230
Nominal voltage range	VAC	200 .. 240
Frequency	Hz	50/60
Method of obtaining data		ml
Speed (rpm)	min ⁻¹	1040
Power consumption	W	73
Current draw	A	0.65
Max. back pressure	Pa	55
Max. back pressure	inH ₂ O	0.22
Min. ambient temperature	°C	-25
Max. ambient temperature	°C	60

ml = Max. load · me = Max. efficiency · fa = Free air · cs = Customer specification · ce = Customer equipment
Subject to change



Technical description

Weight	1.7 kg
Fan size	350 mm
Rotor surface	Thick-film passivated
Electronics housing material	Die-cast aluminum
Blade material	Press-fitted sheet steel blank, sprayed with PP plastic
Number of blades	5
Airflow direction	"A"
Direction of rotation	Clockwise, viewed toward rotor
Degree of protection	IP54
Insulation class	"B"
Max. permitted ambient temp. for motor (transport/storage)	+ 80 °C
Min. permitted ambient temp. for motor (transport/storage)	- 40 °C
Installation position	Any
Condensation drainage holes	None, open rotor
Mode	S1
Motor bearing	Ball bearing
Technical features	<ul style="list-style-type: none"> - Output 10 VDC, max. 1.1 mA - Tach output - Power limiter - Motor current limitation - Soft start - Control input 0-10 VDC / PWM - Control interface with SELV potential safely disconnected from the mains - Overvoltage detection - Thermal overload protection for electronics/motor - Line undervoltage detection
Touch current according to IEC 60990 (measuring circuit Fig. 4, TN system)	<= 3.5 mA
Motor protection	Locked-rotor protection
With cable	Variable
Protection class	I (with customer connection of protective earth)
Conformity with standards	EN 60335-1; CE

EC axial fan

sickle-shaped blades (S series)

Product drawing

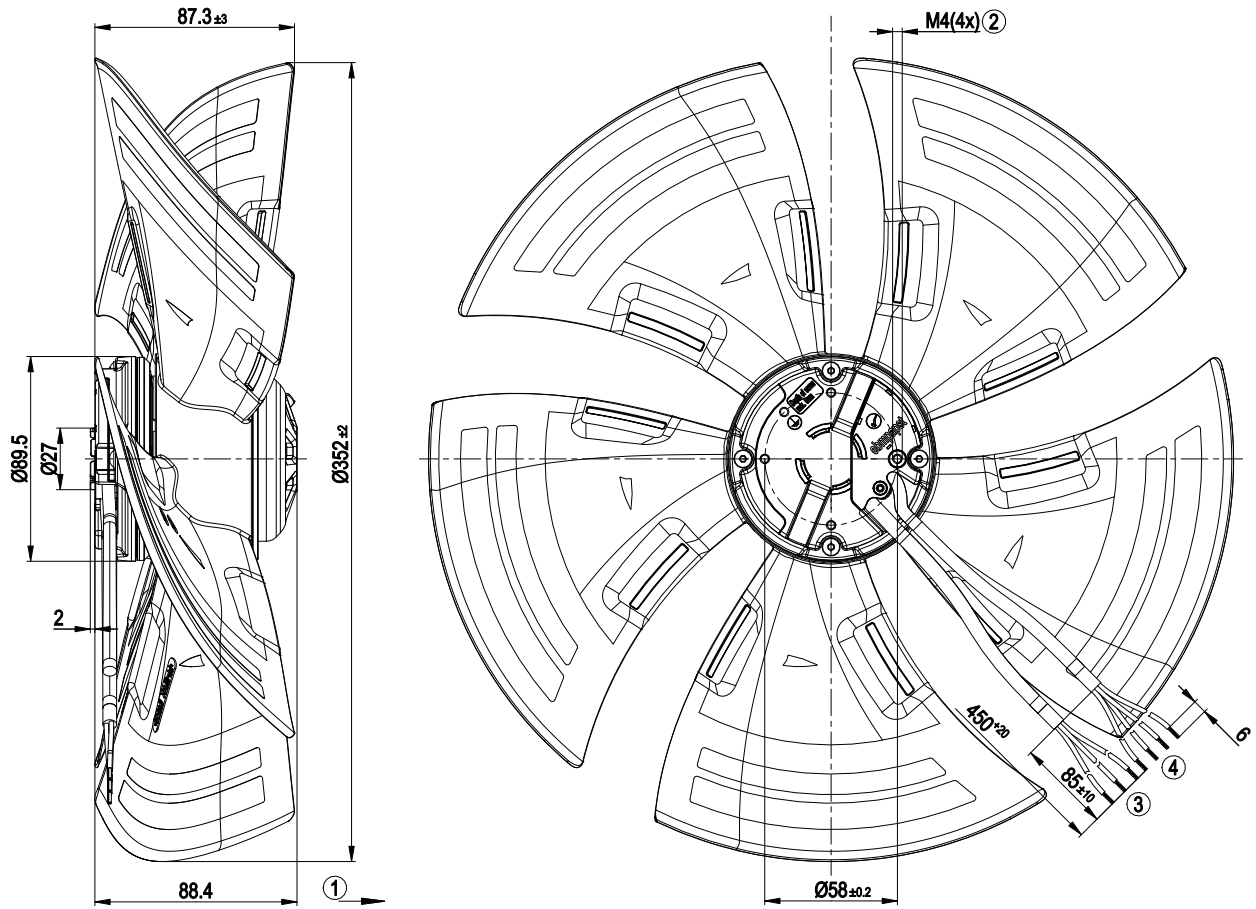

1	Direction of air flow "A"
2	Max. clearance for screw 5 mm
3	Cable PVC 3X AWG20, 3x crimped splices
4	Cable PVC 4X AWG22, 4x crimped splices



Connection diagram

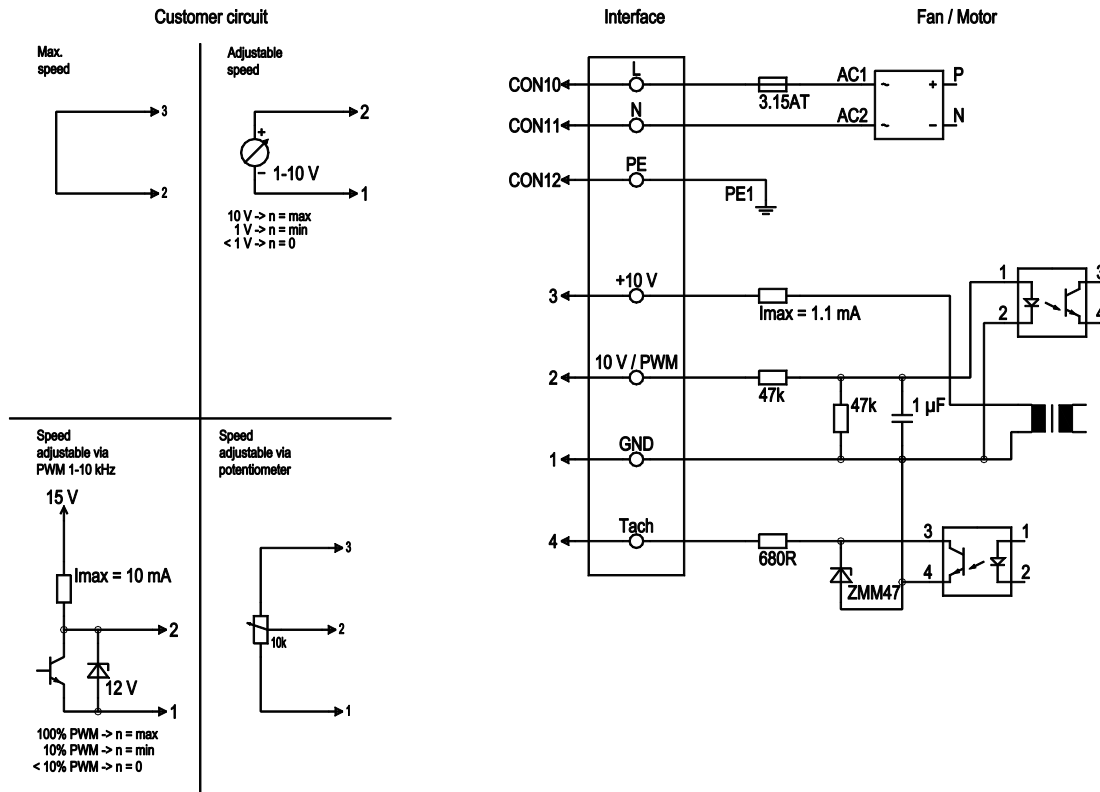

No.	Conn.	Designation	Color	Function/assignment
	CON10	L	black	Power supply 230 VAC, 50-60 Hz, see nameplate for voltage range
	CON11	N	blue	Neutral conductor
	CON12	PE	green/yellow	Protective earth
	1	GND	blue	GND connection for control interface
	2	0-10V PWM	yellow	Control input 0-10 V or PWM, electrically isolated
	3	10 V / max. 1,1 mA	red	Voltage output 10 VDC 1.1 mA, electrically isolated, short-circuit-proof
	4	Tacho	white	Tach output: open collector, 1 pulse per revolution, electrically isolated

Curves: Air performance 50 Hz

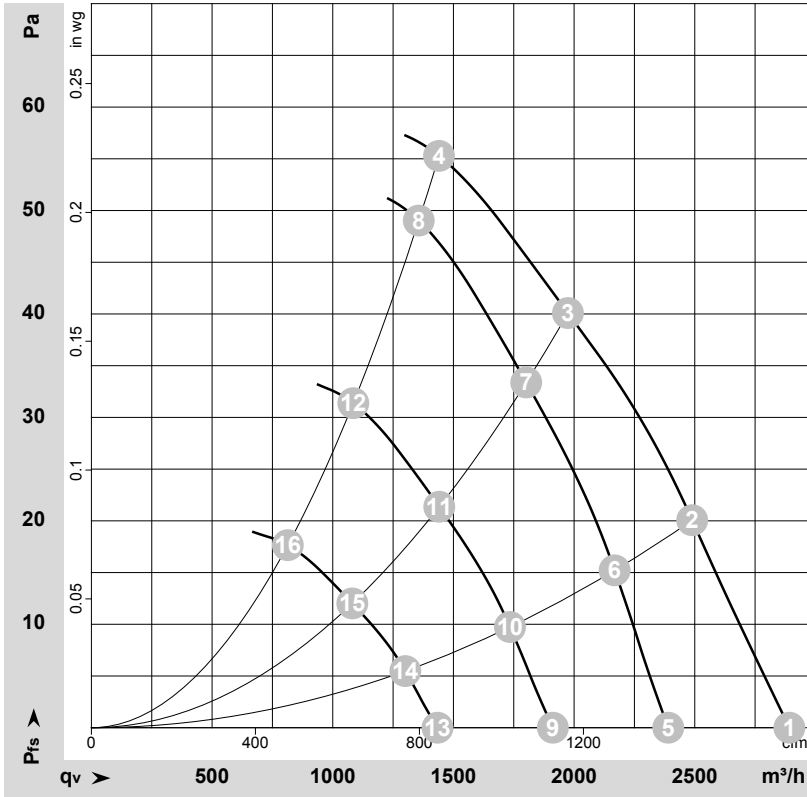

$\rho = 1.15 \text{ kg/m}^3 \pm 2 \%$

Measurement: LU-165180-1

Air performance measured according to ISO 5801 installation category A. For detailed information on the measurement setup, contact ebmpapst. Intake sound level: Sound power level according to ISO 13347 / sound pressure level measured at 1 m distance from fan axis. The values given are valid under the specified measuring conditions and may vary due to conditions of installation. For deviations from the standard configuration, the parameters have to be checked on the installed unit.

Measured values

	U	f	n	P _{ed}	I	LpA _{in}	LwA _{in}	qv	p _{fs}	qv	p _{fs}
	V	Hz	min ⁻¹	W	A	dB(A)	dB(A)	m ³ /h	Pa	CFM	inH ₂ O
1	230	50	1210	73	0.65	59	65	2890	0	1700	0.00
2	230	50	1150	73	0.65	55	62	2490	20	1465	0.08
3	230	50	1095	73	0.65	52	59	1975	40	1160	0.16
4	230	50	1040	73	0.65	49	56	1440	55	850	0.22
5	230	50	1000	41	0.37			2390	0	1405	0.00
6	230	50	1000	49	0.43			2170	15	1275	0.06
7	230	50	1000	56	0.50			1800	33	1060	0.13
8	230	50	1000	61	0.55			1355	49	800	0.20
9	230	50	800	21	0.19			1910	0	1125	0.00
10	230	50	800	25	0.22			1735	10	1020	0.04
11	230	50	800	28	0.25			1440	21	850	0.08
12	230	50	800	31	0.28			1085	31	640	0.12
13	230	50	600	9.0	0.08			1435	0	845	0.00
14	230	50	600	10.0	0.09			1300	5	765	0.02
15	230	50	600	12	0.11			1080	12	635	0.05
16	230	50	600	13	0.12			815	18	480	0.07

U = Power supply · f = Frequency · n = Speed (rpm) · P_{ed} = Power consumption · I = Current draw · LpA_{in} = Sound pressure level intake side · LwA_{in} = Sound power level intake side
 qv = Air flow · p_{fs} = Pressure increase

