

A3G300-AL11-09 ebmpapst Datasheet

sales@fansco.com

www.fansco.com

Limited partnership · Headquarters Mulfingen

Amtsgericht (court of registration) Stuttgart · HRA 590344

General partner Elektrobau Mulfingen GmbH · Headquarters Mulfingen

Amtsgericht (court of registration) Stuttgart · HRB 590142

Nominal data

Type	A3G300-AL11-09	
Motor	M3G055-DF	
Phase		1~
Nominal voltage	VAC	230
Nominal voltage range	VAC	200 .. 240
Frequency	Hz	50/60
Method of obtaining data		ml
Speed (rpm)	min ⁻¹	1560
Power consumption	W	97
Current draw	A	0.8
Max. back pressure	Pa	98
Max. back pressure	inH ₂ O	0.39
Min. ambient temperature	°C	-25
Max. ambient temperature	°C	60

ml = Max. load · me = Max. efficiency · fa = Free air · cs = Customer specification · ce = Customer equipment
Subject to change



Technical description

Weight	1.8 kg
Fan size	300 mm
Rotor surface	Passivated
Impeller material	PP plastic
Airflow direction	"A"
Direction of rotation	Clockwise, viewed toward rotor
Degree of protection	IP54
Insulation class	"B"
Max. permitted ambient temp. for motor (transport/storage)	+ 80 °C
Min. permitted ambient temp. for motor (transport/storage)	- 40 °C
Installation position	Any
Condensation drainage holes	None, open rotor
Mode	S1
Motor bearing	Ball bearing
Technical features	<ul style="list-style-type: none"> - Output 10 VDC, max. 1.1 mA - Tach output - Motor current limitation - Soft start - Control input 0-10 VDC / PWM - Thermal overload protection for electronics/motor - Line undervoltage detection
EMC immunity to interference	According to EN 61000-6-2 (industrial environment)
EMC circuit feedback	According to EN 61000-3-2/3
EMC interference emission	According to EN 61000-6-3 (household environment)
Touch current according to IEC 60990 (measuring circuit Fig. 4, TN system)	<= 3.5 mA
Motor protection	Locked-rotor protection
With cable	Variable
Protection class	I (with customer connection of protective earth)
Conformity with standards	EN 60335-1; CE

EC axial fan

sickle-shaped blades (S series)

Product drawing

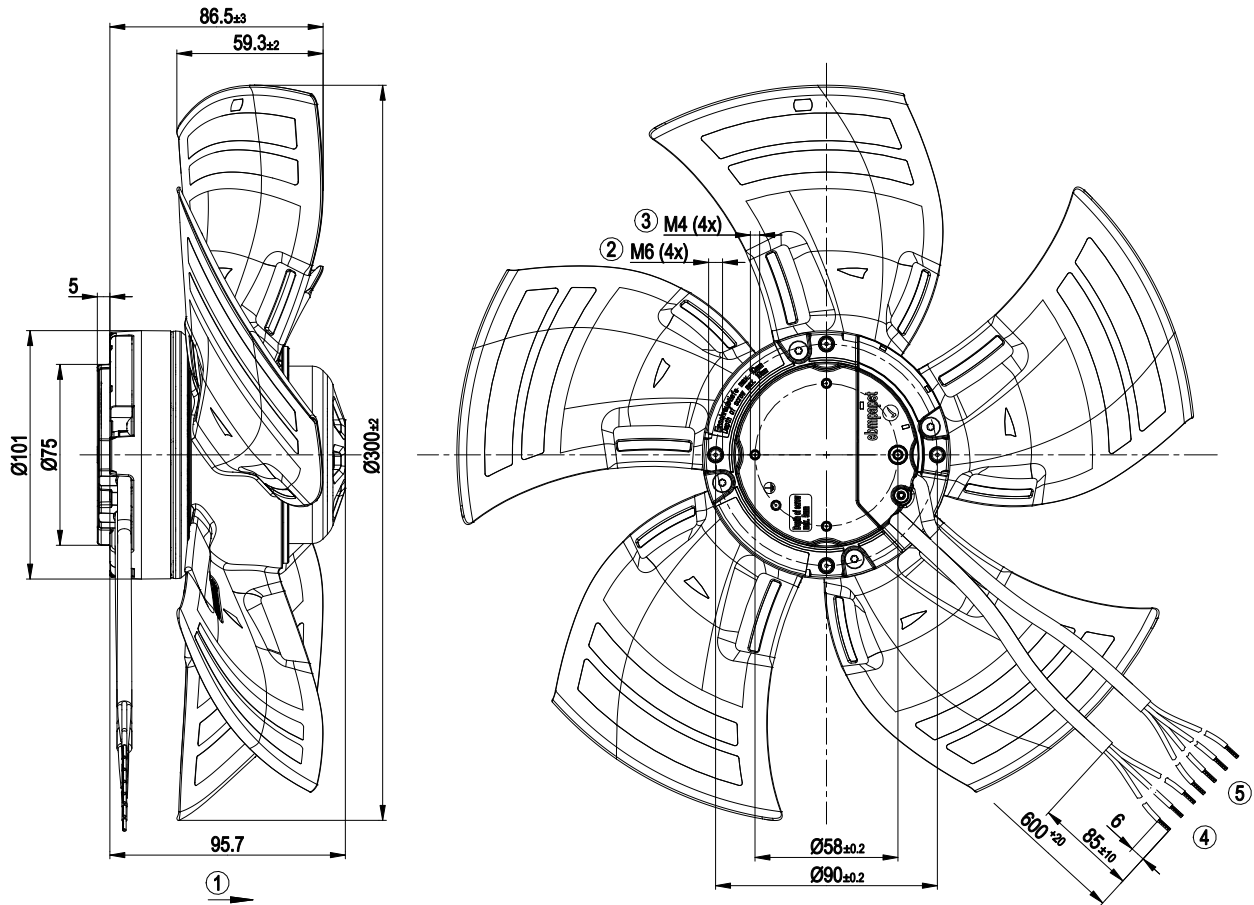

1	Direction of air flow "A"
2	Max. clearance for screw 10 mm
3	Max. clearance for screw 5 mm
4	Cable PVC 3x AWG20, 3x crimped splices
5	Cable PVC 4x AWG22, 4 x crimped splices



Connection diagram

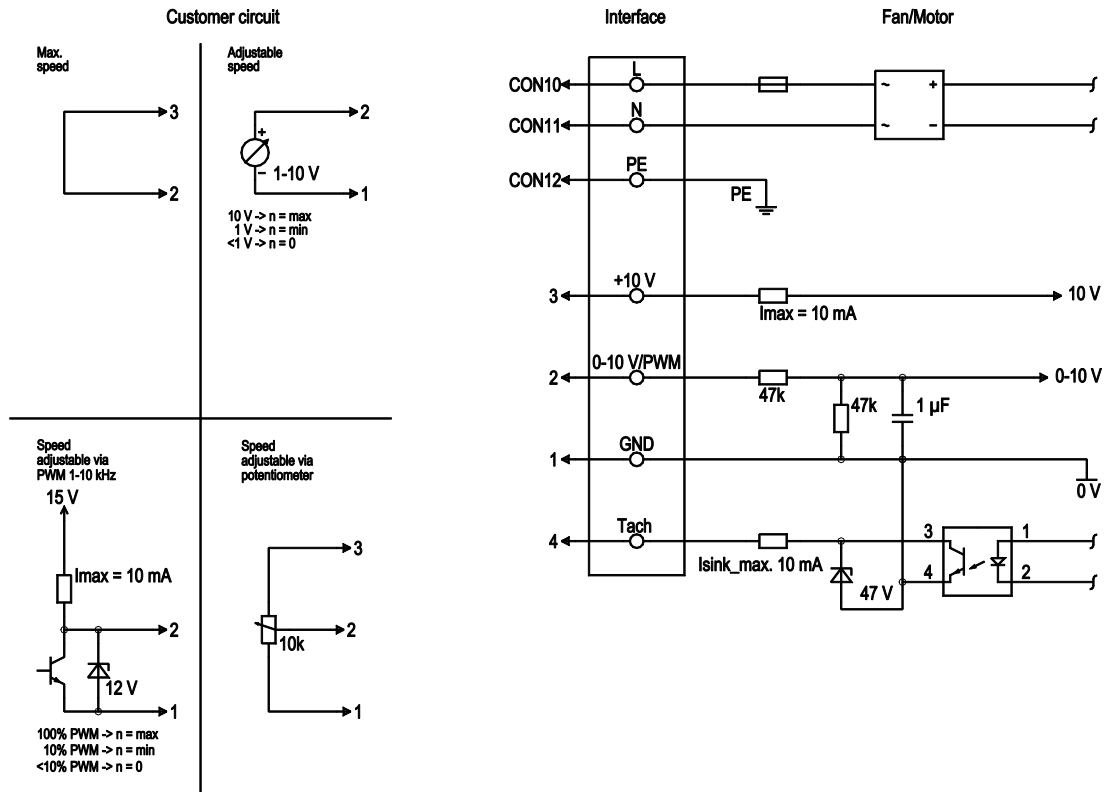

No.	Conn.	Designation	Color	Function/assignment
	CON10	L	black	Supply connection, power supply, phase, see nameplate for voltage range
	CON11	N	blue	Supply connection, power supply, neutral conductor, see nameplate for voltage range
	CON12	PE	green/yellow	Ground connection
	2	0- 10V PWM	yellow	0-10 V / PWM control input, R _i =100 kΩ, SELV
	4	Tach	white	Tach output, open collector, 1 pulse per revolution, I _{sink max} = 10 mA, SELV
	3	+10 V	red	Fixed voltage output 10 VDC +/-3 %, I _{max} . 10 mA, short-circuit-proof, power supply for ext. devices (e.g. pot), SELV
	1	GND	blue	Reference ground for control interface, SELV

Curves: Air performance 50 Hz

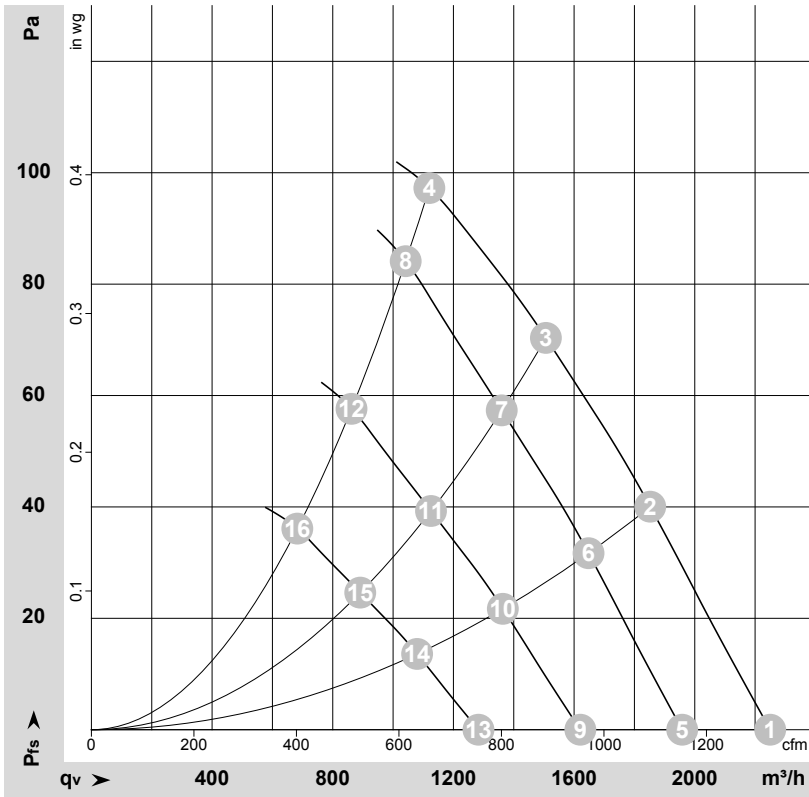

$\rho = 1.15 \text{ kg/m}^3 \pm 2 \%$

Measurement: LU-166935-1

Air performance measured according to ISO 5801 installation category A. For detailed information on the measurement setup, contact ebmpapst. Intake sound level: Sound power level according to ISO 13347 / sound pressure level measured at 1 m distance from fan axis. The values given are valid under the specified measuring conditions and may vary due to conditions of installation. For deviations from the standard configuration, the parameters have to be checked on the installed unit.

Measured values

	U	f	n	P _{ed}	I	LpA _{in}	LwA _{in}	qv	p _{fs}	qv	p _{fs}
	V	Hz	min ⁻¹	W	A	dB(A)	dB(A)	m ³ /h	Pa	CFM	inH ₂ O
1	230	50	1665	73	0.64	58	65	2250	0	1325	0.00
2	230	50	1630	82	0.71	58	65	1850	40	1090	0.16
3	230	50	1605	87	0.75	58	65	1505	70	885	0.28
4	230	50	1560	97	0.80	60	68	1120	98	660	0.39
5	230	50	1450	48	0.42	55	61	1960	0	1150	0.00
6	230	50	1450	58	0.50	55	62	1650	32	970	0.13
7	230	50	1450	64	0.55	56	63	1360	57	800	0.23
8	230	50	1450	78	0.66	59	66	1040	85	615	0.34
9	230	50	1200	27	0.24	50	57	1620	0	955	0.00
10	230	50	1200	33	0.28	50	57	1365	22	805	0.09
11	230	50	1200	36	0.31	51	58	1125	39	665	0.16
12	230	50	1200	44	0.38	54	61	860	58	505	0.23
13	230	50	950	14	0.12	44	51	1285	0	755	0.00
14	230	50	950	16	0.14	44	51	1080	14	635	0.06
15	230	50	950	18	0.15	45	52	890	25	525	0.10
16	230	50	950	22	0.19	48	55	685	36	400	0.14

U = Power supply · f = Frequency · n = Speed (rpm) · P_{ed} = Power consumption · I = Current draw · LpA_{in} = Sound pressure level intake side · LwA_{in} = Sound power level intake side
 qv = Air flow · p_{fs} = Pressure increase

