

A3G300-AK13-08 ebmpapst Datasheet

sales@fansco.com

www.fansco.com

Limited partnership · Headquarters Muldingen

Amtsgericht (court of registration) Stuttgart · HRA 590344

General partner Elektrobau Muldingen GmbH · Headquarters Muldingen

Amtsgericht (court of registration) Stuttgart · HRB 590142

Nominal data

Type	A3G300-AK13-08	
Motor	M3G055-CF	
Phase		1~
Nominal voltage	VAC	230
Nominal voltage range	VAC	200 .. 240
Frequency	Hz	50/60
Method of obtaining data		ml
Speed (rpm)	min ⁻¹	1500
Power consumption	W	85
Current draw	A	0.8
Max. back pressure	Pa	85
Max. back pressure	inH ₂ O	0.34
Min. ambient temperature	°C	-40
Max. ambient temperature	°C	40

ml = Max. load · me = Max. efficiency · fa = Free air · cs = Customer specification · ce = Customer equipment
Subject to change



Technical description

Weight	1.4 kg
Fan size	300 mm
Rotor surface	Passivated
Electronics housing material	Die-cast aluminum
Impeller material	PP plastic
Number of blades	5
Airflow direction	"V"
Direction of rotation	Counterclockwise, viewed toward rotor
Degree of protection	IP54
Insulation class	"B"
Max. permitted ambient temp. for motor (transport/storage)	+ 80 °C
Min. permitted ambient temp. for motor (transport/storage)	- 40 °C
Installation position	Any
Condensation drainage holes	None, open rotor
Mode	S1
Motor bearing	Ball bearing with low-temperature lubricant
Technical features	- Soft start - Thermal overload protection for electronics/motor
Speed levels	2
EMC immunity to interference	According to EN 61000-6-2 (industrial environment)
EMC circuit feedback	According to EN 61000-3-2/3
EMC interference emission	According to EN 61000-6-3 (household environment)
Touch current according to IEC 60990 (measuring circuit Fig. 4, TN system)	<= 3.5 mA
Motor protection	Locked-rotor protection
With cable	Variable
Protection class	I (with customer connection of protective earth)
Conformity with standards	EN 60335-1; CE
Approval	UL 1004-7 + 60730; C22.2 No.77 + CAN/CSA-E60730-1

Product drawing

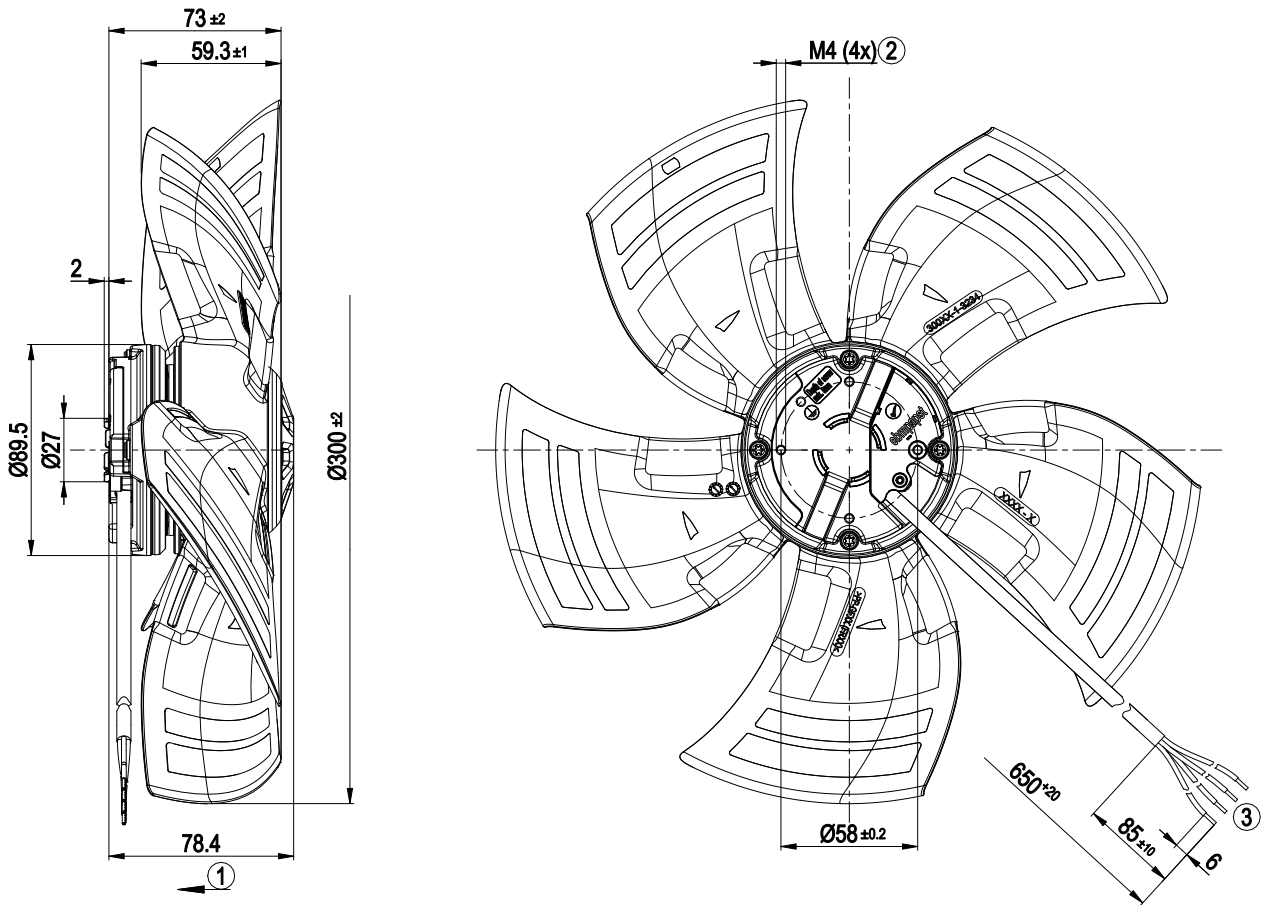

1	Direction of air flow "V"
2	Max. clearance for screw 5 mm
3	Cable PVC AWG20, 4x crimped splices

EC axial fan

sickle-shaped blades (S series)

Connection diagram

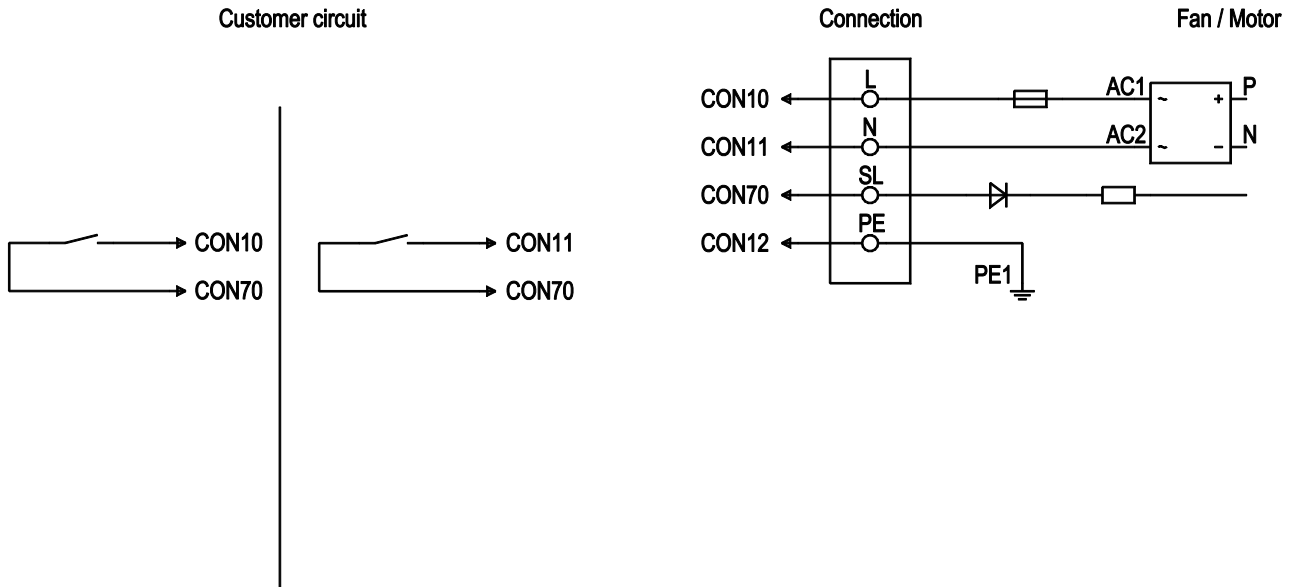

No.	Conn.	Designation	Color	Function/assignment
	CON 10	L	black	Power supply 230 VAC, 50-60 Hz, see nameplate for voltage range
	CON 11	N	blue	Neutral conductor
	CON 12	PE	green/yellow	Protective earth
	CON 70	SL	brown	Speed selection: switch open speed 1; switch closed speed 2



Curves: Air performance 50 Hz

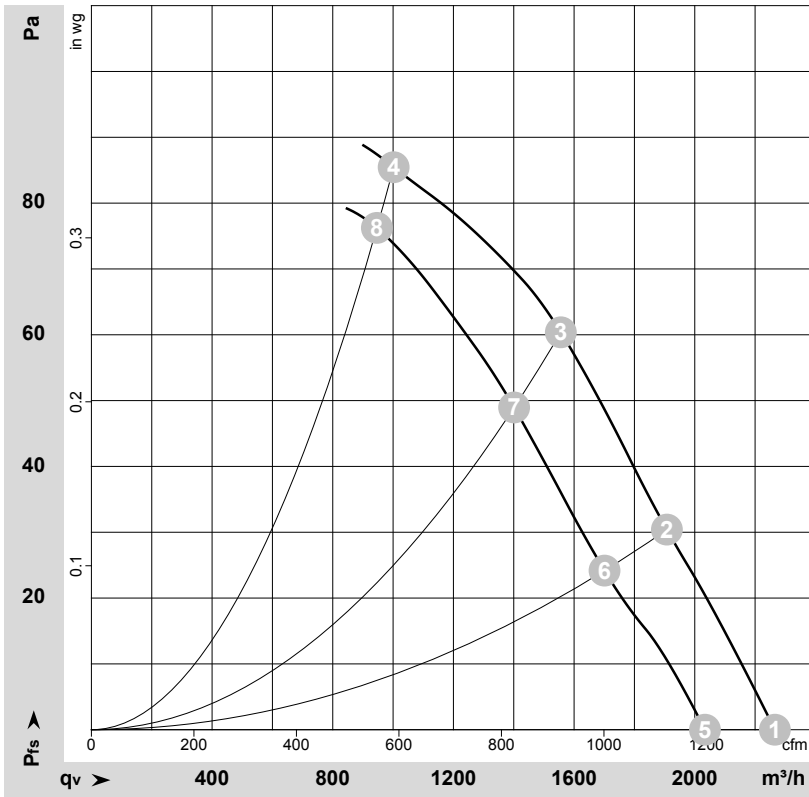

$\rho = 1.15 \text{ kg/m}^3 \pm 2 \%$

Measurement: LU-133717-1
Measurement: LU-133719-1

Air performance measured according to ISO 5801 installation category A. For detailed information on the measurement setup, contact ebm-papst. Intake sound level: Sound power level according to ISO 13347 / sound pressure level measured at 1 m distance from fan axis. The values given are valid under the specified measuring conditions and may vary due to conditions of installation. For deviations from the standard configuration, the parameters have to be checked on the installed unit.

Measured values

	U	f	n	P _{ed}	I	LpA _{in}	LwA _{in}	q _v	p _{fs}	q _v	p _{fs}
	V	Hz	min ⁻¹	W	A	dB(A)	dB(A)	m ³ /h	Pa	cfm	inH ₂ O
1	230	50	1650	72	0.63	55	63	2265	0	1335	0.00
2	230	50	1595	79	0.67	56	63	1910	30	1125	0.12
3	230	50	1560	85	0.80	54	62	1555	60	915	0.24
4	230	50	1500	85	0.80	58	67	1000	85	590	0.34
5	230	50	1485	52	0.48	53	60	2035	0	1195	0.00
6	230	50	1435	57	0.52	53	60	1700	24	1000	0.10
7	230	50	1405	60	0.54	52	60	1400	49	825	0.20
8	230	50	1350	66	0.60	57	65	945	76	555	0.31

U = Power supply · f = Frequency · n = Speed (rpm) · P_{ed} = Power consumption · I = Current draw · LpA_{in} = Sound pressure level intake side · LwA_{in} = Sound power level intake side
q_v = Air flow · p_{fs} = Pressure increase

