

A2S155-AA21-15 ebmpapst Datasheet

sales@fansco.com

www.fansco.com

Limited partnership · Headquarters Muldingen

Amtsgericht (court of registration) Stuttgart · HRA 590344

General partner Elektrobau Muldingen GmbH · Headquarters Muldingen

Amtsgericht (court of registration) Stuttgart · HRB 590142

## Nominal data

Type	A2S155-AA21-15	
Motor	M2S052-CA	
Phase		1~
Nominal voltage	VAC	230
Frequency	Hz	50
Method of obtaining data		fa
Valid for approval/standard		CE
Speed (rpm)	min <sup>-1</sup>	2700
Power consumption	W	42
Current draw	A	0.25
Min. ambient temperature	°C	-25
Max. ambient temperature	°C	35

ml = Max. load · me = Max. efficiency · fa = Free air · cs = Customer specification · ce = Customer equipment  
Subject to change



### Technical description

Weight	0.9 kg
Fan size	155 mm
Rotor surface	Unpainted
Impeller material	Sheet steel, galvanized
Number of blades	18
Airflow direction	"V"
Direction of rotation	Clockwise, viewed toward rotor
Degree of protection	IP44
Insulation class	"B"
Max. permitted ambient temp. for motor (transport/storage)	+ 80 °C
Min. permitted ambient temp. for motor (transport/storage)	- 40 °C
Installation position	Any
Condensation drainage holes	None
Mode	S1
Motor bearing	Ball bearing
Touch current according to IEC 60990 (measuring circuit Fig. 4, TN system)	< 0.75 mA
Motor protection	Thermal overload protector (TOP) internally connected
Protection class	I (with customer connection of protective earth)
Conformity with standards	CE

Product drawing

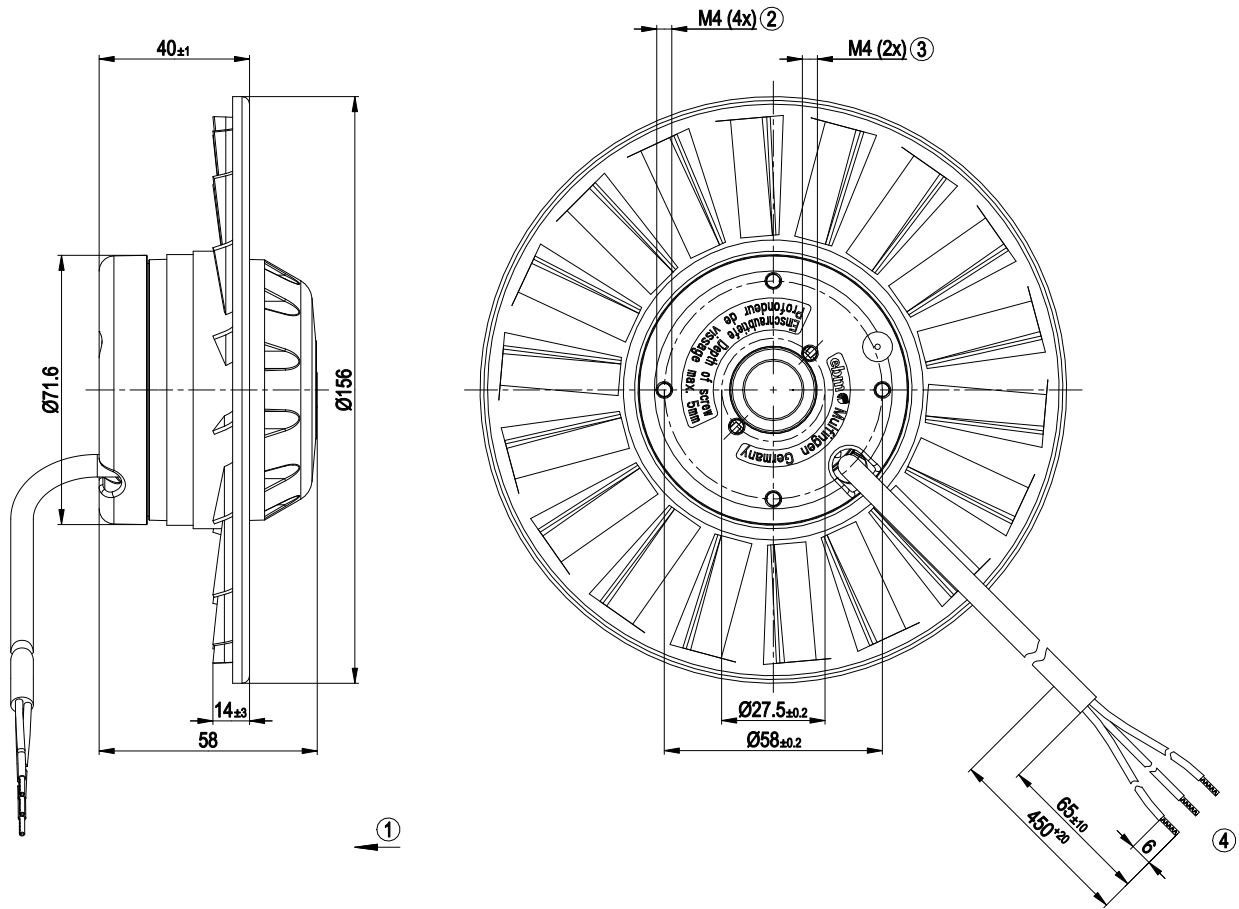

1	Airflow direction "V"
2	Max. clearance for screw 5 mm
3	Max. clearance for screw 5 mm
4	Cable PVC 3G 0.5 mm <sup>2</sup> , 3x crimped splices

## Connection diagram

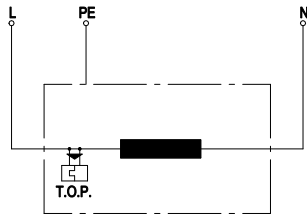

L	= blue
PE	= green/yellow
N	= brown
TOP	= thermal overload protector

## Curves: Air performance 50 Hz

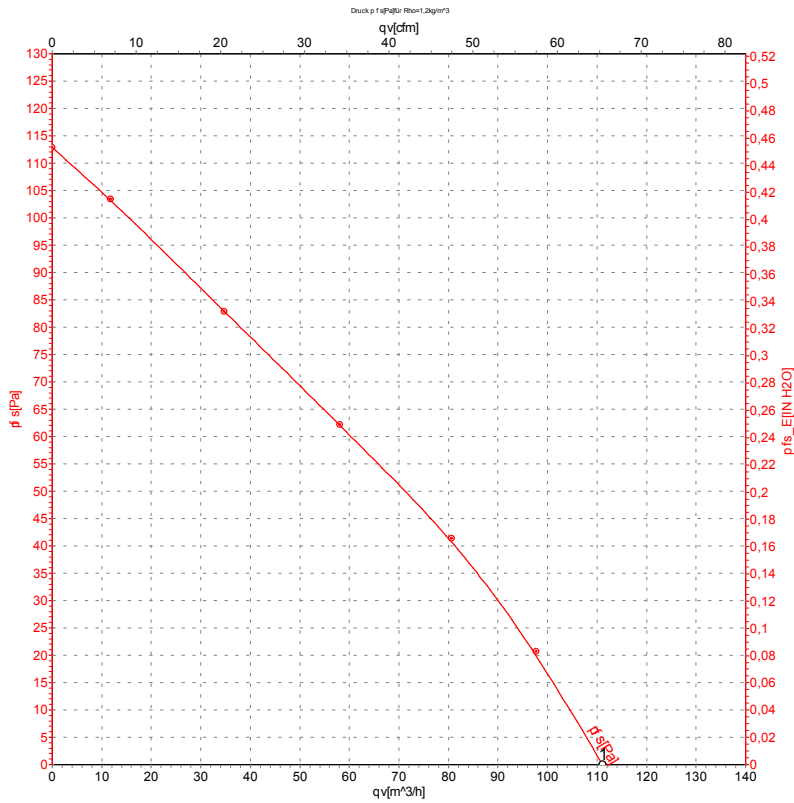

Measurement: LU-32682-1

Air performance measured according to ISO 5801 installation category A. For detailed information on the measurement setup, contact ebm-papst. Intake sound level: Sound power level according to ISO 13347 / sound pressure level measured at 1 m distance from fan axis. The values given are valid under the specified measuring conditions and may vary due to conditions of installation. For deviations from the standard configuration, the parameters have to be checked on the installed unit.

## Measured values

	U	f	n	P <sub>e</sub>	I	q <sub>v</sub>	q <sub>v</sub>	P <sub>fs</sub>
	V	Hz	min <sup>-1</sup>	W	A	m <sup>3</sup> /h	cfm	inH <sub>2</sub> O
1	230	50	2700	42	0.25	110	65	0.00

U = Power supply · f = Frequency · n = Speed (rpm) · P<sub>e</sub> = Power consumption · I = Current draw · q<sub>v</sub> = Air flow

