

AC axial fan

straight blades (A series)

A2S130-AB03-09 ebmpapst Datasheet FansCo

sales@fansco.com

www.fansco.com

Nominal data

Type	A2S130-AB03-09		
Motor	M2S052-CA		
Phase		1~	1~
Nominal voltage	VAC	220	240
Frequency	Hz	50	60
Method of obtaining data		fa	fa
Valid for approval/standard		CE	CE
Speed (rpm)	min ⁻¹	2760	2800
Power consumption	W	40	50
Current draw	A	0.25	0.3
Max. ambient temperature	°C	40	40

ml = Max. load · me = Max. efficiency · fa = Free air · cs = Customer specification · ce = Customer equipment
Subject to change



Technical description

Weight	0.866 kg
Size	130 mm
Motor size	52
Rotor surface	Painted black
Blade material	Sheet steel, painted black
Number of blades	7
Airflow direction	V
Direction of rotation	Counterclockwise, viewed toward rotor
Degree of protection	IP44; installation- and position-dependent
Insulation class	"B"
Moisture (F) / Environmental (H) protection class	H0+
Max. permitted ambient temp. for motor (transport/storage)	+ 80 °C
Min. permitted ambient temp. for motor (transport/storage)	- 40 °C
Installation position	Any
Condensation drainage holes	None
Mode	S1
Motor bearing	Ball bearing
Touch current according to IEC 60990 (measuring circuit Fig. 4, TN system)	< 0.75 mA
Motor protection	Thermal overload protector (TOP) internally connected
With cable	Variable
Protection class	Built-in component with basic insulation, protection class results from installation according to intended use
Conformity with standards	EN 60335-1; CE

Product drawing

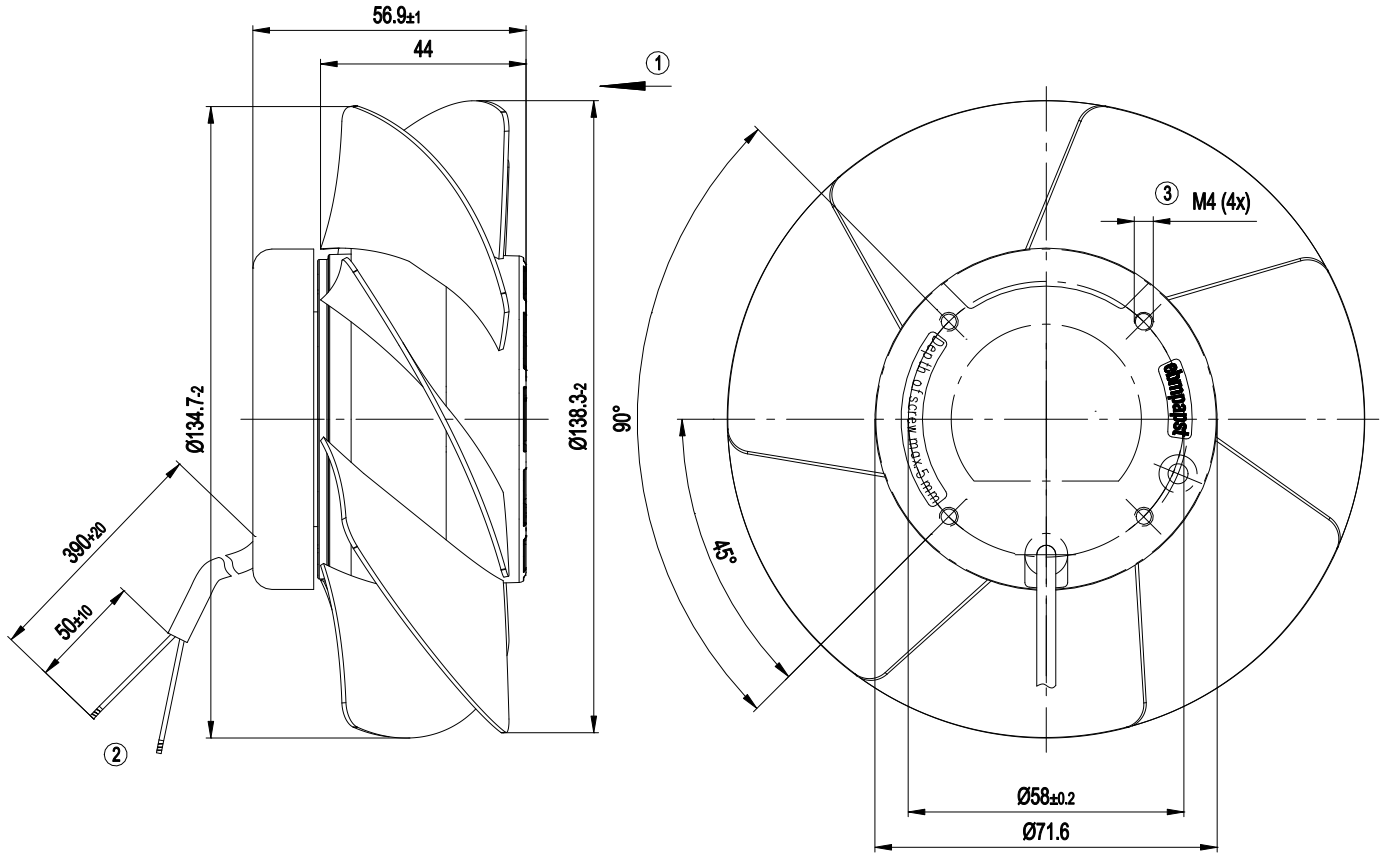

1	Direction of air flow "V"
2	Cable PVC 2 X 0.5 mm ² , 2x crimped splice
3	Max. clearance for screw 5 mm

Connection diagram

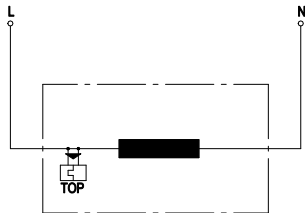

L	= blue
N	= brown
TOP	Thermal overload protector

Curves: Air performance 50 Hz

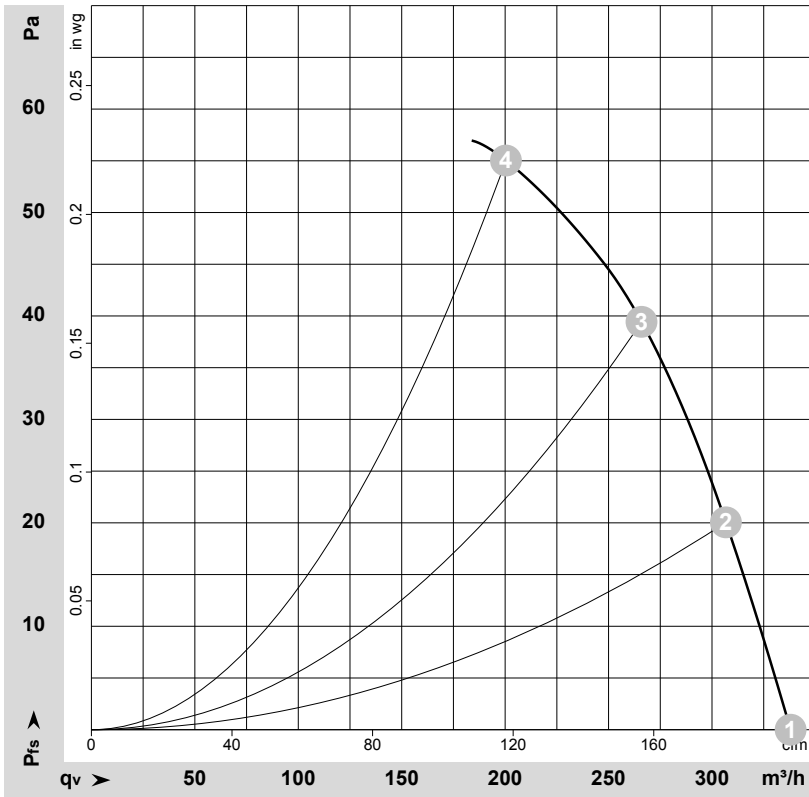

$\rho = 1.15 \text{ kg/m}^3 \pm 2 \%$

Measurement: LU-58475-1

Air performance measured according to ISO 5801 installation category A. For detailed information on the measurement setup, contact ebmpapst. Intake sound level: Sound power level according to ISO 13347 / sound pressure level measured at 1 m distance from fan axis. The values given are valid under the specified measuring conditions and may vary due to conditions of installation. For deviations from the standard configuration, the parameters have to be checked on the installed unit.

Measured values

	U	f	n	P _e	I	q _v	p _{fs}	q _v	p _{fs}
	V	Hz	min ⁻¹	W	A	m ³ /h	Pa	cfm	in. wg
1	230	50	2800	45	0.31	340	0	200	0.00
2	230	50	2795	45	0.31	305	20	180	0.08
3	230	50	2780	46	0.31	265	40	155	0.16
4	230	50	2780	46	0.31	200	55	120	0.22

U = Voltage · f = Frequency · n = Speed (rpm) · P_e = Power consumption · I = Current draw · q_v = Air flow · p_{fs} = Pressure increase



Curves: Air performance 60 Hz

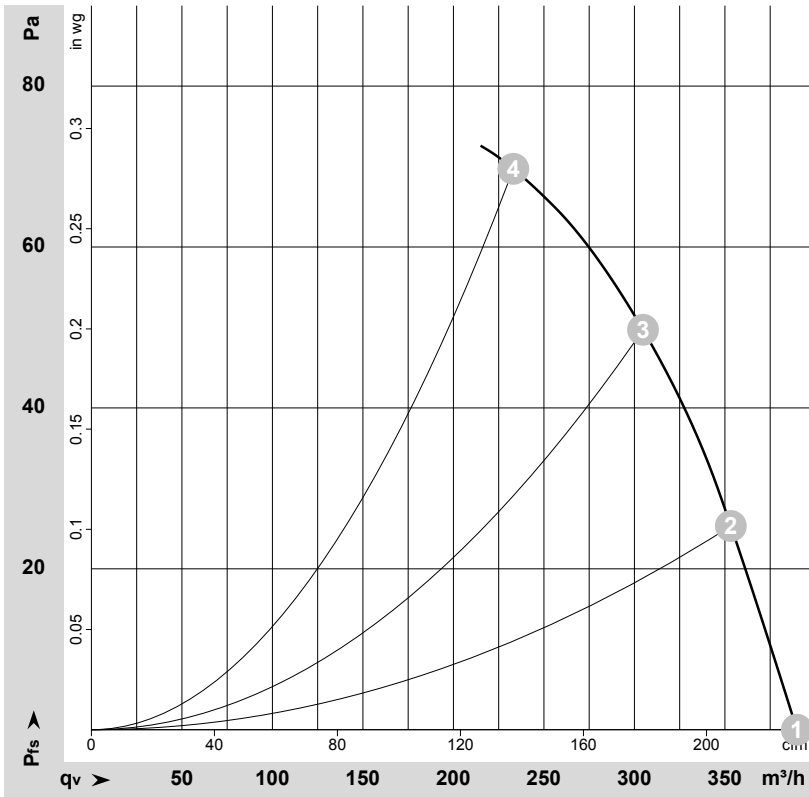

$\rho = 1.15 \text{ kg/m}^3 \pm 2 \%$

Measurement: LU-58476-1

Air performance measured according to ISO 5801 installation category A. For detailed information on the measurement setup, contact ebmpapst. Intake sound level: Sound power level according to ISO 13347 / sound pressure level measured at 1 m distance from fan axis. The values given are valid under the specified measuring conditions and may vary due to conditions of installation. For deviations from the standard configuration, the parameters have to be checked on the installed unit.

Measured values

	U	f	n	P _e	I	q _v	P _{fs}	q _v	P _{fs}
	V	Hz	min ⁻¹	W	A	m ³ /h	Pa	cfm	in. wg
1	230	60	3250	39	0.25	390	0	230	0.00
2	230	60	3200	42	0.25	355	25	210	0.10
3	230	60	3165	43	0.26	305	50	180	0.20
4	230	60	3145	44	0.26	235	70	135	0.28

U = Voltage · f = Frequency · n = Speed (rpm) · P_e = Power consumption · I = Current draw · q_v = Air flow · p_s = Pressure increase

