

A2E315-AP02-06 ebmpapst Datasheet

sales@fansco.com

www.fansco.com

Limited partnership · Headquarters Mulfingen

Amtsgericht (court of registration) Stuttgart · HRA 590344

General partner Elektrobau Mulfingen GmbH · Headquarters Mulfingen

Amtsgericht (court of registration) Stuttgart · HRB 590142



Nominal data

Type	A2E315-AP02-06		
Motor	M2E074-GA		
Phase		1~	1~
Nominal voltage	VAC	230	230
Frequency	Hz	50	60
Method of obtaining data		fa	fa
Valid for approval/standard		CE	CE
Speed (rpm)	min ⁻¹	2800	3200
Power consumption	W	280	435
Current draw	A	1.23	1.93
Capacitor	µF	10	10
Capacitor voltage	VDB	400	400
Max. back pressure	Pa	275	130
Max. back pressure	inH ₂ O	1.1	0.52
Min. ambient temperature	°C	-25	-25
Max. ambient temperature	°C	75	60
Starting current	A	3.7	3.3

ml = Max. load · me = Max. efficiency · fa = Free air · cs = Customer specification · ce = Customer equipment
Subject to change

Data according to ErP Directive

		Actual	Req. 2015			
01 Overall efficiency η_{es}	%	36.9	30.7	09 Power consumption P_e	kW	0.34
02 Measurement category		A		09 Air flow q_v	m ³ /h	2655
03 Efficiency category		Static		09 Pressure increase p_{fs}	Pa	175
04 Efficiency grade N		46.2	40	10 Speed (rpm) n	min ⁻¹	2710
05 Variable speed drive		No		11 Specific ratio*		1.00

Data obtained at optimum efficiency level.

The ErP data is determined using a motor-impeller combination in a standardized measurement setup.

* Specific ratio = $1 + p_{fs} / 100\,000\text{ Pa}$

LU-39002



Technical description

Weight	4.4 kg
Fan size	315 mm
Rotor surface	Painted black
Blade material	Sheet steel, painted black
Number of blades	5
Airflow direction	"V"
Direction of rotation	Counterclockwise, viewed toward rotor
Degree of protection	IP44; installation- and position-dependent as per EN 60034-5
Insulation class	"F"
Moisture (F) / Environmental (H) protection class	H0+
Max. permitted ambient temp. for motor (transport/storage)	+ 80 °C
Min. permitted ambient temp. for motor (transport/storage)	- 40 °C
Installation position	Shaft horizontal or rotor on bottom; rotor on top on request
Condensation drainage holes	On rotor side
Mode	S1
Motor bearing	Ball bearing
Touch current according to IEC 60990 (measuring circuit Fig. 4, TN system)	< 0.75 mA
Motor protection	Thermal overload protector (TOP) internally connected
With cable	Variable
Protection class	I (with customer connection of protective earth)
Conformity with standards	EN 60335-1; CE

Product drawing

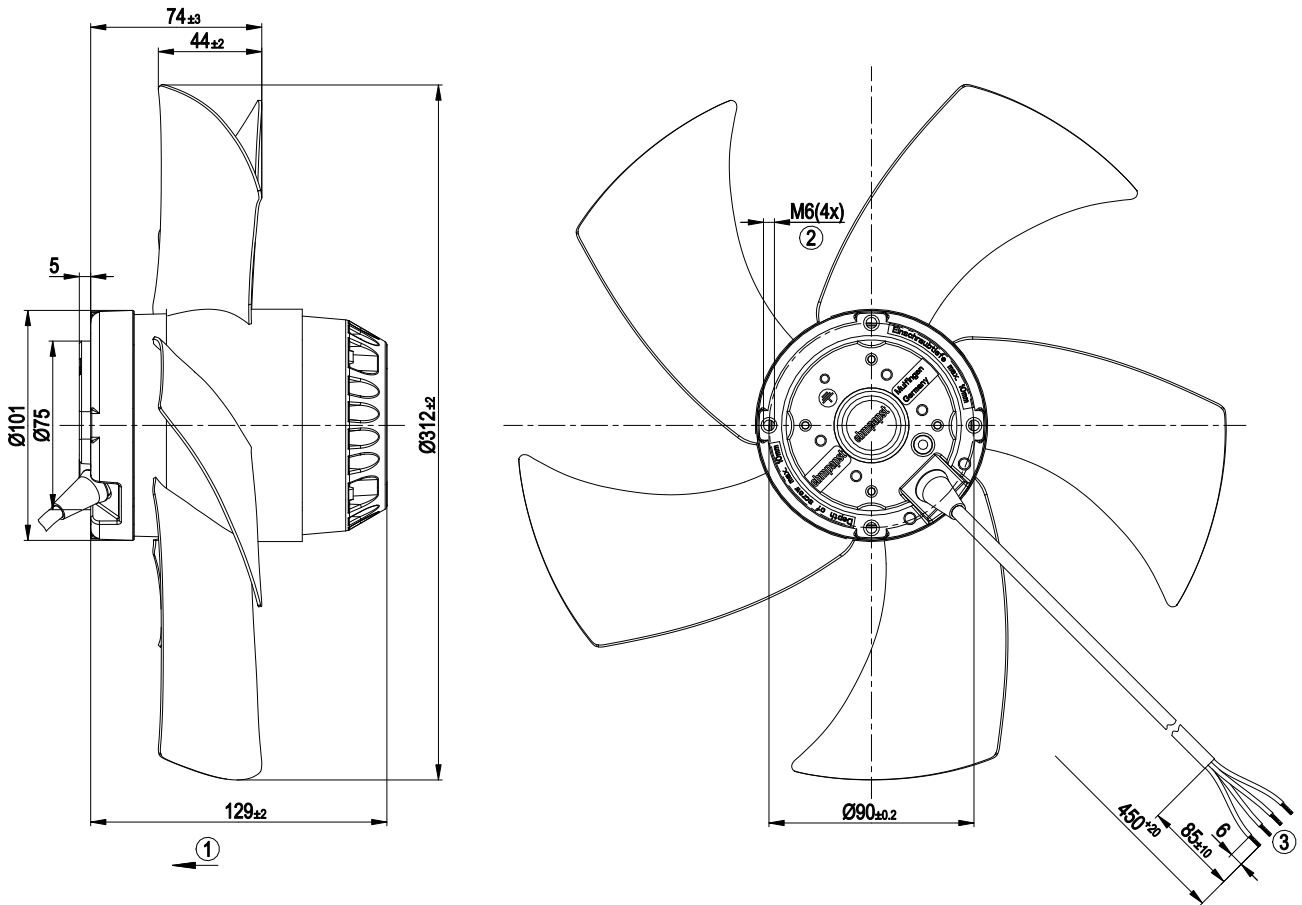

1	Direction of air flow "V"
2	Max. clearance for screw 10 mm
3	Cable silicone 4G 0.5 mm ² , 4x crimped splices

Connection diagram



U1	blue	Z	brown	U2	black
PE	green/yellow				

Curves: Air performance 50 Hz

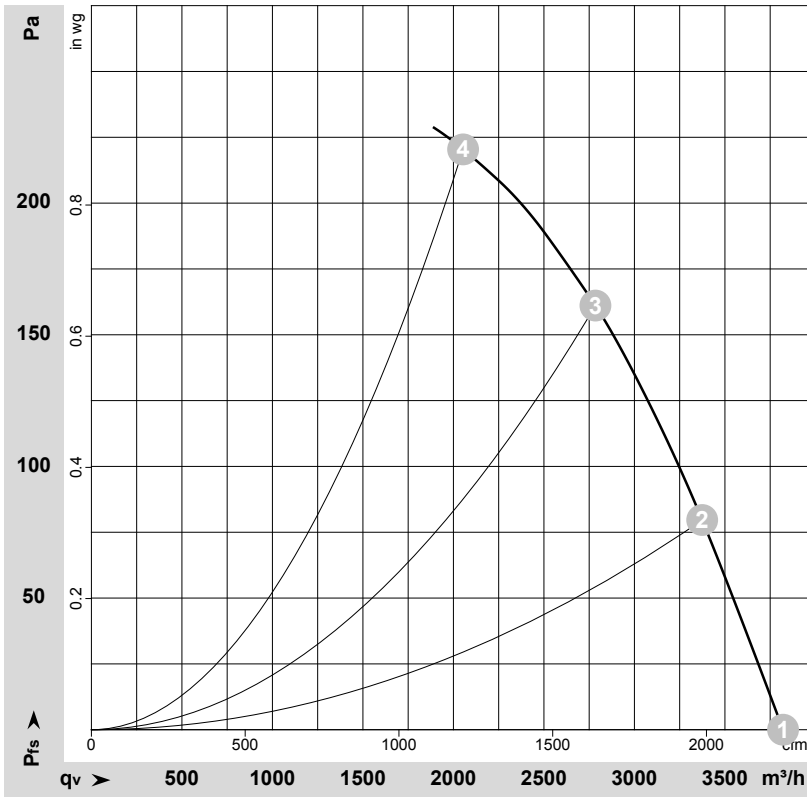

$\rho = 1.15 \text{ kg/m}^3 \pm 2 \%$

Measurement: LU-39002-1

Air performance measured according to ISO 5801 installation category A. For detailed information on the measurement setup, contact ebmpapst. Intake sound level: Sound power level according to ISO 13347 / sound pressure level measured at 1 m distance from fan axis. The values given are valid under the specified measuring conditions and may vary due to conditions of installation. For deviations from the standard configuration, the parameters have to be checked on the installed unit.

Measured values

	U	f	n	P _e	I	qv	p _{fs}	qv	p _{fs}
	V	Hz	min ⁻¹	W	A	m ³ /h	Pa	CFM	inH ₂ O
1	230	50	2800	280	1.23	3820	0	2250	0.00
2	230	50	2765	310	1.36	3375	80	1985	0.32
3	230	50	2720	344	1.50	2785	160	1640	0.64
4	230	50	2665	380	1.65	2055	220	1210	0.88

U = Power supply · f = Frequency · n = Speed (rpm) · P_e = Power consumption · I = Current draw · qv = Air flow · p_{fs} = Pressure increase



Curves: Air performance 60 Hz

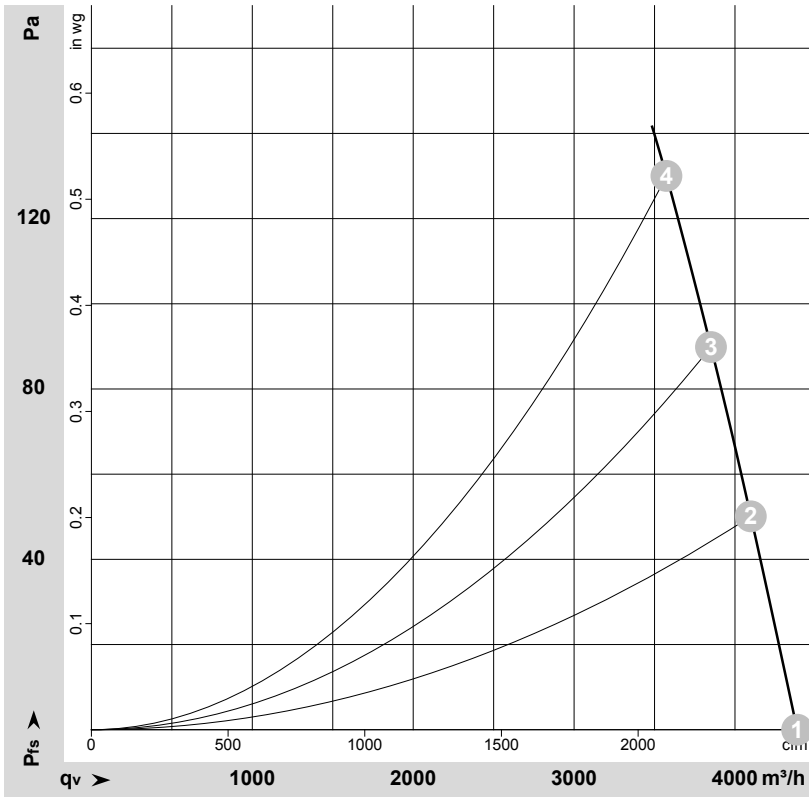

$\rho = 1.15 \text{ kg/m}^3 \pm 2 \%$

Measurement: LU-39003-1

Air performance measured according to ISO 5801 installation category A. For detailed information on the measurement setup, contact ebmpapst. Intake sound level: Sound power level according to ISO 13347 / sound pressure level measured at 1 m distance from fan axis. The values given are valid under the specified measuring conditions and may vary due to conditions of installation. For deviations from the standard configuration, the parameters have to be checked on the installed unit.

Measured values

	U	f	n	P _e	I	qv	p _{fs}	qv	p _{fs}
	V	Hz	min ⁻¹	W	A	m ³ /h	Pa	CFM	inH ₂ O
1	230	60	3200	435	1.93	4385	0	2580	0.00
2	230	60	3150	453	2.01	4100	50	2410	0.20
3	230	60	3105	472	2.07	3850	90	2265	0.36
4	230	60	3050	488	2.14	3575	130	2105	0.52

U = Power supply · f = Frequency · n = Speed (rpm) · P_e = Power consumption · I = Current draw · qv = Air flow · p_{fs} = Pressure increase

