

A2E250-AM06-17 ebmpapst Datasheet

sales@fansco.com

www.fansco.com

Limited partnership · Headquarters Mulfingen

Amtsgericht (court of registration) Stuttgart · HRA 590344

General partner Elektrobau Mulfingen GmbH · Headquarters Mulfingen

Amtsgericht (court of registration) Stuttgart · HRB 590142

Nominal data

Type	A2E250-AM06-17			
Motor	M2E068-CF			
Phase		1~	1~	1~
Nominal voltage	VAC	230	230	230
Frequency	Hz	50	60	60
Method of obtaining data		fa	fa	fa
Valid for approval/standard		CE	CE	UL 2111
Speed (rpm)	min ⁻¹	2450	2600	2600
Power consumption	W	115	150	165
Current draw	A	0.51	0.66	0.70
Capacitor	µF	3	3	3
Capacitor voltage	VDB	400	400	400
Capacitor standard		S0 (CE)	S0 (CE)	UL
Max. back pressure	Pa	120	85	85
Max. back pressure	inH ₂ O	0.48	0.34	0.34
Max. ambient temperature	°C	65	50	50
Starting current	A	0.88	0.87	

ml = Max. load · me = Max. efficiency · fa = Free air · cs = Customer specification · ce = Customer equipment
Subject to change



Technical description

Fan size	250 mm
Rotor surface	Painted black
Blade material	Sheet steel, painted black
Number of blades	9
Airflow direction	"A"
Direction of rotation	Counterclockwise, viewed toward rotor
Degree of protection	IP44
Insulation class	"B"
Moisture (F) / Environmental (H) protection class	H0+
Max. permitted ambient temp. for motor (transport/storage)	+ 80 °C
Min. permitted ambient temp. for motor (transport/storage)	- 40 °C
Installation position	Any
Condensation drainage holes	On rotor side
Mode	S1
Motor bearing	Ball bearing
Touch current according to IEC 60990 (measuring circuit Fig. 4, TN system)	< 0.75 mA
Motor protection	Thermal overload protector (TOP) internally connected
With cable	Variable
Protection class	I (with customer connection of protective earth)
Conformity with standards	EN 60335-1; CE
Approval	UL 2111; CSA C22.2 No. 77

AC axial fan

sickle-shaped blades (S series)

Product drawing

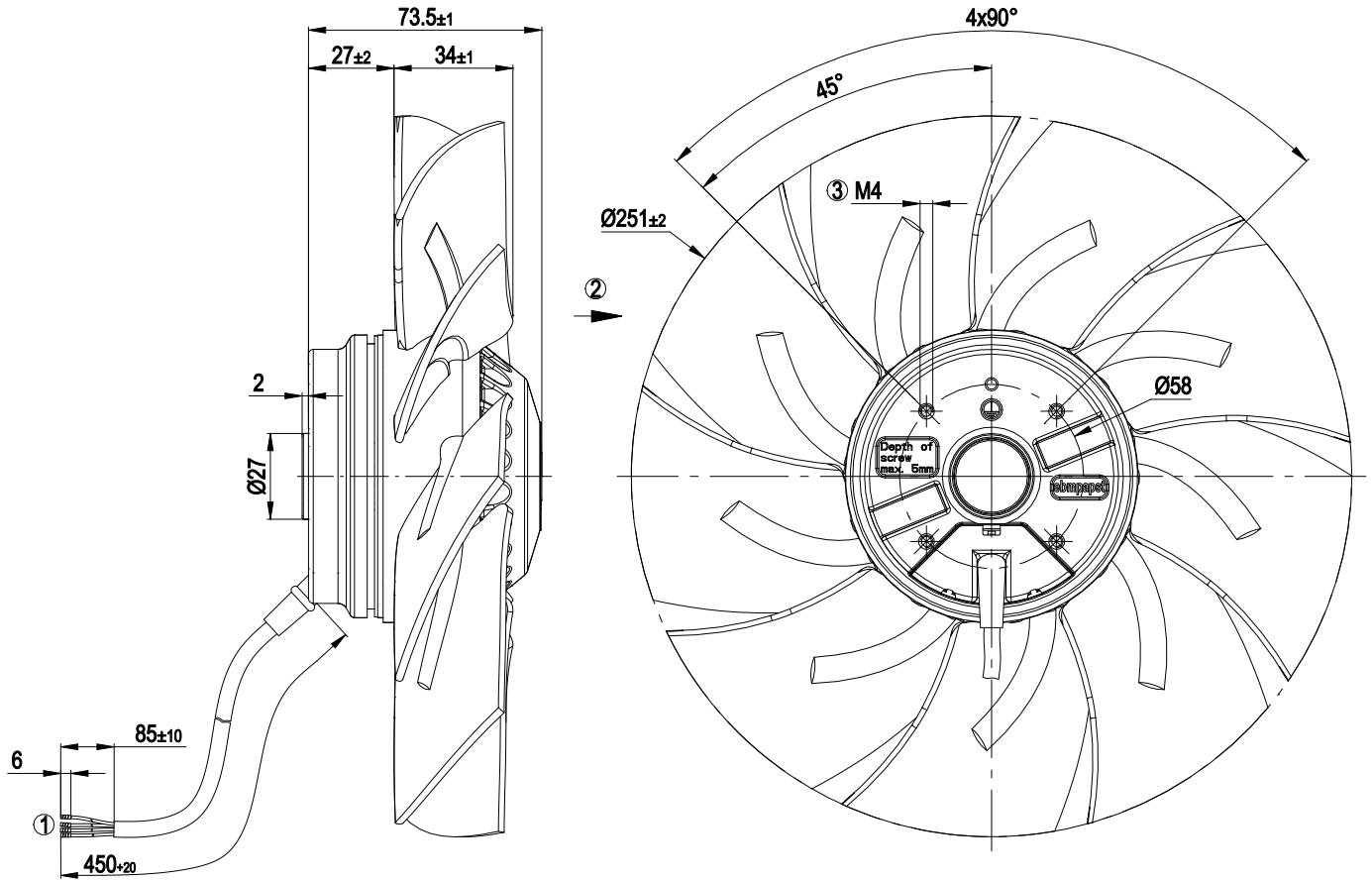

1	Cable PVC, crimped splices
2	Direction of air flow "A"
3	Max. clearance for screw 5 mm

Connection diagram

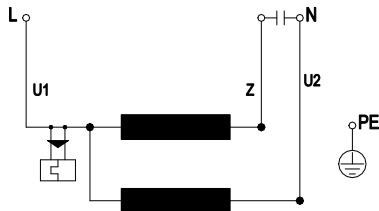

U1	blue	Z	brown	U2	black
PE	green/yellow				



Curves: Air performance 50 Hz

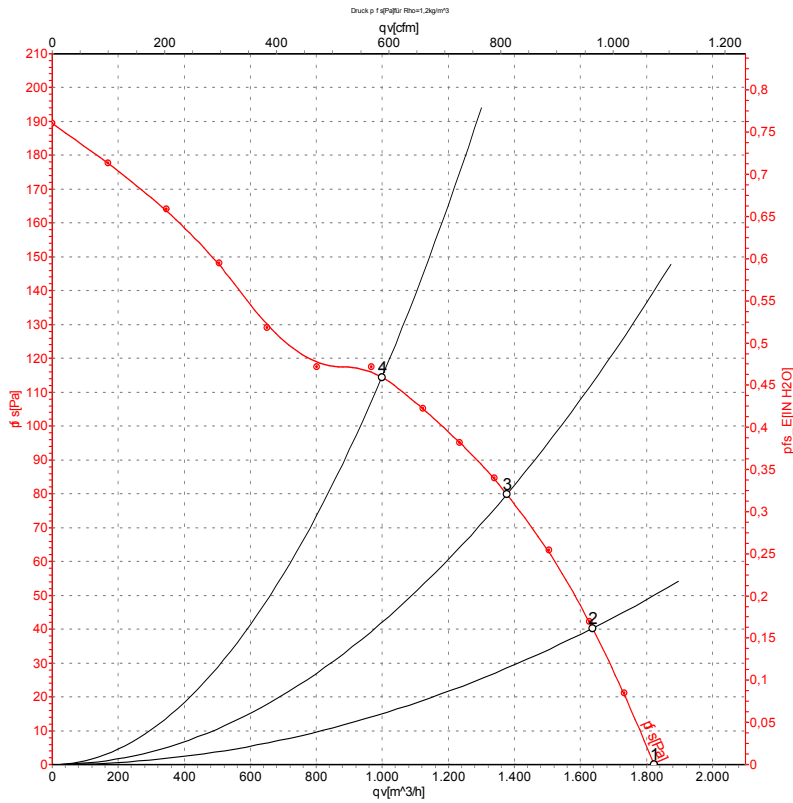

Measurement: LU-59608-1

Air performance measured according to ISO 5801 installation category A. For detailed information on the measurement setup, contact ebm-papst. Intake sound level: Sound power level according to ISO 13347 / sound pressure level measured at 1 m distance from fan axis. The values given are valid under the specified measuring conditions and may vary due to conditions of installation. For deviations from the standard configuration, the parameters have to be checked on the installed unit.

Measured values

	U	f	n	P _e	I	q _v	p _{fs}	q _v	p _{fs}
	V	Hz	min ⁻¹	W	A	m³/h	Pa	cfm	inH2O
1	230	50	2450	115	0.51	1820	0	1070	0.00
2	230	50	2420	120	0.52	1635	40	965	0.16
3	230	50	2335	125	0.56	1375	80	810	0.32
4	230	50	2270	134	0.58	1000	115	585	0.46

U = Power supply · f = Frequency · n = Speed (rpm) · P_e = Power consumption · I = Current draw · q_v = Air flow · p_{fs} = Pressure increase



Curves: Air performance 60 Hz

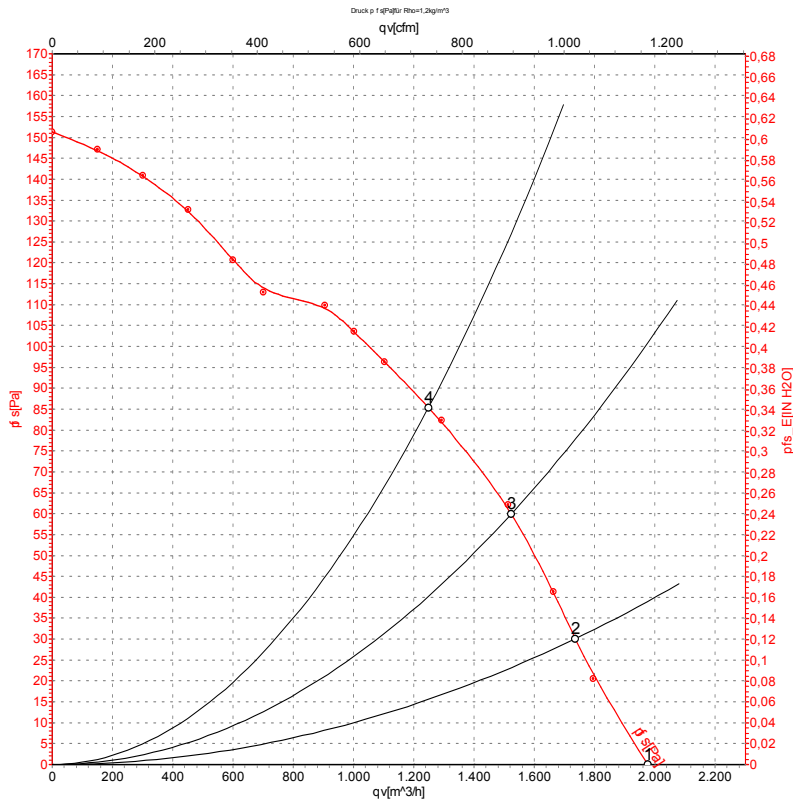

Measurement: LU-59609-1

Air performance measured according to ISO 5801 installation category A. For detailed information on the measurement setup, contact ebmpapst. Intake sound level: Sound power level according to ISO 13347 / sound pressure level measured at 1 m distance from fan axis. The values given are valid under the specified measuring conditions and may vary due to conditions of installation. For deviations from the standard configuration, the parameters have to be checked on the installed unit.

Measured values

	U	f	n	P _e	I	q _v	P _{fs}	q _v	P _{fs}
	V	Hz	min ⁻¹	W	A	m ³ /h	Pa	cfm	inH2O
1	230	60	2600	150	0.66	1970	0	1160	0.00
2	230	60	2525	156	0.68	1735	30	1020	0.12
3	230	60	2415	160	0.70	1525	60	895	0.24
4	230	60	2300	164	0.71	1250	85	735	0.34

U = Power supply · f = Frequency · n = Speed (rpm) · P_e = Power consumption · I = Current draw · q_v = Air flow · P_{fs} = Pressure increase

