

# AC axial fan

sickled blades (S series)

A2E250-AL06-14 ebmpapst Datasheet  
 sales@fansco.com  
 www.fansco.com

Limited partnership · Headquarters Muldingen  
 County court Stuttgart · HRA 590344

General partner Elektrobau Muldingen GmbH · Headquarters Muldingen  
 County court Stuttgart · HRB 590142

## Nominal data

<b>Type</b>	<b>A2E250-AL06-14</b>		
<b>Motor</b>	<b>M2E068-CF</b>		
Phase		1~	1~
Nominal voltage	VAC	230	230
Frequency	Hz	50	60
Type of data definition		fa	fa
Valid for approval / standard		CE	CE
Speed	min <sup>-1</sup>	2450	2600
Power input	W	115	150
Current draw	A	0.51	0.66
Motor capacitor	µF	3	3
Capacitor voltage	VDB	400	400
Capacitor standard		P0 (CE)	P0 (CE)
Max. back pressure	Pa	120	85
Min. ambient temperature	°C	-25	-25
Max. ambient temperature	°C	65	50
Starting current	A	0.88	0.87

ml = max. load · me = max. efficiency · fa = running at free air · cs = customer specs · cu = customer unit  
 Subject to alterations



# AC axial fan

sickled blades (S series)

## Technical features

Size	250 mm
Surface of rotor	Coated in black
Material of blades	Sheet steel, coated in black
Number of blades	7
Direction of air flow	"V"
Direction of rotation	Counter-clockwise, seen on rotor
Type of protection	IP 44; Depending on installation and position
Insulation class	"B"
Humidity class	F0
Max. permissible ambient motor temp. (transp./ storage)	+ 80 °C
Min. permissible ambient motor temp. (transp./storage)	- 40 °C
Mounting position	Any
Condensate discharge holes	None
Operation mode	S1
Motor bearing	Ball bearing
Touch current acc. IEC 60990 (measuring network Fig. 4, TN system)	< 0.75 mA
Motor protection	Thermal overload protector (TOP) wired internally
Cable exit	Variable
Protection class	I (if protective earth is connected by customer)
Product conforming to standard	EN 60335-1; CE



## Product drawing

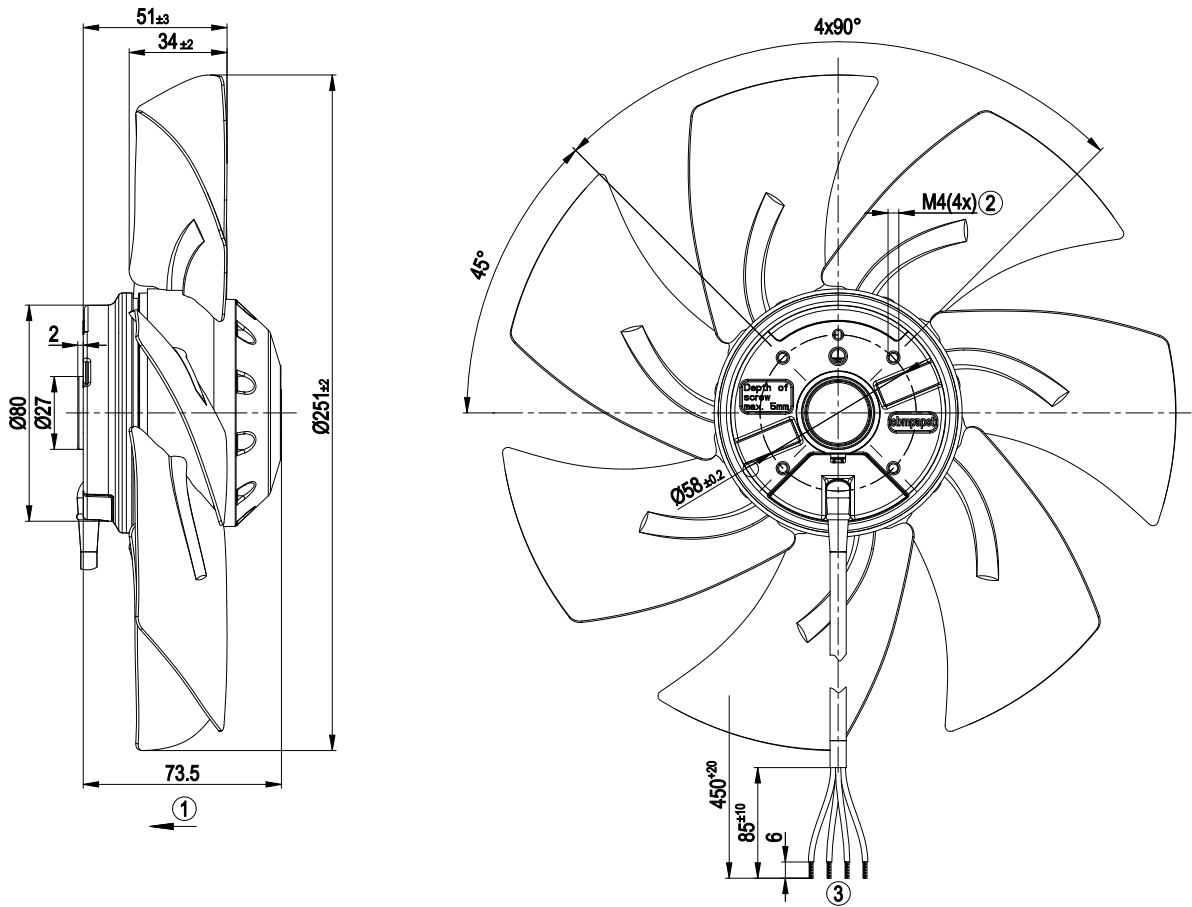

1	Direction of air flow "V"
2	Depth of screw max. 5 mm
3	Connection line PVC 4G 0.5 mm <sup>2</sup> , 4x brass lead tips crimped

## Connection screen

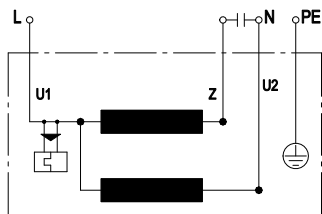

U1	blue	Z	brown	U2	black
PE	green/yellow				



## Charts: Air flow 50 Hz

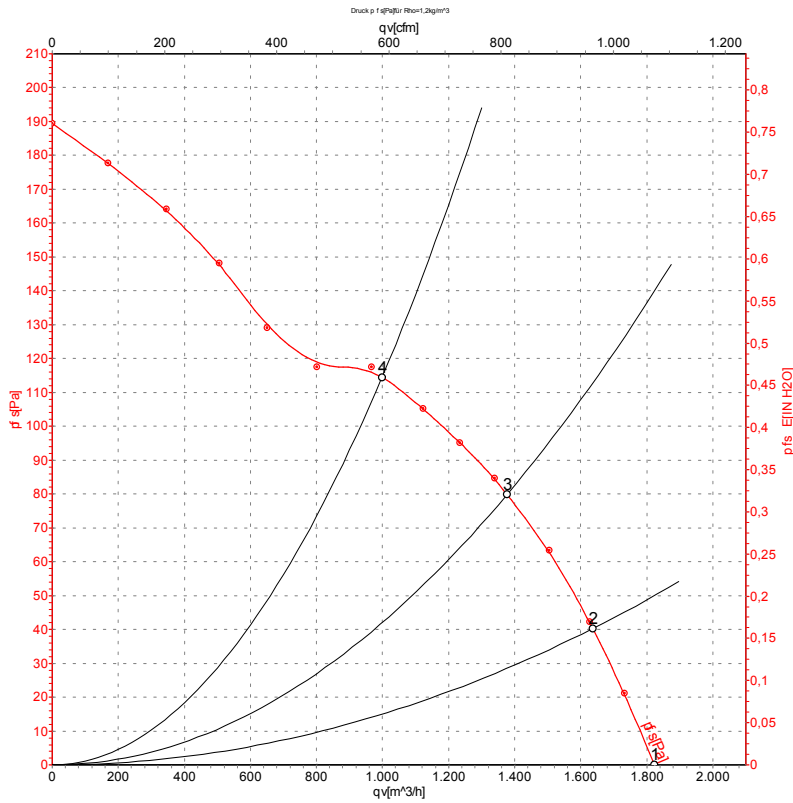

Measurement: LU-59608

Air performance measured as per ISO 5801 Installation category A. For detailed information on the measuring set-up, please contact ebm-papst. Suction-side noise levels: L<sub>wA</sub> measured as per ISO 13347 / L<sub>pA</sub> measured with 1m distance to fan axis. The values given are valid under the measuring conditions mentioned above and may vary according to the actual installation situation. With any deviation from the standard set-up, the specific values have to be checked and reviewed with the unit installed.

## Measured values

	U	f	n	P <sub>e</sub>	I	qv	P <sub>fs</sub>
	V	Hz	min <sup>-1</sup>	W	A	m <sup>3</sup> /h	Pa
1	230	50	2450	115	0.51	1820	0
2	230	50	2420	120	0.52	1635	40
3	230	50	2335	125	0.56	1375	80
4	230	50	2270	134	0.58	1000	115

U = Supply voltage · f = Frequency · n = Speed · P<sub>e</sub> = Power input · I = Current draw · qv = Air flow · P<sub>fs</sub> = Pressure increase



## Charts: Air flow 60 Hz

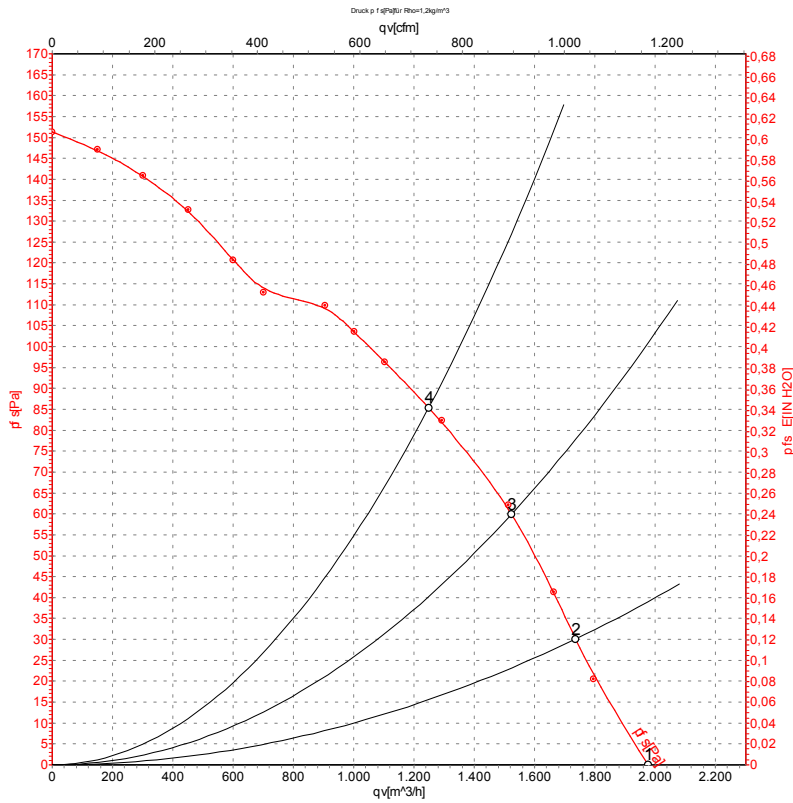

Measurement: LU-59609

Air performance measured as per ISO 5801 Installation category A. For detailed information on the measuring set-up, please contact ebmpapst. Suction-side noise levels: LwA measured as per ISO 13347 / LpA measured with 1m distance to fan axis. The values given are valid under the measuring conditions mentioned above and may vary according to the actual installation situation. With any deviation from the standard set-up, the specific values have to be checked and reviewed with the unit installed.

## Measured values

	U	f	n	P <sub>e</sub>	I	qv	P <sub>fs</sub>
	V	Hz	min <sup>-1</sup>	W	A	m <sup>3</sup> /h	Pa
1	230	60	2600	150	0.66	1970	0
2	230	60	2525	156	0.68	1735	30
3	230	60	2415	160	0.70	1525	60
4	230	60	2300	164	0.71	1250	85

U = Supply voltage · f = Frequency · n = Speed · P<sub>e</sub> = Power input · I = Current draw · qv = Air flow · P<sub>fs</sub> = Pressure increase

