

# AC axial fan

straight blades (A series)



A2E250-AE31-14 ebmpapst Datasheet  
[sales@fansco.com](mailto:sales@fansco.com)  
[www.fansco.com](http://www.fansco.com)

Limited partnership · Headquarters Mulfingen  
 Amtsgericht (court of registration) Stuttgart · HRA 590344

General partner Elektrobau Mulfingen GmbH · Headquarters Mulfingen  
 Amtsgericht (court of registration) Stuttgart · HRB 590142

## Nominal data

Type	A2E250-AE31-14			
Motor	M2E068-DF			
Phase		1~	1~	1~
Nominal voltage	VAC	115	115	115
Frequency	Hz	50	60	60
Method of obtaining data		fa	fa	fa
Valid for approval/standard		CE	CE	UL 2111
Speed (rpm)	min <sup>-1</sup>	2550	2800	2800
Power consumption	W	110	150	155
Current draw	A	0.97	1.32	1.3
Capacitor	µF	12	12	12
Capacitor voltage	VDB	220	220	220
Capacitor standard		S2 (CE)	S2 (CE)	UL
Max. back pressure	Pa	140	140	140
Max. back pressure	inH <sub>2</sub> O	0.56	0.56	0.56
Min. ambient temperature	°C	-25	-25	-25
Max. ambient temperature	°C	70	65	65
Starting current	A	2.0	2.1	2.1

ml = Max. load · me = Max. efficiency · fa = Free air · cs = Customer specification · ce = Customer equipment  
 Subject to change



## Technical description

Weight	2.2 kg
Fan size	250 mm
Rotor surface	Painted black
Blade material	Sheet steel, galvanized
Number of blades	5
Airflow direction	"V"
Direction of rotation	Counterclockwise, viewed toward rotor
Degree of protection	IP44; installation- and position-dependent as per EN 60034-5
Insulation class	"B"
Moisture (F) / Environmental (H) protection class	H0 - dry environment
Max. permitted ambient temp. for motor (transport/storage)	+ 80 °C
Min. permitted ambient temp. for motor (transport/storage)	- 40 °C
Installation position	Shaft horizontal or rotor on bottom; rotor on top on request
Condensation drainage holes	On rotor side
Mode	S1
Motor bearing	Ball bearing
Touch current according to IEC 60990 (measuring circuit Fig. 4, TN system)	< 0.75 mA
Motor protection	Thermal overload protector (TOP) internally connected
With cable	Variable
Protection class	I (with customer connection of protective earth)
Conformity with standards	EN 60335-1; CE
Approval	UL 1004-3; CSA C22.2 No. 77

## Product drawing

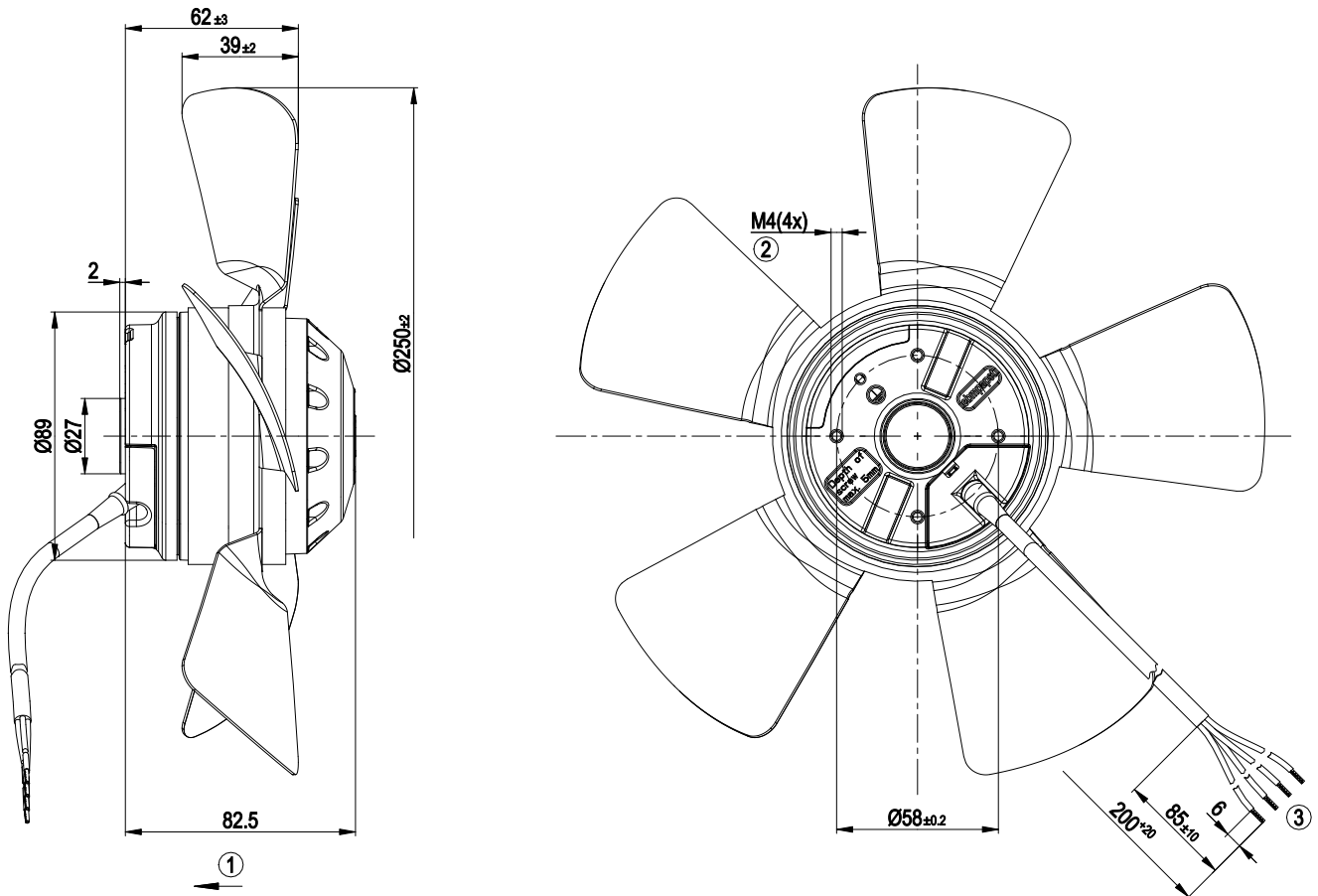

1	Direction of air flow "V"
2	Max. clearance for screw 5 mm
3	Cable PVC 4G AWG20, 4x crimped splices

## Connection diagram

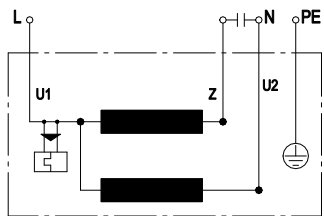

U1	blue	Z	brown	U2	black
PE	green/yellow				



## Curves: Air performance 50 Hz

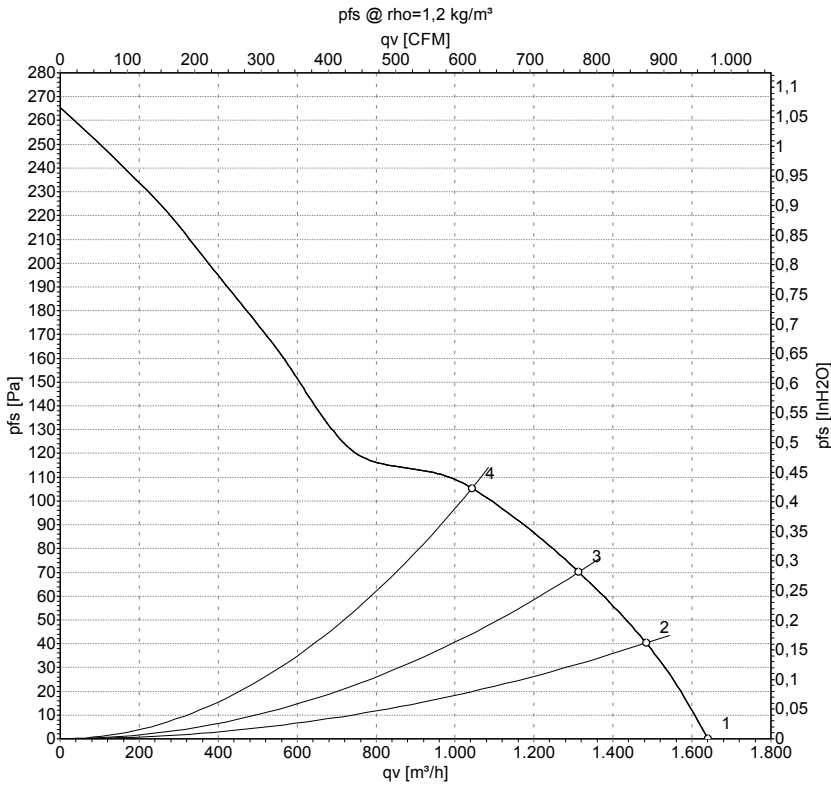

Measurement: LU-56499-1

Air performance measured according to ISO 5801 installation category A. For detailed information on the measurement setup, contact ebm-papst. Intake sound level: Sound power level according to ISO 13347 / sound pressure level measured at 1 m distance from fan axis. The values given are valid under the specified measuring conditions and may vary due to conditions of installation. For deviations from the standard configuration, the parameters have to be checked on the installed unit.

## Measured values

	U	f	n	P <sub>e</sub>	I	q <sub>v</sub>	p <sub>fs</sub>	q <sub>v</sub>	p <sub>fs</sub>
	V	Hz	min <sup>-1</sup>	W	A	m <sup>3</sup> /h	Pa	cfm	inH <sub>2</sub> O
1	115	50	2500	115	1.02	1640	0	965	0.00
2	115	50	2470	119	1.04	1485	40	875	0.16
3	115	50	2440	122	1.07	1315	70	775	0.28
4	115	50	2425	124	1.09	1045	105	615	0.42

U = Power supply · f = Frequency · n = Speed (rpm) · P<sub>e</sub> = Power consumption · I = Current draw · q<sub>v</sub> = Air flow · p<sub>fs</sub> = Pressure increase



## Curves: Air performance 60 Hz

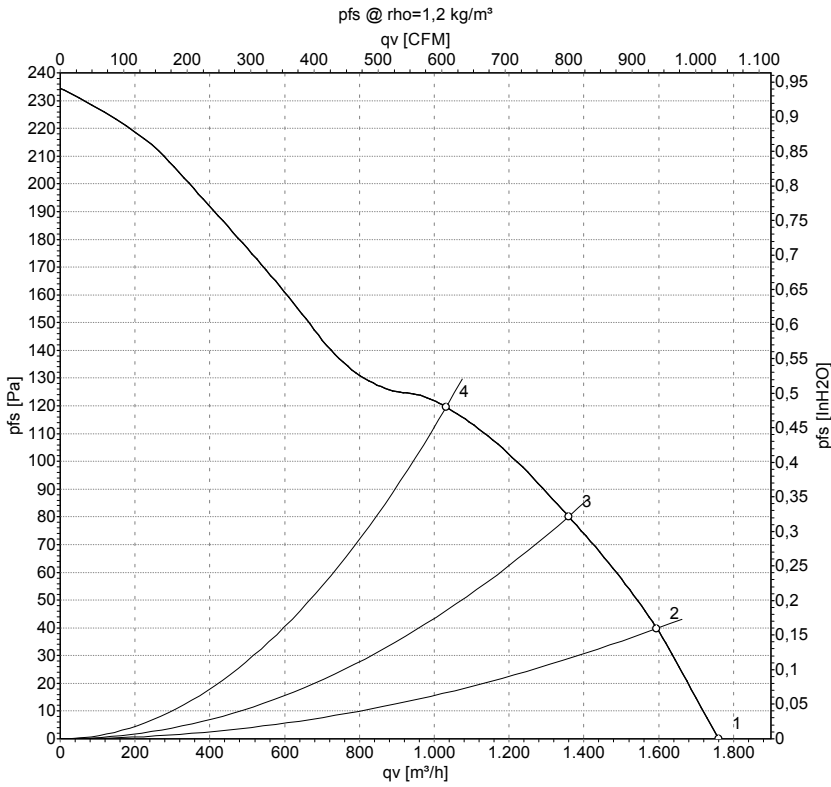

Measurement: LU-56498-1

Air performance measured according to ISO 5801 installation category A. For detailed information on the measurement setup, contact ebm-papst. Intake sound level: Sound power level according to ISO 13347 / sound pressure level measured at 1 m distance from fan axis. The values given are valid under the specified measuring conditions and may vary due to conditions of installation. For deviations from the standard configuration, the parameters have to be checked on the installed unit.

## Measured values

	U	f	n	P <sub>e</sub>	I	q <sub>v</sub>	p <sub>fs</sub>	q <sub>v</sub>	p <sub>fs</sub>
	V	Hz	min <sup>-1</sup>	W	A	m <sup>3</sup> /h	Pa	cfm	inH2O
1	115	60	2690	160	1.40	1760	0	1035	0.00
2	115	60	2620	163	1.42	1595	40	940	0.16
3	115	60	2550	166	1.44	1360	80	800	0.32
4	115	60	2525	166	1.45	1030	120	605	0.48

U = Power supply · f = Frequency · n = Speed (rpm) · P<sub>e</sub> = Power consumption · I = Current draw · q<sub>v</sub> = Air flow · p<sub>fs</sub> = Pressure increase

