

A2E200-AH86-78 ebmpapst Datasheet

sales@fansco.com

www.fansco.com

Limited partnership · Headquarters Muldingen  
County court Stuttgart · HRA 590344

General partner Elektrobau Muldingen GmbH · Headquarters Muldingen  
County court Stuttgart · HRB 590142

## Nominal data

Type	A2E200-AH86-78			
Motor	M2E068-BF			
Phase		1~	1~	1~
Nominal voltage	VAC	115	115	115
Frequency	Hz	50	60	60
Type of data definition		fa	fa	fa
Valid for approval / standard		CE	CE	UL
Speed (rpm)	min <sup>-1</sup>	2500	2700	2700
Power input	W	65	81	85
Current draw	A	0.6	0.7	0.72
Motor capacitor	µF	5	5	5
Capacitor voltage	VDB	220	220	220
Max. back pressure	Pa	90	90	90
Min. ambient temperature	°C	-25	-25	-25
Max. ambient temperature	°C	55	70	70

ml = Max. load · me = Max. efficiency · fa = Running at free air · cs = Customer specs · cu = Customer unit  
Subject to alterations



### Technical features

Mass	1.3 kg
Size	200 mm
Surface of rotor	Coated in black
Material of blades	Sheet steel, coated in black
Number of blades	9
Direction of air flow	"V"
Direction of rotation	Counter-clockwise, seen on rotor
Type of protection	IP 44; Depending on installation and position as per EN 60034-5
Insulation class	"B"
Humidity (F)/environmental protection class (H)	H0+
Max. permissible ambient motor temp. (transp./ storage)	+ 80 °C
Min. permissible ambient motor temp. (transp./storage)	- 40 °C
Mounting position	Shaft horizontal or rotor on top; rotor on bottom on request
Condensate discharge holes	On the stator side
Operation mode	S1
Motor bearing	Ball bearing
Touch current acc. IEC 60990 (measuring network Fig. 4, TN system)	< 0.75 mA
Motor protection	Thermal overload protector (TOP) wired internally
Cable exit	Variable
Protection class	I (if protective earth is connected by customer)
Product conforming to standard	EN 60335-1; CE
Approval	UL 1004-3; CSA C22.2 No.77

# AC axial fan

sickled blades (S series), single inlet

## Product drawing

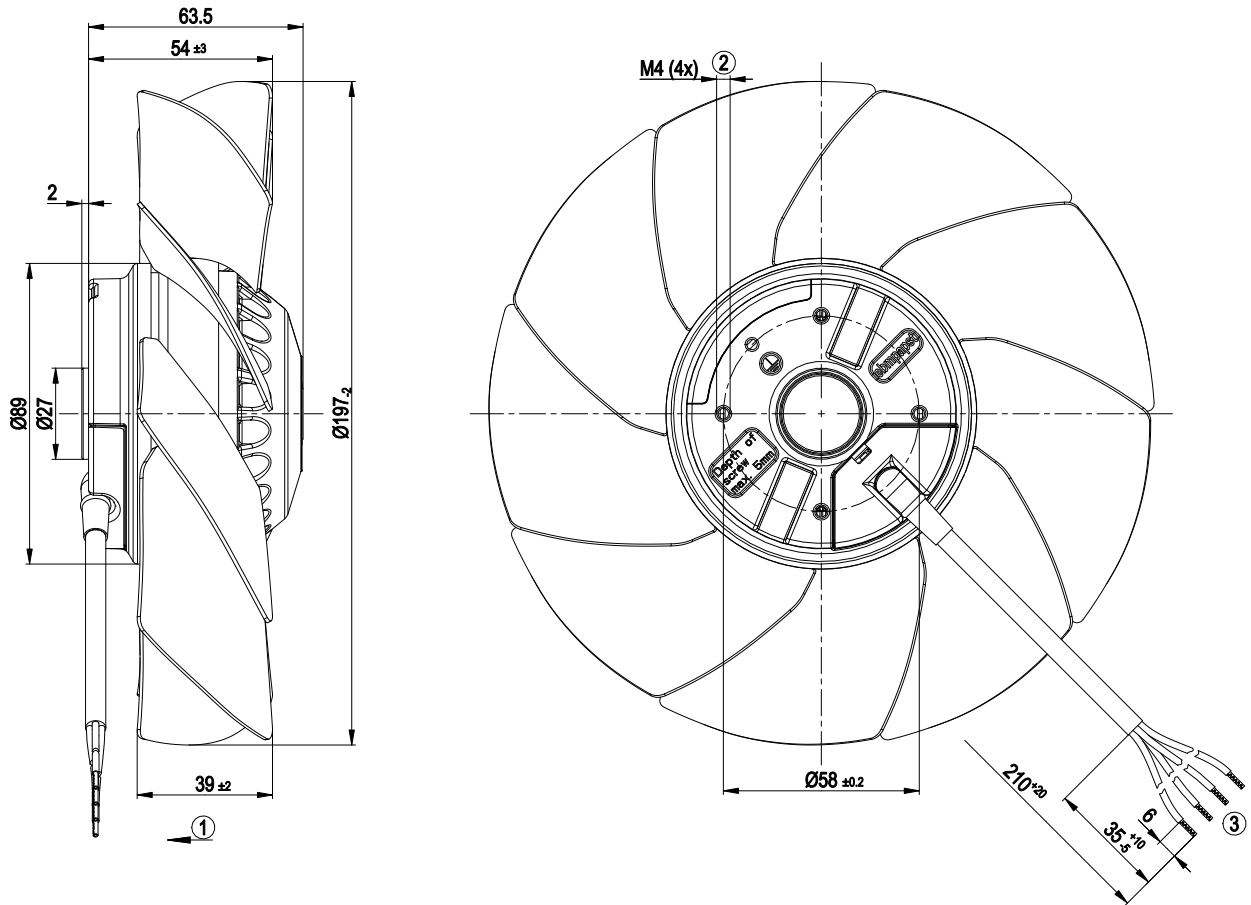

1	Direction of air flow "V"
2	Thread reach max. 5 mm
3	Connection line PVC AWG20, 4x lead tips crimped

## Connection screen

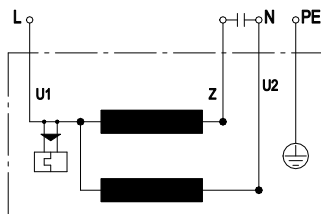

U1	blue	Z	brown	U2	black
PE	green/yellow				



## Charts: Air flow 50 Hz

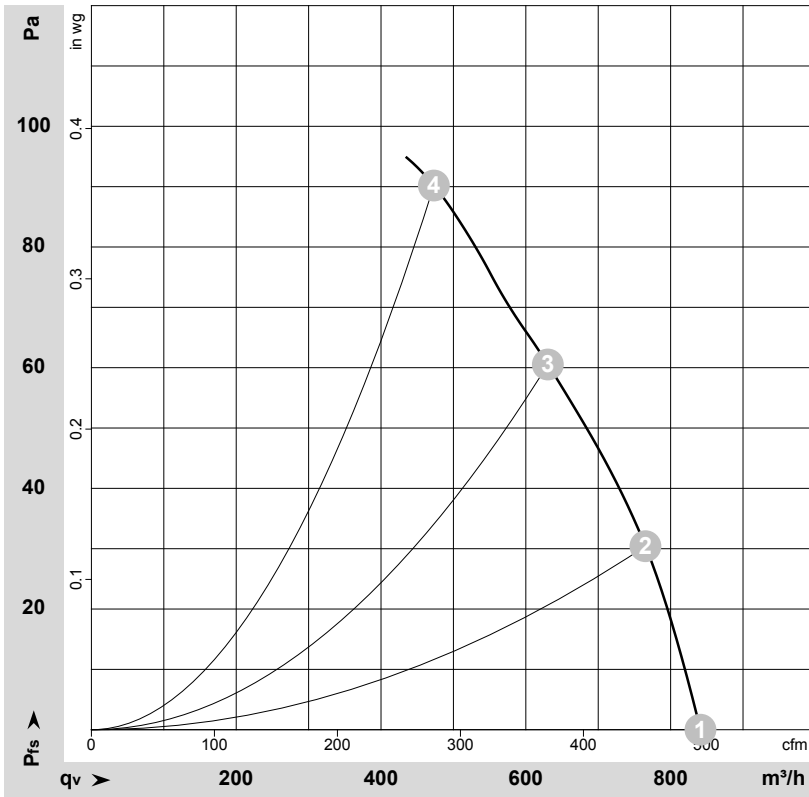

$\rho = 1.15 \text{ kg/m}^3 \pm 2 \%$

Measurement: LU-33654-1

Air performance measured as per ISO 5801 Installation category A. For detailed information on the measuring set-up, please contact ebmpapst. Suction-side noise levels: LwA measured as per ISO 13347 / LpA measured with 1m distance to fan axis. The values given are valid under the measuring conditions mentioned above and may vary according to the actual installation situation. With any deviation from the standard set-up, the specific values have to be checked and reviewed with the unit installed.

## Measured values

	U	f	n	P <sub>e</sub>	I	q <sub>v</sub>	P <sub>fs</sub>	q <sub>v</sub>	P <sub>fs</sub>
	V	Hz	min <sup>-1</sup>	W	A	m <sup>3</sup> /h	Pa	cfm	inH <sub>2</sub> O
1	115	50	2500	65	0.60	840	0	495	0.00
2	115	50	2450	68	0.62	765	30	450	0.12
3	115	50	2390	71	0.64	630	60	370	0.24
4	115	50	2350	72	0.65	475	90	280	0.36

U = Supply voltage · f = Frequency · n = Speed (rpm) · P<sub>e</sub> = Power input · I = Current draw · q<sub>v</sub> = Air flow · P<sub>fs</sub> = Pressure increase



## Charts: Air flow 60 Hz

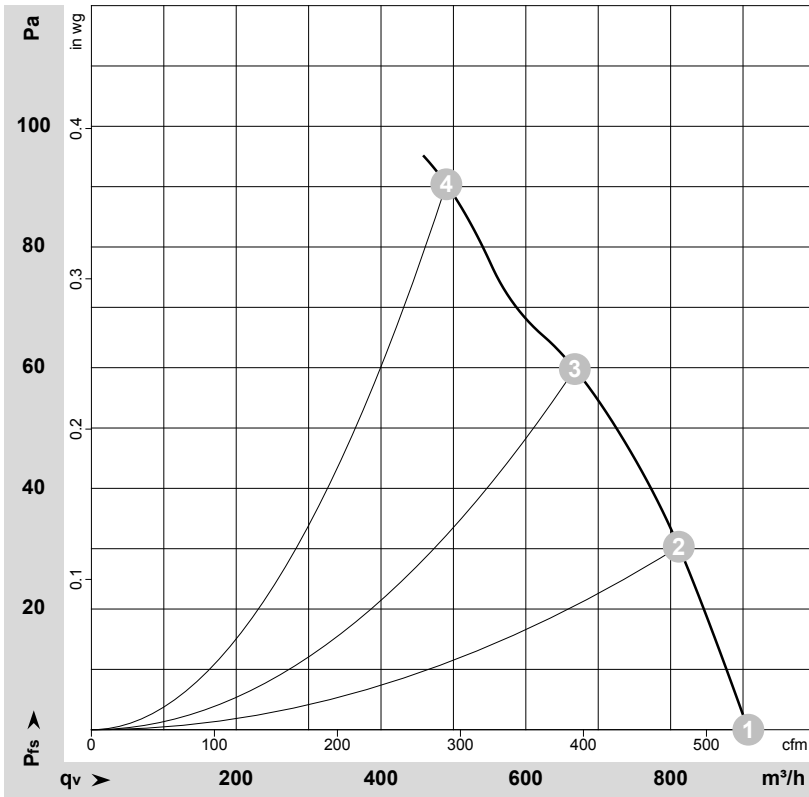

$\rho = 1.15 \text{ kg/m}^3 \pm 2 \%$

Measurement: LU-33655-1

Air performance measured as per ISO 5801 Installation category A. For detailed information on the measuring set-up, please contact ebmpapst. Suction-side noise levels: LwA measured as per ISO 13347 / LpA measured with 1m distance to fan axis. The values given are valid under the measuring conditions mentioned above and may vary according to the actual installation situation. With any deviation from the standard set-up, the specific values have to be checked and reviewed with the unit installed.

## Measured values

	U	f	n	P <sub>e</sub>	I	q <sub>v</sub>	p <sub>fs</sub>	q <sub>v</sub>	p <sub>fs</sub>
	V	Hz	min <sup>-1</sup>	W	A	m <sup>3</sup> /h	Pa	cfm	inH2O
1	115	60	2700	81	0.70	905	0	535	0.00
2	115	60	2570	85	0.74	810	30	475	0.12
3	115	60	2450	88	0.77	670	60	395	0.24
4	115	60	2370	90	0.78	490	90	290	0.36

U = Supply voltage · f = Frequency · n = Speed (rpm) · P<sub>e</sub> = Power input · I = Current draw · q<sub>v</sub> = Air flow · p<sub>fs</sub> = Pressure increase

