

A2E200-AF02-19 ebmpapst Datasheet

sales@fansco.com

www.fansco.com

Nominal data

Type	A2E200-AF02-19		
Motor	M2E068-CA		
Phase		1~	1~
Nominal voltage	VAC	240	240
Frequency	Hz	50	60
Method of obtaining data		fa	fa
Valid for approval/standard		CE	CE
Speed (rpm)	min ⁻¹	2700	3050
Power consumption	W	60	76
Current draw	A	0.26	0.32
Capacitor	µF	1.5	1.5
Capacitor voltage	VDB	400	400
Capacitor standard		S0 (CE)	S0 (CE)
Max. back pressure	Pa	80	100
Max. back pressure	in. wg	0.32	0.4
Min. ambient temperature	°C	-25	-25
Max. ambient temperature	°C	95	95
Starting current	A	0.6	0.57

ml = Max. load · me = Max. efficiency · fa = Free air · cs = Customer specification · ce = Customer equipment
Subject to change



Technical description

Weight	1.4 kg
Fan size	200 mm
Rotor surface	Painted black
Blade material	Sheet steel, painted black
Number of blades	5
Airflow direction	"V"
Direction of rotation	Counterclockwise, viewed toward rotor
Degree of protection	IP44; installation- and position-dependent
Insulation class	"F"
Moisture (F) / Environmental (H) protection class	H0 - dry environment
Max. permitted ambient temp. for motor (transport/storage)	+ 80 °C
Min. permitted ambient temp. for motor (transport/storage)	- 40 °C
Installation position	Any
Condensation drainage holes	None
Mode	S1
Motor bearing	Ball bearing
Touch current according to IEC 60990 (measuring circuit Fig. 4, TN system)	< 0.75 mA
Motor protection	Thermal overload protector (TOP) internally connected
With cable	Variable
Protection class	I (with customer connection of protective earth)
Conformity with standards	EN 60335-1; CE

Product drawing

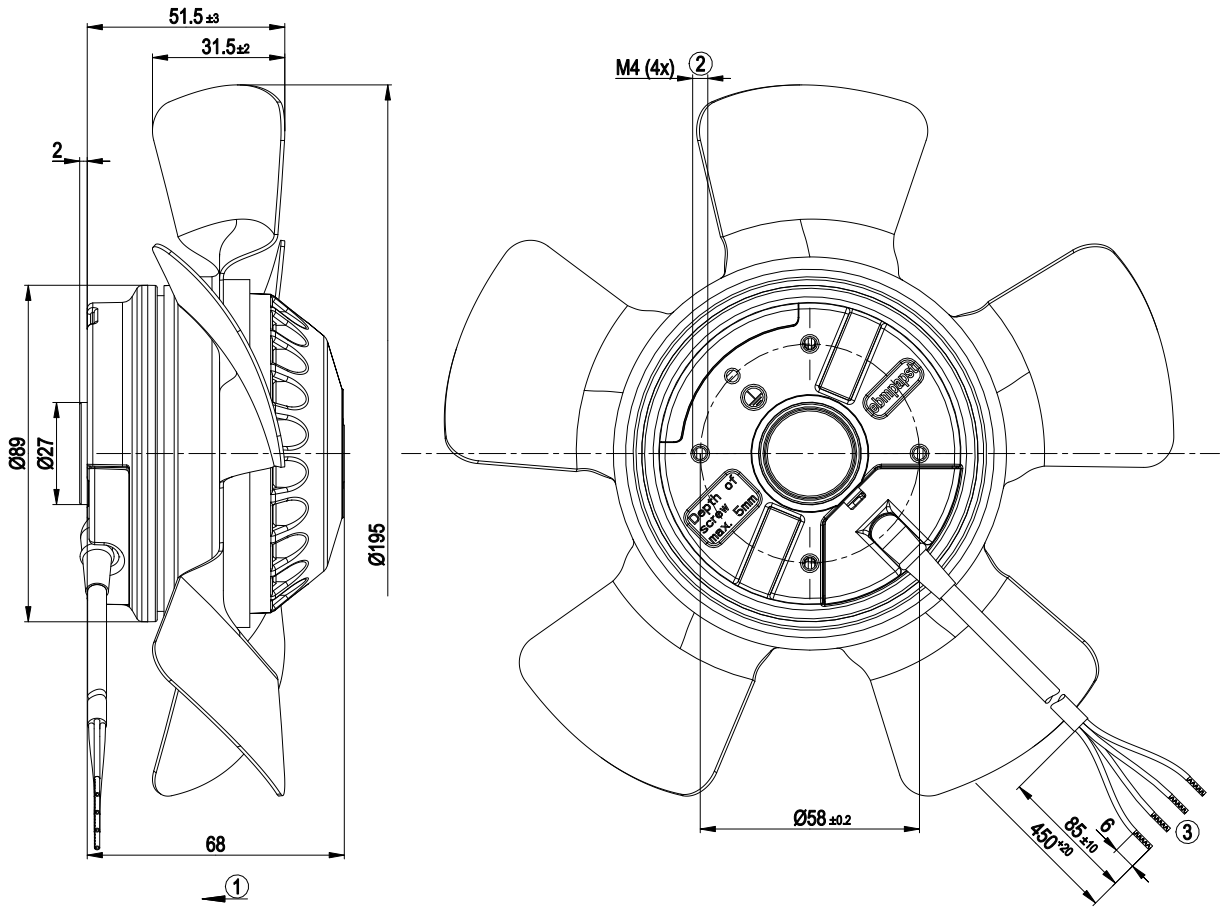

1	Direction of air flow "V"
2	Max. clearance for screw 5 mm
3	Cable silicone 4G 0.5 mm ² , 4x crimped splices

Connection diagram

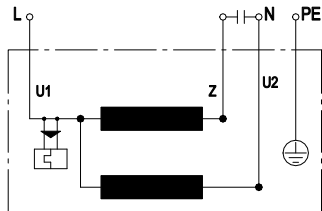

U1	blue	Z	brown	U2	black
PE	green/yellow				

Curves: Air performance 50 Hz

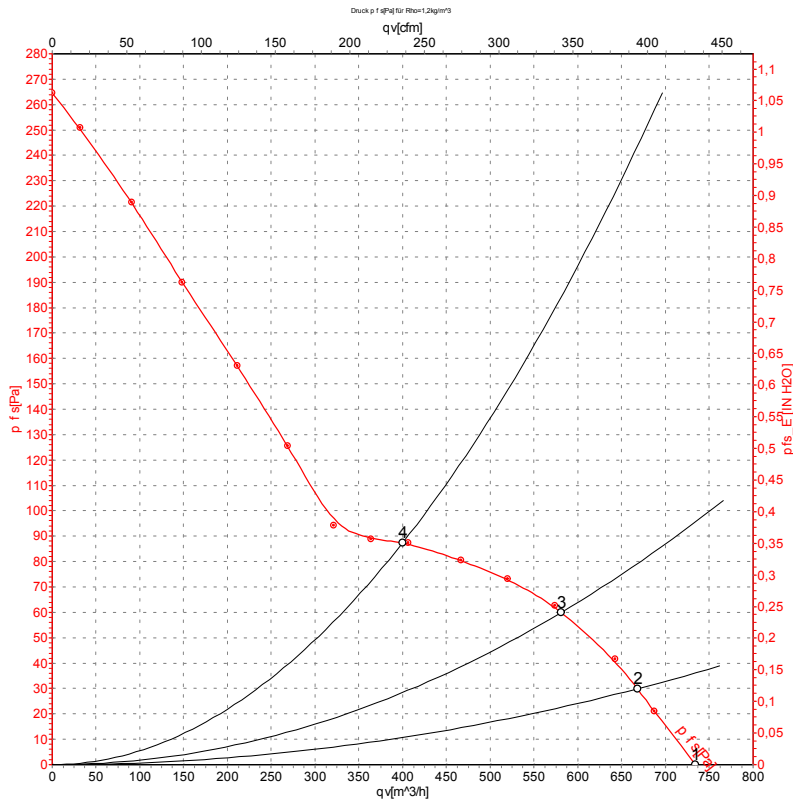

Measurement: LU-57279-1

Air performance measured according to ISO 5801 installation category A. For detailed information on the measurement setup, contact ebmpapst. Intake sound level: Sound power level according to ISO 13347 / sound pressure level measured at 1 m distance from fan axis. The values given are valid under the specified measuring conditions and may vary due to conditions of installation. For deviations from the standard configuration, the parameters have to be checked on the installed unit.

Measured values

	U	f	n	P _e	I	q _v	P _{fs}	q _v	P _{fs}
	V	Hz	min ⁻¹	W	A	m ³ /h	Pa	cfm	in. wg
1	230	50	2740	50	0.24	740	0	435	0.00
2	230	50	2685	50	0.24	670	30	395	0.12
3	230	50	2665	52	0.24	580	60	340	0.24
4	230	50	2680	51	0.24	400	88	235	0.35

U = Power supply · f = Frequency · n = Speed (rpm) · P_e = Power consumption · I = Current draw · q_v = Air flow · P_{fs} = Pressure increase



Curves: Air performance 60 Hz

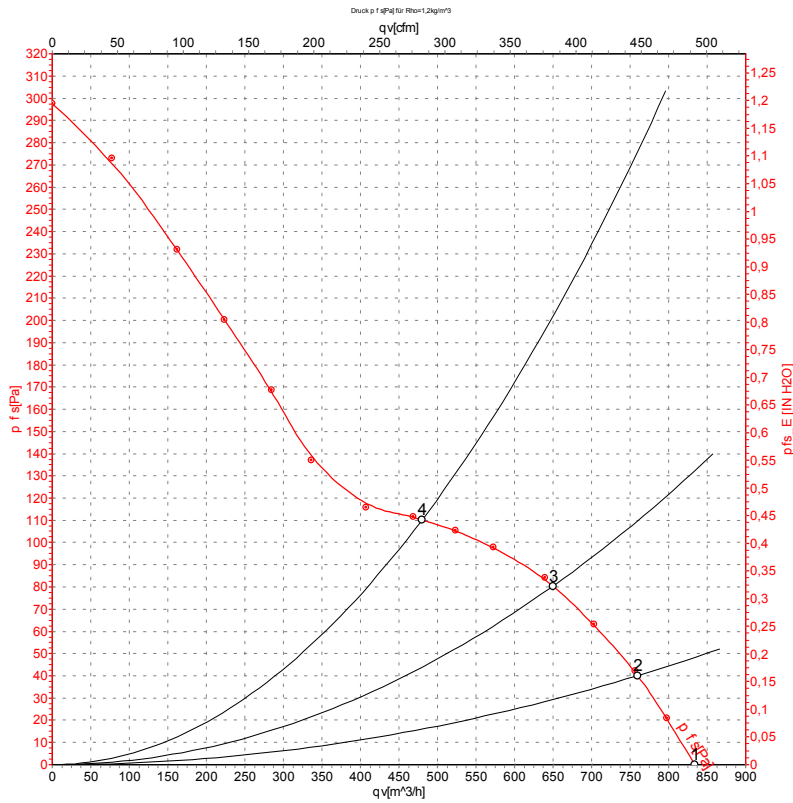

Measurement: LU-57280-1

Air performance measured according to ISO 5801 installation category A. For detailed information on the measurement setup, contact ebmpapst. Intake sound level: Sound power level according to ISO 13347 / sound pressure level measured at 1 m distance from fan axis. The values given are valid under the specified measuring conditions and may vary due to conditions of installation. For deviations from the standard configuration, the parameters have to be checked on the installed unit.

Measured values

	U	f	n	Pe	I	qv	pfs	qv	pfs
	V	Hz	min ⁻¹	W	A	m ³ /h	Pa	cfm	in. wg
1	230	60	3120	61	0.28	830	0	490	0.00
2	230	60	3045	65	0.28	760	40	445	0.16
3	230	60	3005	68	0.29	650	80	385	0.32
4	230	60	3035	66	0.29	480	110	285	0.44

U = Power supply · f = Frequency · n = Speed (rpm) · Pe = Power consumption · I = Current draw · qv = Air flow · pfs = Pressure increase

