

A2D300-AQ01-06 ebmpapst Datasheet

sales@fansco.com

www.fansco.com

Limited partnership · Headquarters Mulfingen

Amtsgericht (court of registration) Stuttgart · HRA 590344

General partner Elektrobau Mulfingen GmbH · Headquarters Mulfingen

Amtsgericht (court of registration) Stuttgart · HRB 590142

## Nominal data

Type	A2D300-AQ01-06			
Motor	M2D074-EI			
Phase		3~	3~	3~
Nominal voltage	VAC	400	400	460
Wiring		Y	Y	Y
Frequency	Hz	50	60	60
Method of obtaining data		ml	ml	ml
Valid for approval/standard		CE	CE	CE
Speed (rpm)	min <sup>-1</sup>	2500	2650	2850
Power consumption	W	260	365	400
Current draw	A	0.45	0.6	0.55
Max. back pressure	Pa	150	170	190
Max. back pressure	in. wg	0.6	0.68	0.76
Min. ambient temperature	°C	-25	-25	-25
Max. ambient temperature	°C	90	70	70
Starting current	A	1.65	1.6	1.95

ml = Max. load · me = Max. efficiency · fa = Free air · cs = Customer specification · ce = Customer equipment  
Subject to change

## Data according to Commission Regulation (EU) 327/2011 (EN 17166)

		Actual	Req. 2015			
01 Overall efficiency $\eta_{es}$	%	33	29.9	09 Power consumption $P_e$	kW	0.25
02 Measurement category		A		09 Air flow $q_v$	m <sup>3</sup> /h	2100
03 Efficiency category		Static		09 Pressure increase $p_{fs}$	Pa	143
04 Efficiency grade N		43.1	40	10 Speed (rpm) n	min <sup>-1</sup>	2515
05 Variable speed drive		No		11 Specific ratio*		1.00

Data obtained at optimum efficiency level.  
The ErP data is determined using a motor-impeller combination in a standardized measurement setup.

\* Specific ratio =  $1 + p_{fs} / 100\,000\text{ Pa}$ 

LU-68886



### Technical description

Weight	3.1 kg
Size	300 mm
Motor size	74
Rotor surface	Painted black
Blade material	Sheet steel, painted black
Number of blades	5
Airflow direction	V
Direction of rotation	Counterclockwise, viewed toward rotor
Degree of protection	IP44; installation- and position-dependent as per EN 60034-5
Insulation class	"F"
Moisture (F) / Environmental (H) protection class	H1
Max. permitted ambient temp. for motor (transport/storage)	+ 80 °C
Min. permitted ambient temp. for motor (transport/storage)	- 40 °C
Installation position	Rotor on top
Condensation drainage holes	On stator side
Mode	S1
Motor bearing	Ball bearing
Touch current according to IEC 60990 (measuring circuit Fig. 4, TN system)	< 0.75 mA
Motor protection	Thermal overload protector (TOP) internally connected
With cable	Variable
Protection class	I (with customer connection of protective earth)
Conformity with standards	EN 60335-1; CE

# AC axial fan

sickle-shaped blades (S series)

## Product drawing

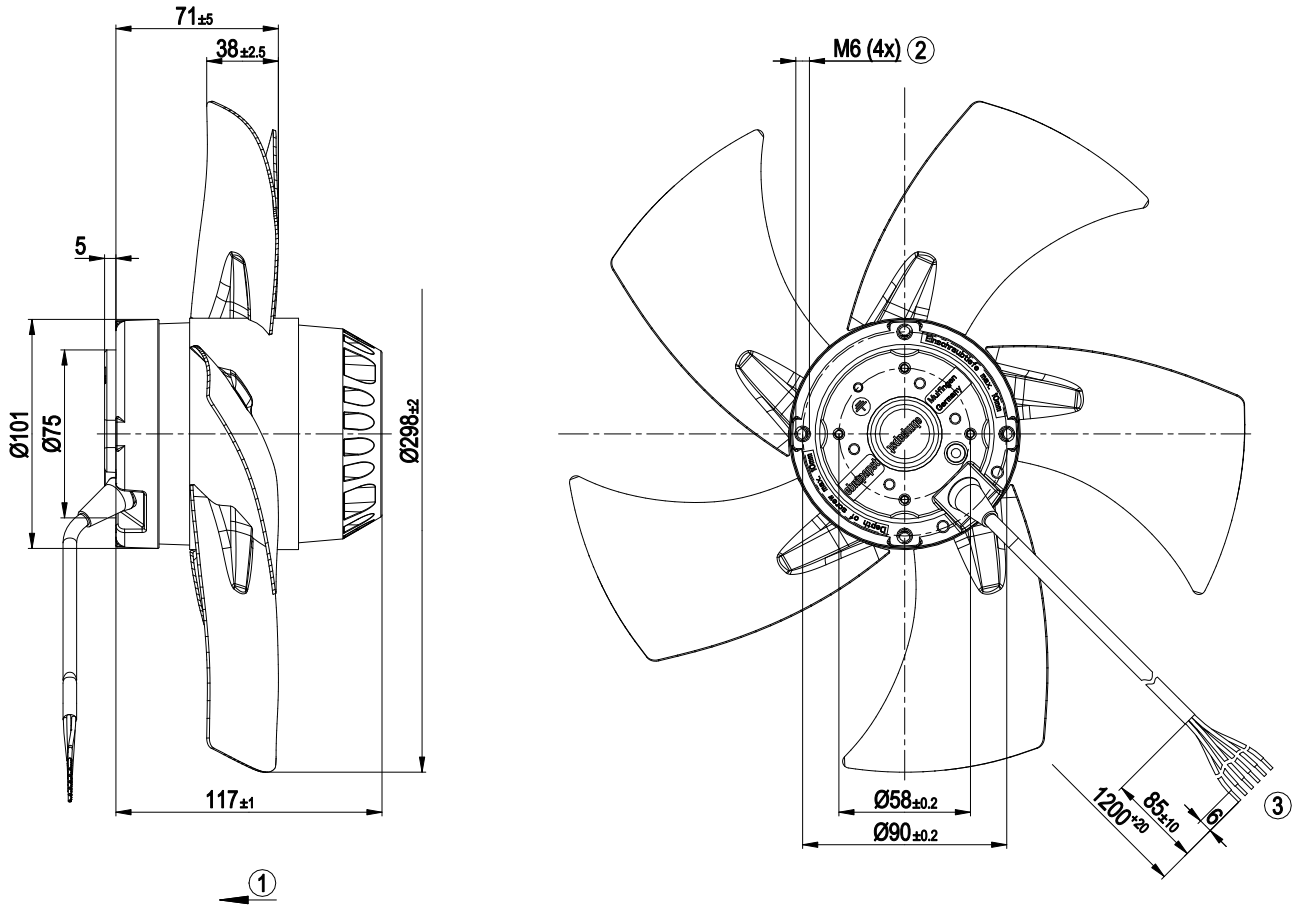

1	Airflow direction "V"
2	Max. clearance for screw 10 mm
3	Cable PFA AWG20 (green/yellow AWG18), 4x crimped splices



## Connection diagram

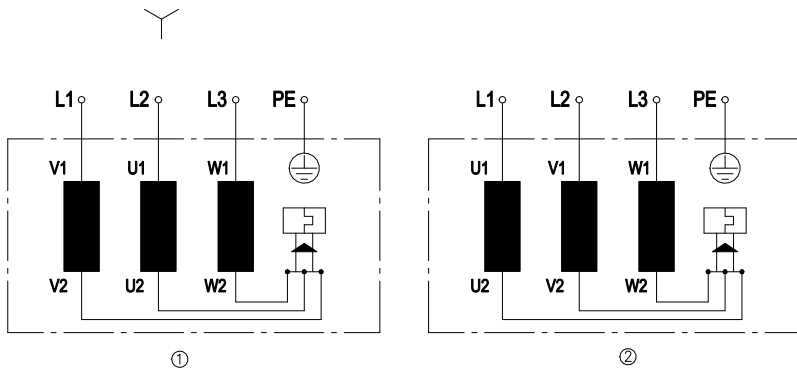

Change of rotation direction by reversing two phases

	Three-phase motor
Y	Star connection
1	Counterclockwise operation
L1	= V1 = blue
L2	= U1 = black
L3	= W1 = brown
2	Clockwise operation
L1	=U1=black
L2	=V1=blue
L3	=W1=brown
PE	green/yellow

## Curves: Air performance 50 Hz

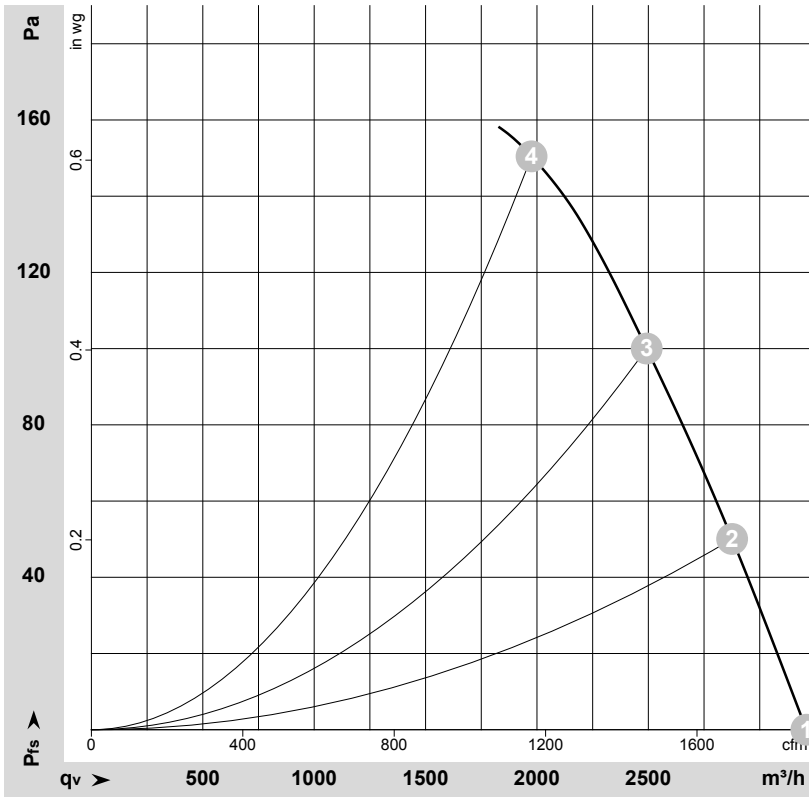

$\rho = 1.15 \text{ kg/m}^3 \pm 2 \%$

Measurement: LU-68886-1

Air performance measured according to ISO 5801 installation category A. For detailed information on the measurement setup, contact ebmpapst. Intake sound level: Sound power level according to ISO 13347 / sound pressure level measured at 1 m distance from fan axis. The values given are valid under the specified measuring conditions and may vary due to conditions of installation. For deviations from the standard configuration, the parameters have to be checked on the installed unit.

## Measured values

	U	f	n	P <sub>e</sub>	I	q <sub>v</sub>	p <sub>fs</sub>	q <sub>v</sub>	p <sub>fs</sub>
	V	Hz	min <sup>-1</sup>	W	A	m <sup>3</sup> /h	Pa	cfm	in. wg
1	400	50	2645	194	0.37	3210	0	1890	0.00
2	400	50	2595	218	0.40	2875	50	1695	0.20
3	400	50	2550	236	0.42	2495	100	1465	0.40
4	400	50	2500	260	0.45	1975	150	1165	0.60

U = Voltage · f = Frequency · n = Speed (rpm) · P<sub>e</sub> = Power consumption · I = Current draw · q<sub>v</sub> = Air flow · p<sub>fs</sub> = Pressure increase

## Curves: Air performance 60 Hz

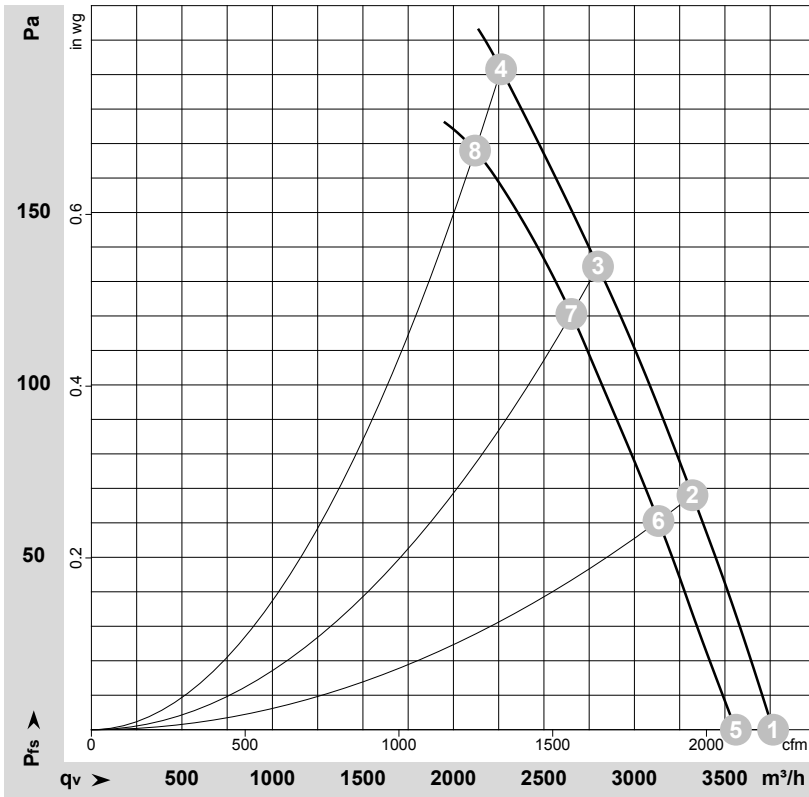

$\rho = 1.15 \text{ kg/m}^3 \pm 2 \%$

Measurement: LU-181718-1  
Measurement: LU-68885-1

Air performance measured according to ISO 5801 installation category A. For detailed information on the measurement setup, contact ebm-papst. Intake sound level: Sound power level according to ISO 13347 / sound pressure level measured at 1 m distance from fan axis. The values given are valid under the specified measuring conditions and may vary due to conditions of installation. For deviations from the standard configuration, the parameters have to be checked on the installed unit.

## Measured values

	Wired	U	f	n	P <sub>e</sub>	I	q <sub>v</sub>	P <sub>fs</sub>	q <sub>v</sub>	P <sub>fs</sub>
		V	Hz	min <sup>-1</sup>	W	A	m <sup>3</sup> /h	Pa	cfm	in. wg
1	Y	460	60	3060	305	0.45	3765	0	2215	0.00
2	Y	460	60	2960	349	0.51	3320	68	1955	0.27
3	Y	460	60	2885	384	0.55	2800	134	1645	0.54
4	Y	460	60	2850	400	0.55	2265	190	1330	0.76
5	Y	400	60	2910	289	0.48	3560	0	2095	0.00
6	Y	400	60	2815	318	0.52	3135	60	1845	0.24
7	Y	400	60	2735	342	0.56	2650	120	1560	0.48
8	Y	400	60	2650	365	0.60	2120	170	1250	0.68

Wired = Wiring · U = Voltage · f = Frequency · n = Speed (rpm) · P<sub>e</sub> = Power consumption · I = Current draw · q<sub>v</sub> = Air flow · p<sub>fs</sub> = Pressure increase

