

A2D300-AP02-28 ebmpapst Datasheet

sales@fansco.com

www.fansco.com

Limited partnership · Headquarters Muldingen
County court Stuttgart · HRA 590344General partner Elektrobau Muldingen GmbH · Headquarters Muldingen
County court Stuttgart · HRB 590142

Nominal data

Type	A2D300-AP02-28				
Motor	M2D074-DF				
Phase		3~	3~	3~	3~
Nominal voltage	VAC	230	230	400	400
Connection		Δ	Δ	Y	Y
Frequency	Hz	50	60	50	60
Type of data definition		fa	fa	fa	fa
Valid for approval / standard		CE	CE	CE	CE
Speed (rpm)	min ⁻¹	2580	2750	2580	2750
Power input	W	210	300	210	300
Current draw	A	0.62	0.84	0.36	0.48
Max. back pressure	Pa	200	125	200	125
Min. ambient temperature	°C	-25	-25	-25	-25
Max. ambient temperature	°C	75	40	75	40
Starting current	A	2.0	1.9	1.16	1.1

ml = Max. load · me = Max. efficiency · fa = Running at free air · cs = Customer specs · cu = Customer unit
Subject to alterations

Data in accordance with ecodesign regulation EU 327/2011

		Actual	Request 2015		
01 Overall efficiency η_{es}	%	32	29.8	09 Power input P_e	kW 0.24
02 Measurement category		A		09 Air flow q_v	m ³ /h 2255
03 Efficiency category		Static		09 Pressure increase p_{fs}	Pa 127
04 Efficiency grade N		42.2	40	10 Speed (rpm) n	min ⁻¹ 2485
05 Variable speed drive		No		11 Specific ratio*	1.00

Data definition with optimum efficiency.
The ErP data is determined using a motor-impeller combination in a standardised measurement configuration.* Specific ratio = $1 + p_g / 100\,000\text{ Pa}$

LU-189127



Technical features

Mass	3.1 kg
Size	300 mm
Motor size	74
Surface of rotor	Coated in black
Material of blades	Sheet steel, coated in black
Number of blades	5
Direction of air flow	A
Direction of rotation	Clockwise, seen on rotor
Type of protection	IP44; Depending on installation and position as per EN 60034-5
Insulation class	"F"
Humidity (F) / environmental protection class (H)	H1+
Max. permissible ambient motor temp. (transp./ storage)	+ 80 °C
Min. permissible ambient motor temp. (transp./storage)	- 40 °C
Mounting position	Shaft horizontal or rotor on top; rotor on bottom on request
Condensation drainage holes	On the stator side
Operation mode	S1
Motor bearing	Ball bearing
Touch current acc. IEC 60990 (measuring network Fig. 4, TN system)	< 0.75 mA
Motor protection	Thermal overload protector (TOP) brought out, basic insulation
Cable exit	Variable
Protection class	I (if protective earth is connected by customer)
Product conforming to standard	EN 60335-1; CE

AC axial fan

sickled blades (S series), single inlet

Product drawing

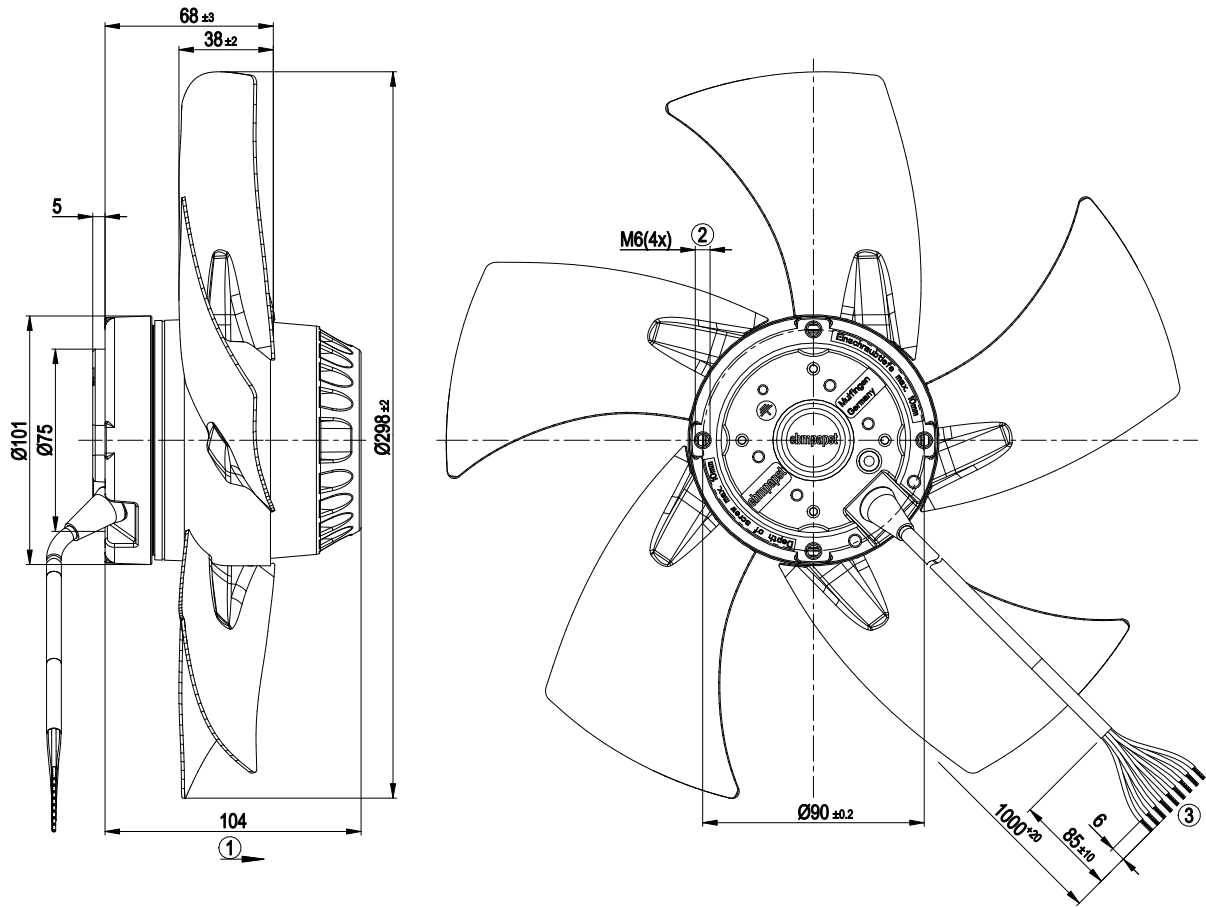

1	Direction of air flow "A"
2	Thread reach max. 10 mm
3	Connection line PFA AWG20 (green/yellow AWG18), 9x lead tips crimped



Connection screen

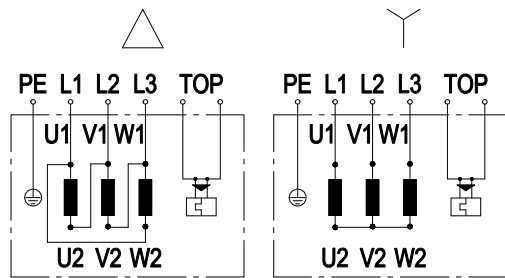

Note: Change in direction of rotation by reversing two phases

Δ	Delta connection	Y	Star connection	L1	black
L2	blue	L3	brown	U1	black
V1	blue	W1	brown	U2	green
V2	white	W2	yellow	TOP	2xgrey
PE	green/yellow				

Charts: Air flow 50 Hz

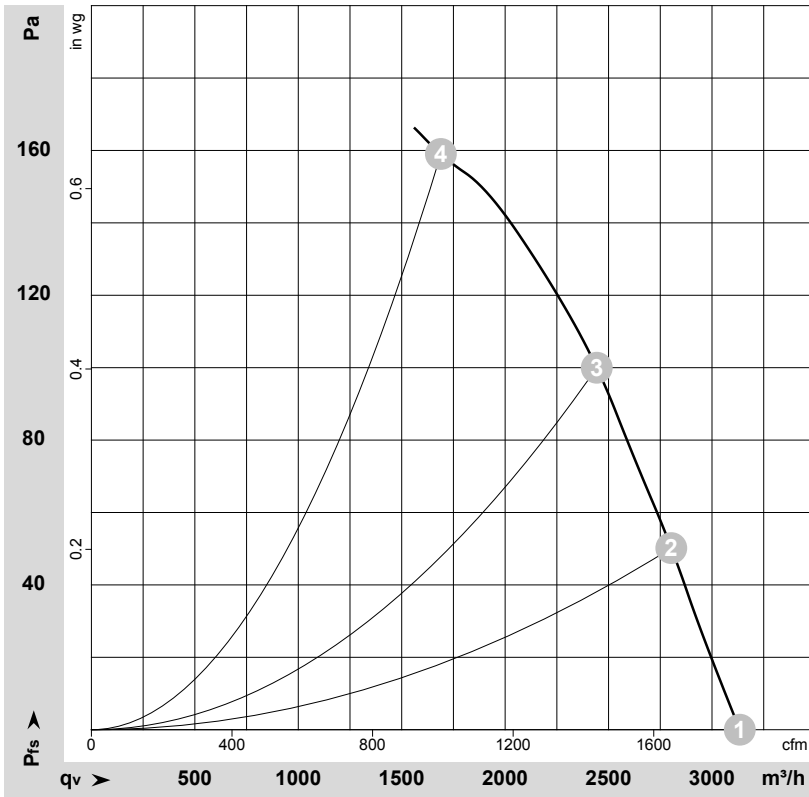

$\rho = 1.15 \text{ kg/m}^3 \pm 2 \%$

Measurement: LU-62732-1

Air performance measured as per ISO 5801 Installation category A. For detailed information on the measuring set-up, please contact ebmpapst. Suction-side noise levels: LwA measured as per ISO 13347 / LpA measured with 1m distance to fan axis. The values given are valid under the measuring conditions mentioned above and may vary according to the actual installation situation. With any deviation from the standard set-up, the specific values have to be checked and reviewed with the unit installed.

Measured values

	Conn.	U	f	n	P _e	I	q _v	p _{fs}	q _v	p _{fs}
		V	Hz	min ⁻¹	W	A	m ³ /h	Pa	cfm	in. wg
1	Y	400	50	2580	210	0.36	3135	0	1845	0.00
2	Y	400	50	2540	228	0.36	2805	50	1650	0.20
3	Y	400	50	2490	244	0.39	2445	100	1440	0.40
4	Y	400	50	2385	281	0.44	1690	160	995	0.64

Conn. = Connection · U = Supply voltage · f = Frequency · n = Speed (rpm) · P_e = Power input · I = Current draw · q_v = Air flow · p_e = Pressure increase



Charts: Air flow 60 Hz

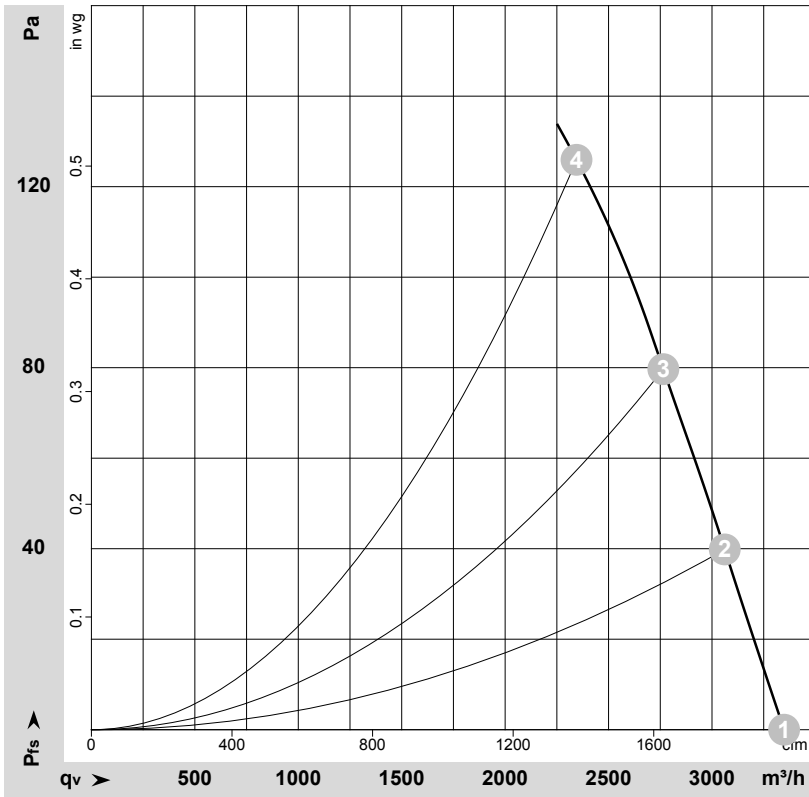

$\rho = 1.15 \text{ kg/m}^3 \pm 2 \%$

Measurement: LU-62733-1

Air performance measured as per ISO 5801 Installation category A. For detailed information on the measuring set-up, please contact ebmpapst. Suction-side noise levels: LwA measured as per ISO 13347 / LpA measured with 1m distance to fan axis. The values given are valid under the measuring conditions mentioned above and may vary according to the actual installation situation. With any deviation from the standard set-up, the specific values have to be checked and reviewed with the unit installed.

Measured values

	U	f	n	P _e	I	q _v	P _{fs}	q _v	P _{fs}
	V	Hz	min ⁻¹	W	A	m ³ /h	Pa	cfm	in. wg
1	400	60	2750	300	0.48	3350	0	1970	0.00
2	400	60	2685	316	0.48	3060	40	1800	0.16
3	400	60	2625	331	0.50	2765	80	1625	0.32
4	400	60	2540	349	0.53	2345	125	1380	0.50

U = Supply voltage · f = Frequency · n = Speed (rpm) · P_e = Power input · I = Current draw · q_v = Air flow · P_{fs} = Pressure increase

