

A2D300-AP02-19 ebmpapst Datasheet

sales@fansco.com

www.fansco.com

Limited partnership · Headquarters Muldingen

Amtsgericht (court of registration) Stuttgart · HRA 590344

General partner Elektrobau Muldingen GmbH · Headquarters Muldingen

Amtsgericht (court of registration) Stuttgart · HRB 590142



## Nominal data

Type	A2D300-AP02-19				
Motor	M2D074-DF				
Phase		3~	3~	3~	3~
Nominal voltage	VAC	230	230	400	400
Wiring		$\Delta$	$\Delta$	Y	Y
Frequency	Hz	50	60	50	60
Method of obtaining data		fa	fa	fa	fa
Valid for approval/standard		CE	CE	CE	CE
Speed (rpm)	min <sup>-1</sup>	2580	2750	2580	2750
Power consumption	W	210	300	210	300
Current draw	A	0.62	0.84	0.36	0.48
Max. back pressure	Pa	200	125	200	125
Max. back pressure	inH <sub>2</sub> O	0.8	0.5	0.8	0.5
Min. ambient temperature	°C	-25	-25	-25	-25
Max. ambient temperature	°C	75	40	75	40
Starting current	A	2.0	1.9	1.16	1.1

ml = Max. load · me = Max. efficiency · fa = Free air · cs = Customer specification · ce = Customer equipment  
Subject to change

## Data according to ErP Directive

		Actual	Req. 2015			
01 Overall efficiency $\eta_{es}$	%	29.9	29.9	09 Power consumption $P_e$	kW	0.25
02 Measurement category		A		09 Air flow $q_v$	m <sup>3</sup> /h	2210
03 Efficiency category		Static		09 Pressure increase $p_{fs}$	Pa	125
04 Efficiency grade N		40	40	10 Speed (rpm) n	min <sup>-1</sup>	2455
05 Variable speed drive		No		11 Specific ratio*		1.00

Data obtained at optimum efficiency level.  
The ErP data is determined using a motor-impeller combination in a standardized measurement setup.

\* Specific ratio =  $1 + p_g / 100\,000\text{ Pa}$ 

LU-62732



### Technical description

Weight	3.16 kg
Fan size	300 mm
Rotor surface	Painted black
Blade material	Sheet steel, painted black
Number of blades	5
Airflow direction	"V"
Direction of rotation	Counterclockwise, viewed toward rotor
Degree of protection	IP44
Insulation class	"F"
Moisture (F) / Environmental (H) protection class	H0+
Max. permitted ambient temp. for motor (transport/storage)	+ 80 °C
Min. permitted ambient temp. for motor (transport/storage)	- 40 °C
Installation position	Any
Condensation drainage holes	On rotor side
Mode	S1
Motor bearing	Ball bearing
Touch current according to IEC 60990 (measuring circuit Fig. 4, TN system)	< 0.75 mA
With cable	Variable
Protection class	I (with customer connection of protective earth)
Conformity with standards	EN 60335-1; CE

# AC axial fan

sickle-shaped blades (S series)

## Product drawing

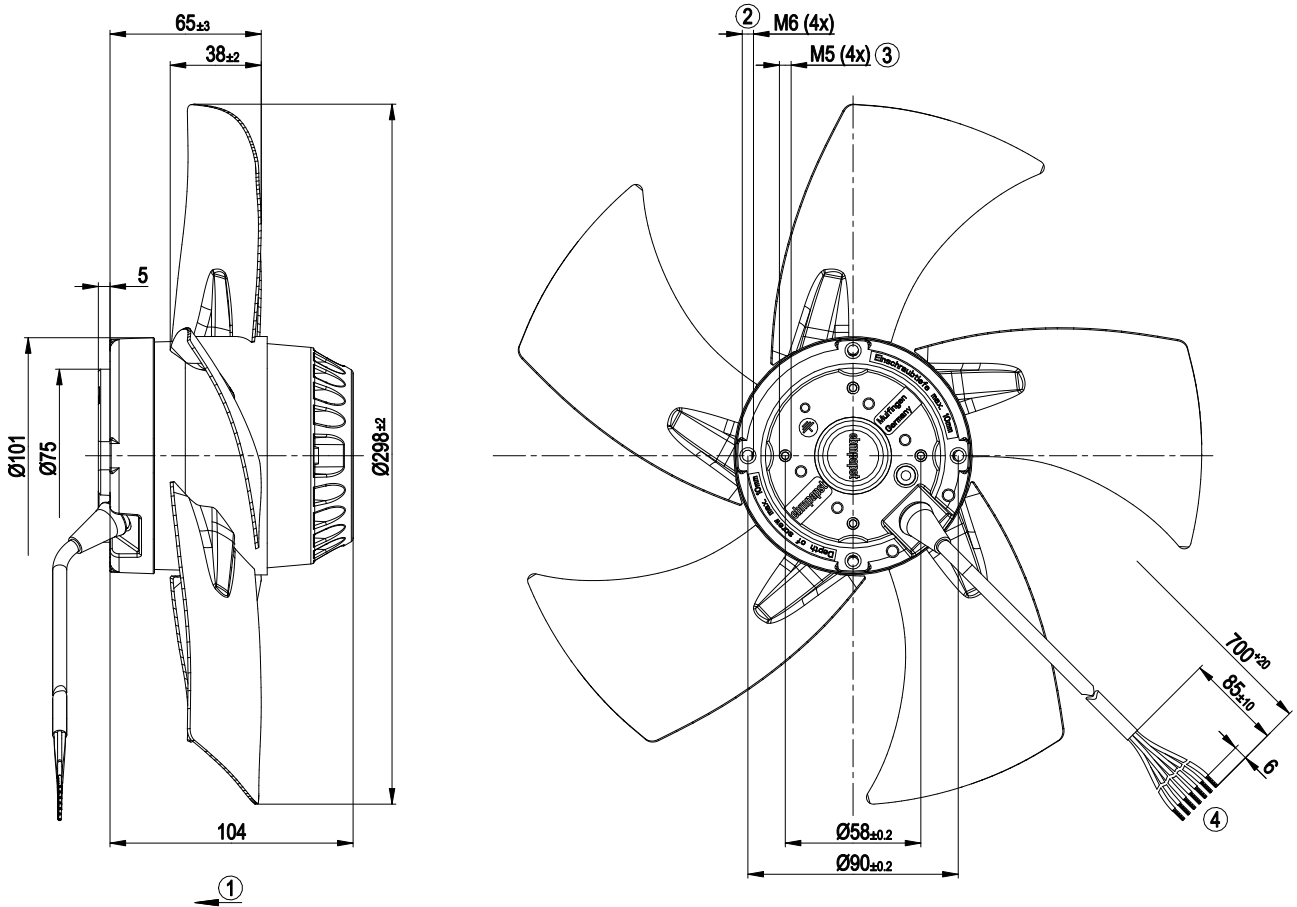

1	Direction of air flow "V"
2	Max. clearance for screw 10 mm
3	Max. clearance for screw 8 mm
4	Cable halogen-silicone-free 7G 0.5 mm <sup>2</sup> , 7x crimped splices



## Connection diagram

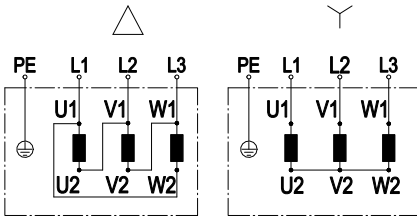

Change of rotation direction by reversing two phases

	Three-phase motor	Δ	Delta connection	Y	Star connection
L1	= U1 = black	L2	= V1 = blue	L3	= W1 = brown
U2	green	V2	white	W2	yellow
PE	green/yellow				

## Curves: Air performance 50 Hz

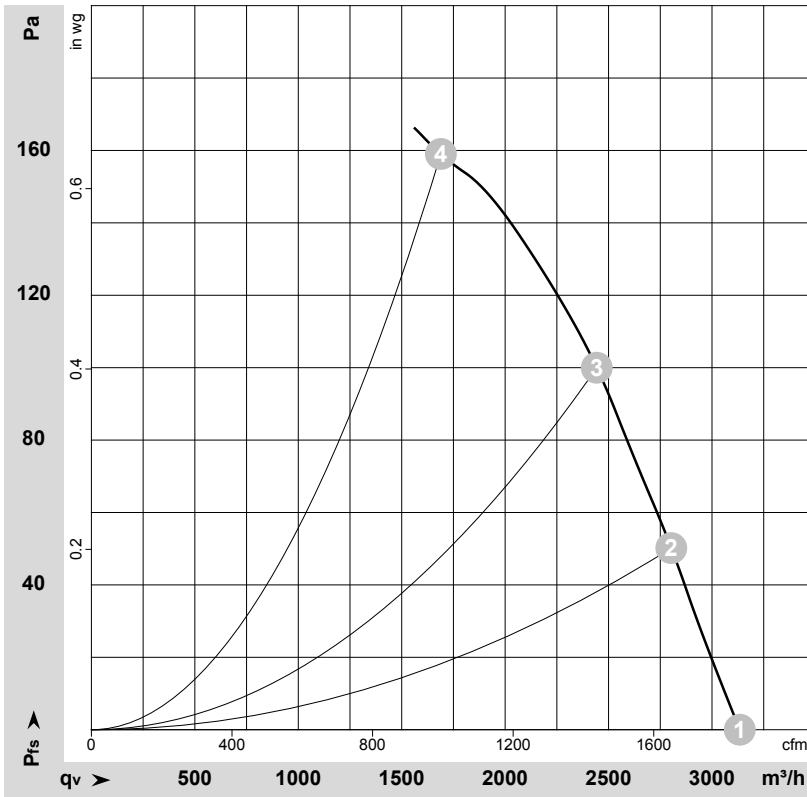

$\rho = 1.15 \text{ kg/m}^3 \pm 2 \%$

Measurement: LU-62732-1

Air performance measured according to ISO 5801 installation category A. For detailed information on the measurement setup, contact ebmpapst. Intake sound level: Sound power level according to ISO 13347 / sound pressure level measured at 1 m distance from fan axis. The values given are valid under the specified measuring conditions and may vary due to conditions of installation. For deviations from the standard configuration, the parameters have to be checked on the installed unit.

## Measured values

	Wired	U	f	n	P <sub>e</sub>	I	qv	p <sub>fs</sub>	qv	p <sub>fs</sub>
		V	Hz	min <sup>-1</sup>	W	A	m <sup>3</sup> /h	Pa	CFM	inH2O
1	Y	400	50	2580	210	0.36	3135	0	1845	0.00
2	Y	400	50	2540	228	0.36	2805	50	1650	0.20
3	Y	400	50	2490	244	0.39	2445	100	1440	0.40
4	Y	400	50	2385	281	0.44	1690	160	995	0.64

Wired = Wiring · U = Power supply · f = Frequency · n = Speed (rpm) · P<sub>e</sub> = Power consumption · I = Current draw · qv = Air flow · p<sub>fs</sub> = Pressure increase



## Curves: Air performance 60 Hz

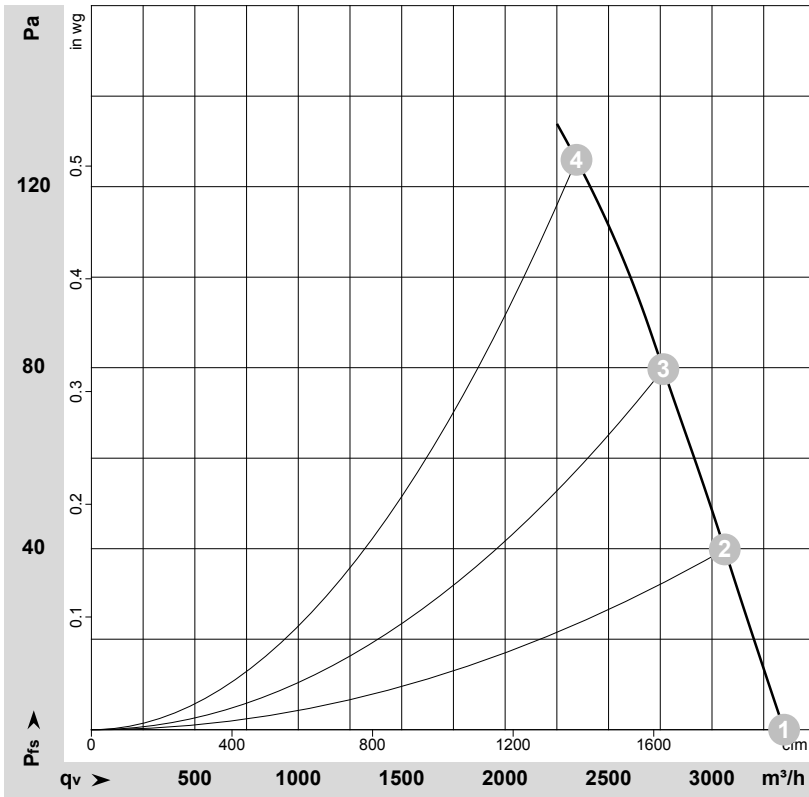

$\rho = 1.15 \text{ kg/m}^3 \pm 2 \%$

Measurement: LU-62733-1

Air performance measured according to ISO 5801 installation category A. For detailed information on the measurement setup, contact ebmpapst. Intake sound level: Sound power level according to ISO 13347 / sound pressure level measured at 1 m distance from fan axis. The values given are valid under the specified measuring conditions and may vary due to conditions of installation. For deviations from the standard configuration, the parameters have to be checked on the installed unit.

## Measured values

	U	f	n	P <sub>e</sub>	I	q <sub>v</sub>	p <sub>fs</sub>	q <sub>v</sub>	p <sub>fs</sub>
	V	Hz	min <sup>-1</sup>	W	A	m <sup>3</sup> /h	Pa	CFM	inH <sub>2</sub> O
1	400	60	2750	300	0.48	3350	0	1970	0.00
2	400	60	2685	316	0.48	3060	40	1800	0.16
3	400	60	2625	331	0.50	2765	80	1625	0.32
4	400	60	2540	349	0.53	2345	125	1380	0.50

U = Power supply · f = Frequency · n = Speed (rpm) · P<sub>e</sub> = Power consumption · I = Current draw · q<sub>v</sub> = Air flow · p<sub>fs</sub> = Pressure increase

