

# AC axial fan

sickled blades (S series)

A2D250-AI14-10 ebmpapst Datasheet  
 sales@fansco.com  
 www.fansco.com

Limited partnership · Headquarters Muldingen  
 County court Stuttgart · HRA 590344  
 General partner Elektrobau Muldingen GmbH · Headquarters Muldingen  
 County court Stuttgart · HRB 590142

## Nominal data

|                               |                       |      |      |      |      |      |      |      |      |      |      |
|-------------------------------|-----------------------|------|------|------|------|------|------|------|------|------|------|
| <b>Type</b>                   | <b>A2D250-AI14-10</b> |      |      |      |      |      |      |      |      |      |      |
| <b>Motor</b>                  | <b>M2D068-CC</b>      |      |      |      |      |      |      |      |      |      |      |
| Phase                         |                       | 3~   | 3~   | 3~   | 3~   | 3~   | 3~   | 3~   | 3~   | 3~   | 3~   |
| Nominal voltage               | VAC                   | 208  | 220  | 220  | 230  | 230  | 265  | 360  | 380  | 380  | 400  |
| Connection                    |                       | Δ    | Δ    | Δ    | Δ    | Δ    | Δ    | Y    | Y    | Y    | Y    |
| Frequency                     | Hz                    | 60   | 50   | 60   | 50   | 60   | 60   | 60   | 50   | 60   | 50   |
| Type of data definition       |                       | fa   | fa   | fa   | fa   | fa   | fa   | fa   | fa   | fa   | fa   |
| Valid for approval / standard |                       | CE   | CE   | CE   | CE   | CE   | CE   | CE   | CE   | CE   | CE   |
| Speed                         | min <sup>-1</sup>     | 2350 | 2370 | 2440 | 2460 | 2580 | 2750 | 2350 | 2370 | 2440 | 2460 |
| Power input                   | W                     | 128  | 102  | 135  | 110  | 140  | 160  | 128  | 102  | 135  | 110  |
| Current draw                  | A                     | 0.40 | 0.33 | 0.40 | 0.33 | 0.38 | 0.40 | 0.23 | 0.19 | 0.23 | 0.19 |
| Max. back pressure            | Pa                    | 84   | 93   | 93   | 100  | 100  | 120  | 84   | 93   | 93   | 100  |
| Min. ambient temperature      | °C                    | -25  | -25  | -25  | -25  | -25  | -25  | -25  | -25  | -25  | -25  |
| Max. ambient temperature      | °C                    | 60   | 80   | 60   | 80   | 60   | 60   | 60   | 80   | 60   | 80   |

ml = Max. load · me = Max. efficiency · fa = Running at free air · cs = Customer specs · cu = Customer unit  
 Subject to alterations



# AC axial fan

sickled blades (S series)

## Technical features

|   |   |
|---|---|
| <b>Mass</b>   | 1.9 kg  |
| <b>Size</b>   | 250 mm  |
| <b>Surface of rotor</b>   | Coated in black   |
| <b>Material of blades</b>   | Sheet steel, coated in black                                    |
| <b>Number of blades</b>   | 9   |
| <b>Direction of air flow</b>  | "A"   |
| <b>Direction of rotation</b>  | Counter-clockwise, seen on rotor                                |
| <b>Type of protection</b>   | IP 44; Depending on installation and position as per EN 60034-5 |
| <b>Insulation class</b>   | "F"   |
| <b>Humidity class</b>   | F2-2  |
| <b>Max. permissible ambient motor temp. (transp./ storage)</b>            | + 80 °C   |
| <b>Min. permissible ambient motor temp. (transp./storage)</b>             | - 40 °C   |
| <b>Mounting position</b>  | Shaft horizontal or rotor on bottom; rotor on top on request    |
| <b>Condensate discharge holes</b>   | Rotor-side  |
| <b>Operation mode</b>   | S1  |
| <b>Motor bearing</b>  | Ball bearing  |
| <b>Touch current acc. IEC 60990 (measuring network Fig. 4, TN system)</b> | < 0.75 mA   |
| <b>Cable exit</b>   | Axial   |
| <b>Protection class</b>   | I (if protective earth is connected by customer)                |
| <b>Product conforming to standard</b>                                     | EN 60335-1  |
| <b>Approval</b>   | CSA C22.2 Nr.100; UL 1004-1                                     |



Product drawing

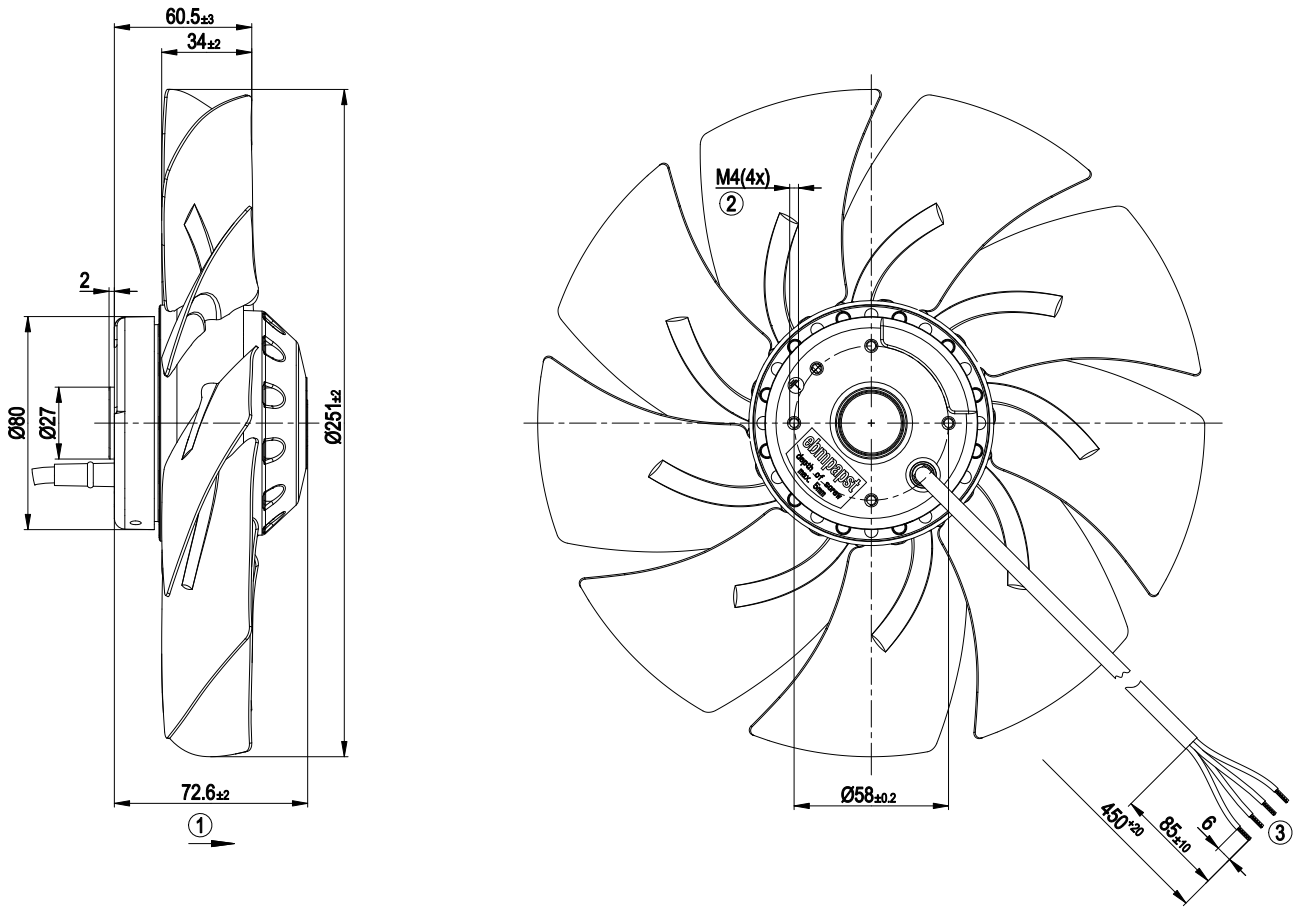

|   |  |
|---|--|
| 1 | Direction of air flow "A"                          |
| 2 | Depth of screw max. 5 mm                           |
| 3 | Connection line PFA 4G, 4x brass lead tips crimped |



## Connection screen

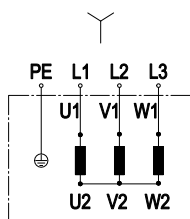

Change direction of rotation by reversing two phases

|    |                   |    |                 |    |              |
|----|-------------------|----|-----------------|----|--------------|
|    | Three-phase motor | Y  | Star connection | L1 | black        |
| L2 | blue              | L3 | brown           | PE | green/yellow |



## Charts: Air flow 50 Hz Y

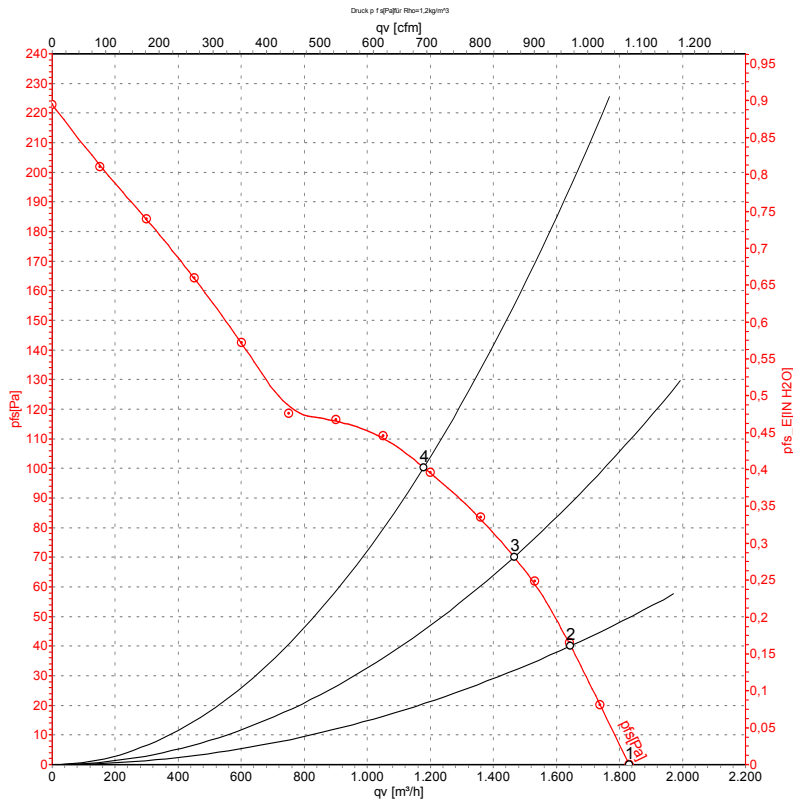

Measurement: LU-76487

Air performance measured as per ISO 5801 Installation category A. For detailed information on the measuring set-up, please contact ebmpapst. Suction-side noise levels: L<sub>wA</sub> measured as per ISO 13347 / L<sub>pA</sub> measured with 1m distance to fan axis. The values given are valid under the measuring conditions mentioned above and may vary according to the actual installation situation. With any deviation from the standard set-up, the specific values have to be checked and reviewed with the unit installed.

## Measured values

|   | Conn. | U   | f  | n                 | P <sub>e</sub> | I    | qv                | P <sub>fs</sub> |
|---|-------|-----|----|-------------------|----------------|------|-------------------|-----------------|
|   |       | V   | Hz | min <sup>-1</sup> | W              | A    | m <sup>3</sup> /h | Pa              |
| 1 | Y     | 400 | 50 | 2460              | 110            | 0.19 | 1830              | 0               |
| 2 | Y     | 400 | 50 | 2395              | 113            | 0.20 | 1645              | 40              |
| 3 | Y     | 400 | 50 | 2350              | 120            | 0.21 | 1465              | 70              |
| 4 | Y     | 400 | 50 | 2290              | 126            | 0.22 | 1180              | 100             |

Conn. = Connection · U = Supply voltage · f = Frequency · n = Speed · P<sub>e</sub> = Power input · I = Current draw · qv = Air flow · P<sub>fs</sub> = Pressure increase



## Charts: Air flow 60 Hz Y

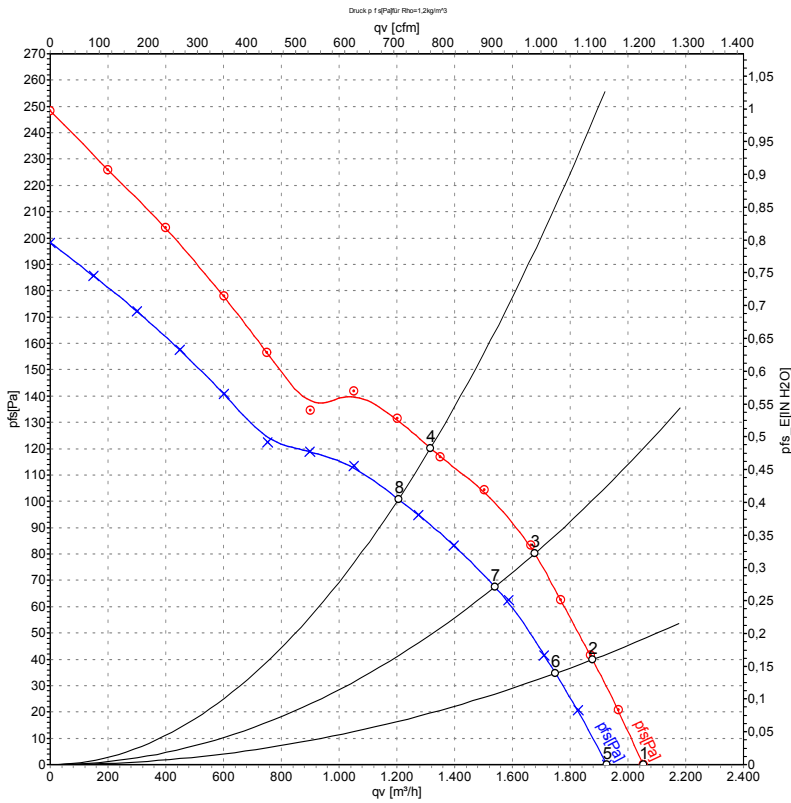

Measurement: LU-76489  
Measurement: LU-76488

Air performance measured as per ISO 5801 Installation category A. For detailed information on the measuring set-up, please contact ebmpapst. Suction-side noise levels: L<sub>WA</sub> measured as per ISO 13347 / L<sub>pA</sub> measured with 1m distance to fan axis. The values given are valid under the measuring conditions mentioned above and may vary according to the actual installation situation. With any deviation from the standard set-up, the specific values have to be checked and reviewed with the unit installed.

## Measured values

|   | Conn. | U   | f  | n                 | P <sub>e</sub> | I    | qv                | p <sub>fs</sub> |
|---|-------|-----|----|-------------------|----------------|------|-------------------|-----------------|
|   |       | V   | Hz | min <sup>-1</sup> | W              | A    | m <sup>3</sup> /h | Pa              |
| 1 | Y     | 460 | 60 | 2750              | 160            | 0.23 | 2055              | 0               |
| 2 | Y     | 460 | 60 | 2690              | 165            | 0.24 | 1875              | 40              |
| 3 | Y     | 460 | 60 | 2600              | 177            | 0.25 | 1675              | 80              |
| 4 | Y     | 460 | 60 | 2515              | 187            | 0.26 | 1315              | 120             |
| 5 | Y     | 400 | 60 | 2580              | 140            | 0.22 | 1925              | 0               |
| 6 | Y     | 400 | 60 | 2500              | 145            | 0.23 | 1750              | 35              |
| 7 | Y     | 400 | 60 | 2405              | 154            | 0.24 | 1540              | 68              |
| 8 | Y     | 400 | 60 | 2310              | 161            | 0.26 | 1205              | 100             |

Conn. = Connection · U = Supply voltage · f = Frequency · n = Speed · P<sub>e</sub> = Power input · I = Current draw · qv = Air flow · p<sub>fs</sub> = Pressure increase

