

A2D250-AH02-10 ebmpapst Datasheet

sales@fansco.com

www.fansco.com

Limited partnership · Headquarters Mulfingen

Amtsgericht (court of registration) Stuttgart · HRA 590344

General partner Elektrobau Mulfingen GmbH · Headquarters Mulfingen

Amtsgericht (court of registration) Stuttgart · HRB 590142

## Nominal data

Type	A2D250-AH02-10		
Motor	M2D068-CC		
Phase		3~	3~
Nominal voltage	VAC	400	400
Wiring		Y	Y
Frequency	Hz	50	60
Method of obtaining data		fa	fa
Valid for approval/standard		CE	CE
Speed (rpm)	min <sup>-1</sup>	2500	2650
Power consumption	W	105	145
Current draw	A	0.19	0.23
Max. back pressure	Pa	150	150
Max. back pressure	inH <sub>2</sub> O	0.6	0.6
Min. ambient temperature	°C	-25	-25
Max. ambient temperature	°C	60	60

ml = Max. load · me = Max. efficiency · fa = Free air · cs = Customer specification · ce = Customer equipment

Subject to change



### Technical description

Weight	1.9 kg
Fan size	250 mm
Rotor surface	Painted black
Blade material	Sheet steel, painted black
Number of blades	7
Airflow direction	"V"
Direction of rotation	Counterclockwise, viewed toward rotor
Degree of protection	IP54
Insulation class	"F"
Moisture (F) / Environmental (H) protection class	F5
Max. permitted ambient temp. for motor (transport/storage)	+ 80 °C
Min. permitted ambient temp. for motor (transport/storage)	- 40 °C
Installation position	Shaft horizontal or rotor on bottom; rotor on top on request
Condensation drainage holes	On rotor side
Mode	S1
Motor bearing	Ball bearing
Touch current according to IEC 60990 (measuring circuit Fig. 4, TN system)	< 0.75 mA
Motor protection	Thermal overload protector (TOP) with basic insulation
With cable	Lateral
Protection class	I (with customer connection of protective earth)
Conformity with standards	EN 60335-1; CE

## Product drawing

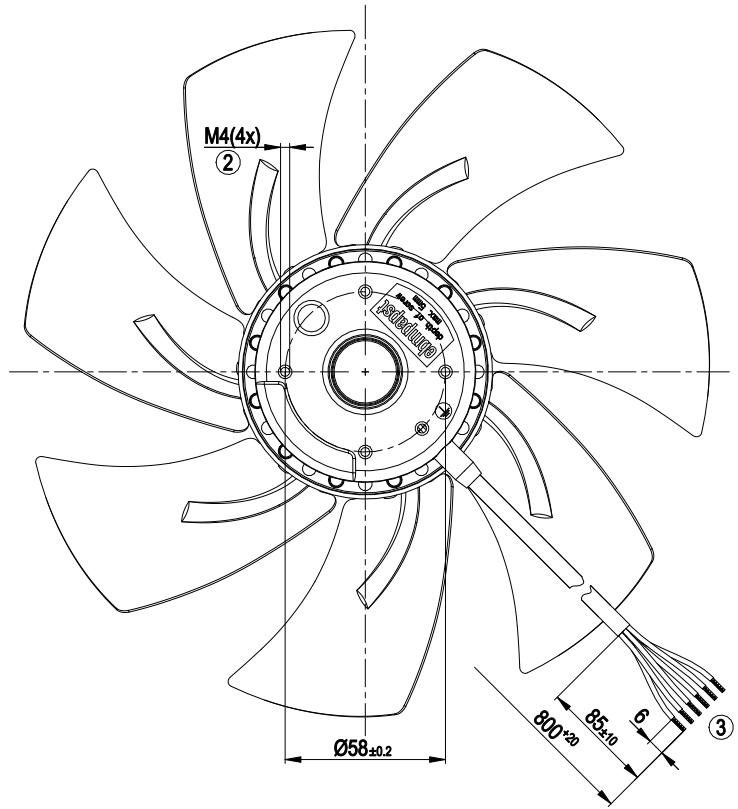
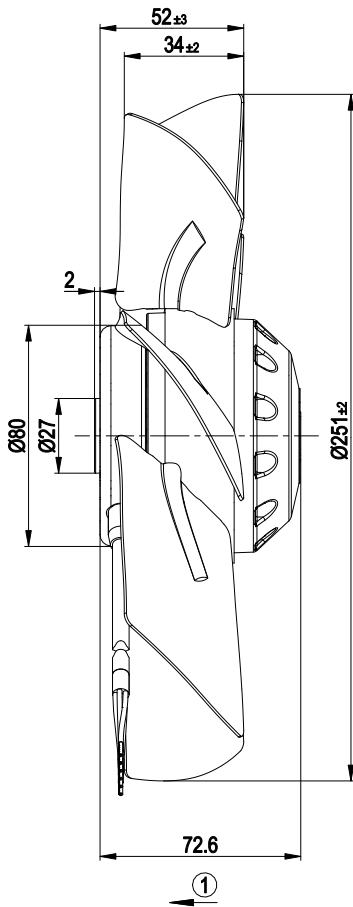

1	Direction of air flow "V"
2	Max. clearance for screw 5 mm
3	Cable silicone 6G 0.5 mm <sup>2</sup> , 6x crimped splices

## Connection diagram

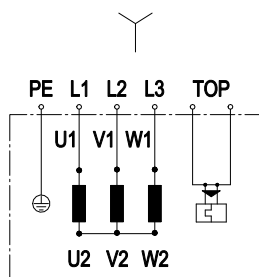

Note: Change of rotation direction by reversing two phases

Y	Star connection	L1	= U1 = black	L2	= V1 = blue
L3	= W1 = brown	PE	green/yellow	TOP	2x gray

## Curves: Air performance 50 Hz

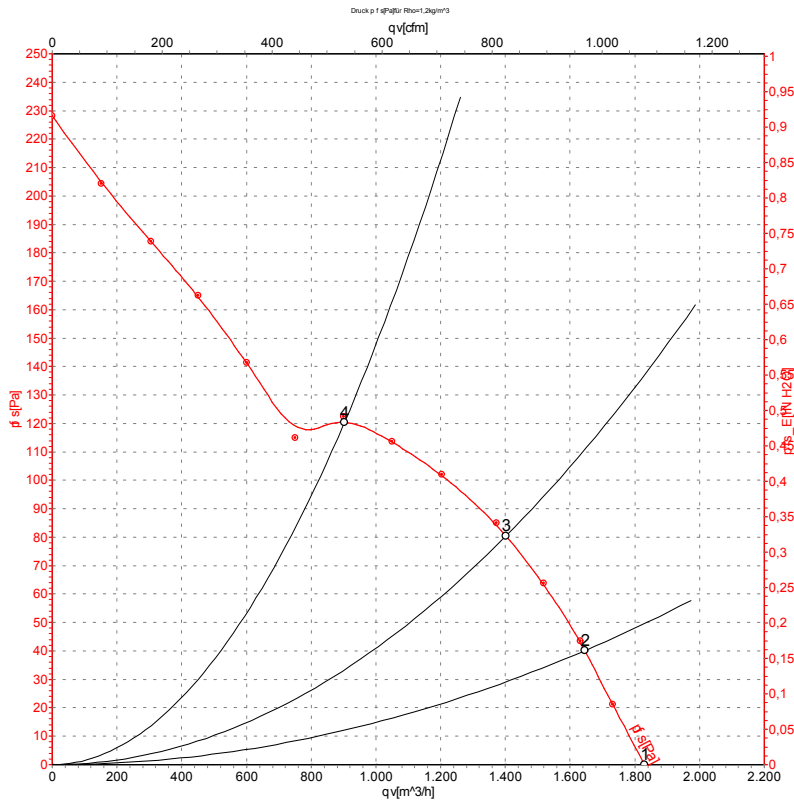

Measurement: LU-59965-1

Air performance measured according to ISO 5801 installation category A. For detailed information on the measurement setup, contact ebm-papst. Intake sound level: Sound power level according to ISO 13347 / sound pressure level measured at 1 m distance from fan axis. The values given are valid under the specified measuring conditions and may vary due to conditions of installation. For deviations from the standard configuration, the parameters have to be checked on the installed unit.

## Measured values

	U	f	n	P <sub>e</sub>	I	qv	p <sub>fs</sub>	qv	p <sub>fs</sub>
	V	Hz	min <sup>-1</sup>	W	A	m <sup>3</sup> /h	Pa	CFM	inH <sub>2</sub> O
1	400	50	2500	100	0.20	1830	0	1075	0.00
2	400	50	2425	111	0.21	1645	40	970	0.16
3	400	50	2360	120	0.21	1400	80	825	0.32
4	400	50	2310	127	0.22	905	122	530	0.49

U = Power supply · f = Frequency · n = Speed (rpm) · P<sub>e</sub> = Power consumption · I = Current draw · qv = Air flow · p<sub>fs</sub> = Pressure increase



## Curves: Air performance 60 Hz

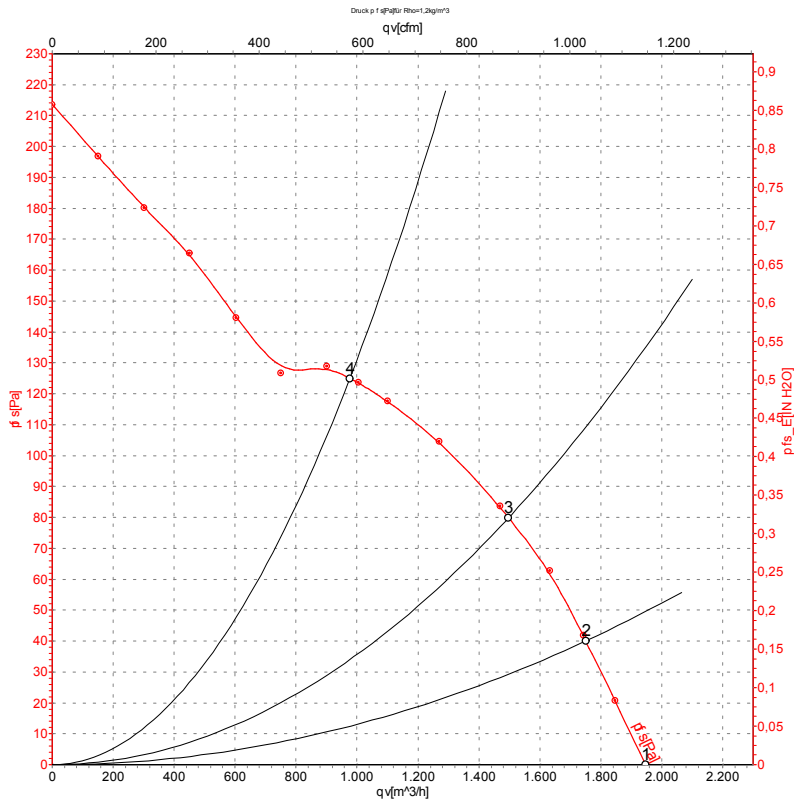

Measurement: LU-59966-1

Air performance measured according to ISO 5801 installation category A. For detailed information on the measurement setup, contact ebm-papst. Intake sound level: Sound power level according to ISO 13347 / sound pressure level measured at 1 m distance from fan axis. The values given are valid under the specified measuring conditions and may vary due to conditions of installation. For deviations from the standard configuration, the parameters have to be checked on the installed unit.

## Measured values

	U	f	n	$P_e$	I	$q_v$	$p_{fs}$	$q_v$	$p_{fs}$
	V	Hz	min <sup>-1</sup>	W	A	m³/h	Pa	CFM	inH2O
1	400	60	2650	140	0.23	1950	0	1150	0.00
2	400	60	2545	148	0.24	1750	40	1030	0.16
3	400	60	2450	158	0.25	1495	80	880	0.32
4	400	60	2350	166	0.26	975	125	575	0.50

U = Power supply · f = Frequency · n = Speed (rpm) ·  $P_e$  = Power consumption · I = Current draw ·  $q_v$  = Air flow ·  $p_{fs}$  = Pressure increase

