

AC axial fan

straight blades (A series)

A2D250-AA26-51 ebmpapst Datasheet

sales@fansco.com

www.fansco.com

Nominal data

Type	A2D250-AA26-51		
Motor	M2D068-DF		
Phase		3~	3~
Nominal voltage	VAC	400	400
Wiring		Y	Y
Frequency	Hz	50	60
Method of obtaining data		fa	fa
Valid for approval/standard		CE	CE
Speed (rpm)	min ⁻¹	2670	2900
Power consumption	W	125	175
Current draw	A	0.25	0.30
Max. back pressure	Pa	200	200
Max. back pressure	in. wg	0.8	0.8
Min. ambient temperature	°C	-25	-25
Max. ambient temperature	°C	70	50

ml = Max. load · me = Max. efficiency · fa = Free air · cs = Customer specification · ce = Customer equipment
 Subject to change



Technical description

Weight	2.02 kg
Fan size	250 mm
Rotor surface	Painted black
Blade material	Sheet steel, painted black
Number of blades	5
Airflow direction	"A"
Direction of rotation	Clockwise, viewed toward rotor
Degree of protection	IP44; installation- and position-dependent as per EN 60034-5
Insulation class	"B"
Moisture (F) / Environmental (H) protection class	H1
Max. permitted ambient temp. for motor (transport/storage)	+ 80 °C
Min. permitted ambient temp. for motor (transport/storage)	- 40 °C
Installation position	Shaft horizontal or rotor on bottom; rotor on top on request
Condensation drainage holes	On rotor side
Mode	S1
Motor bearing	Ball bearing
Touch current according to IEC 60990 (measuring circuit Fig. 4, TN system)	< 0.75 mA
With cable	Lateral
Protection class	I (with customer connection of protective earth)
Conformity with standards	EN 60335-1; CE
Approval	EAC

Product drawing

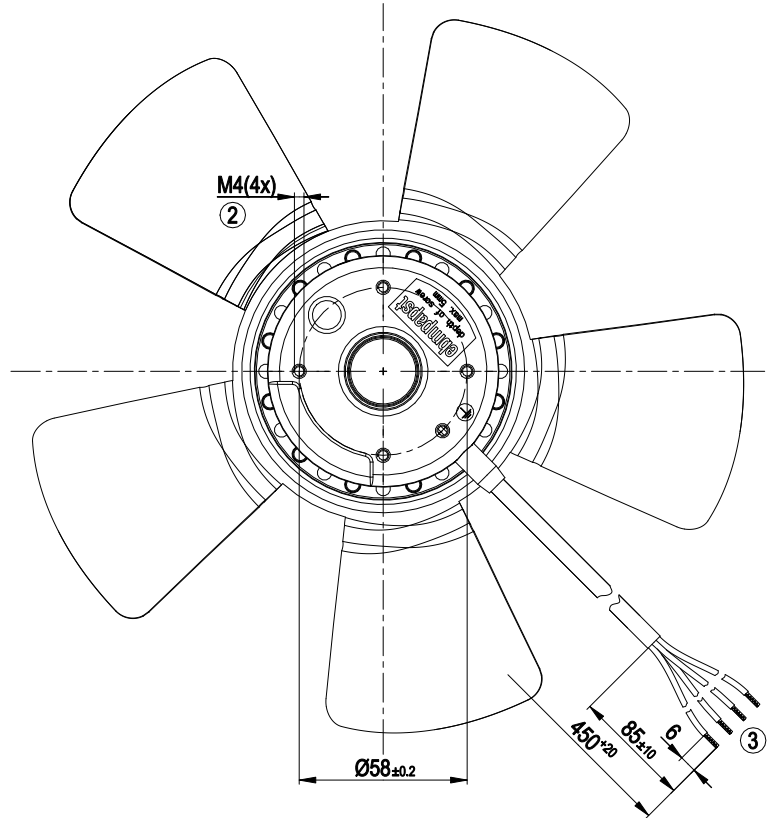
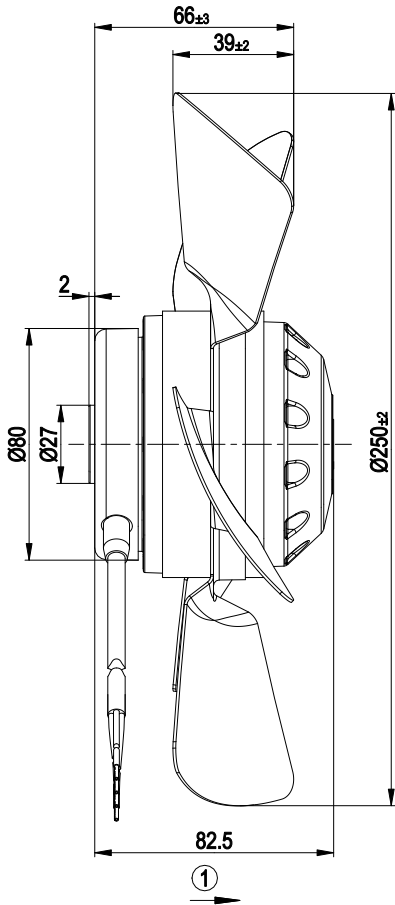

1	Direction of air flow "A"
2	Max. clearance for screw 5 mm
3	Cable PVC 4G 0.5 mm ² , 4x crimped splices



Connection diagram

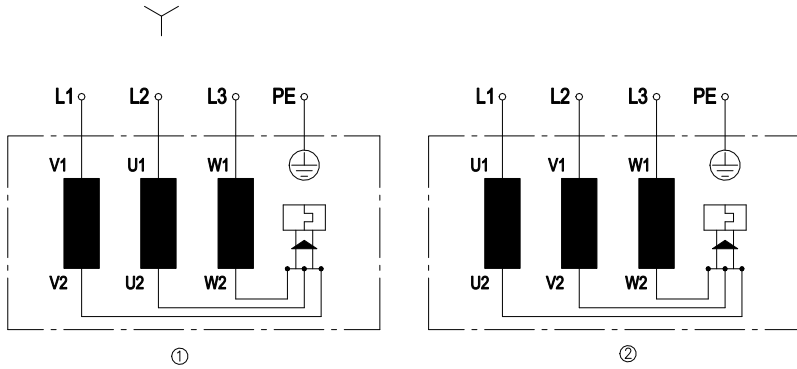

Change of rotation direction by reversing two phases

	Three-phase motor
Y	Star connection
1	Counterclockwise operation
L1	= V1 = blue
L2	= U1 = black
L3	= W1 = brown
2	Clockwise operation
L1	=U1=black
L2	=V1=blue
L3	=W1=brown
PE	green/yellow



Curves: Air performance 50 Hz

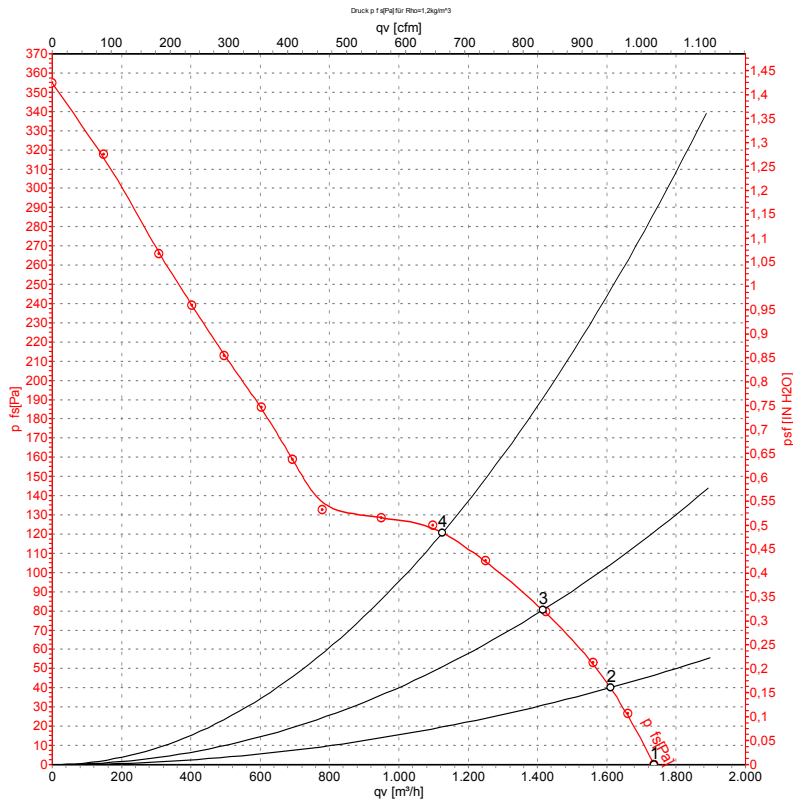

Measurement: LU-61000-1

Air performance measured according to ISO 5801 installation category A. For detailed information on the measurement setup, contact ebm-papst. Intake sound level: Sound power level according to ISO 13347 / sound pressure level measured at 1 m distance from fan axis. The values given are valid under the specified measuring conditions and may vary due to conditions of installation. For deviations from the standard configuration, the parameters have to be checked on the installed unit.

Measured values

	U	f	n	P _e	I	q _v	P _{fs}	q _v	P _{fs}
	V	Hz	min ⁻¹	W	A	m ³ /h	Pa	cfm	in. wg
1	400	50	2670	125	0.25	1735	0	1020	0.00
2	400	50	2620	127	0.25	1610	40	950	0.16
3	400	50	2590	133	0.25	1415	80	835	0.32
4	400	50	2590	136	0.25	1125	120	665	0.48

U = Power supply · f = Frequency · n = Speed (rpm) · P_e = Power consumption · I = Current draw · q_v = Air flow · P_{fs} = Pressure increase



Curves: Air performance 60 Hz

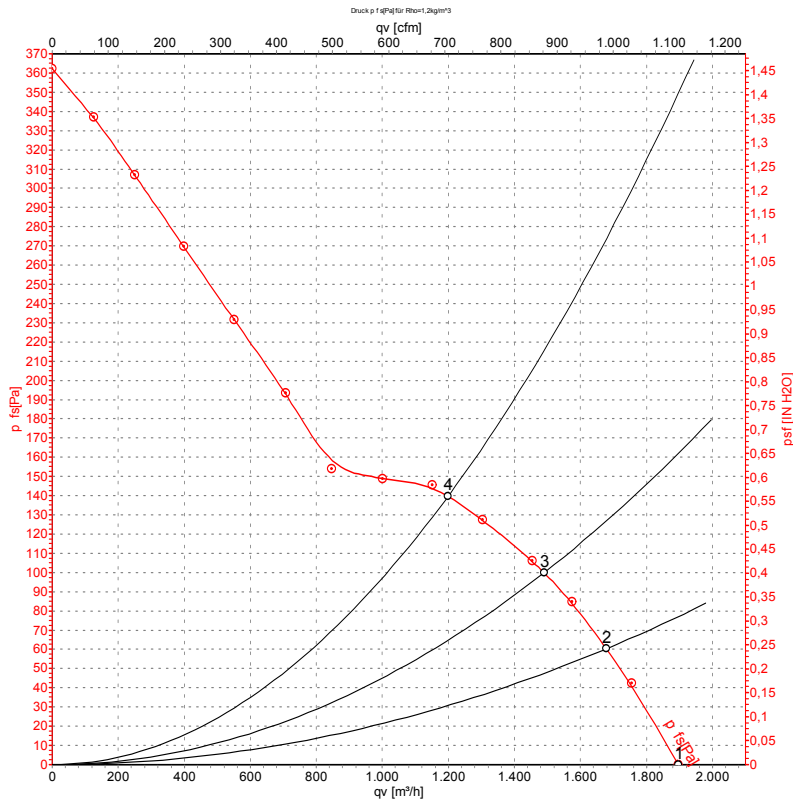

Measurement: LU-61001-1

Air performance measured according to ISO 5801 installation category A. For detailed information on the measurement setup, contact ebm-papst. Intake sound level: Sound power level according to ISO 13347 / sound pressure level measured at 1 m distance from fan axis. The values given are valid under the specified measuring conditions and may vary due to conditions of installation. For deviations from the standard configuration, the parameters have to be checked on the installed unit.

Measured values

	U	f	n	P _e	I	q _v	p _{fs}	q _v	p _{fs}
	V	Hz	min ⁻¹	W	A	m ³ /h	Pa	cfm	in. wg
1	400	60	2900	175	0.30	1895	0	1115	0.00
2	400	60	2825	182	0.30	1680	60	990	0.24
3	400	60	2800	188	0.30	1490	100	875	0.40
4	400	60	2790	190	0.30	1200	140	705	0.56

U = Power supply · f = Frequency · n = Speed (rpm) · P_e = Power consumption · I = Current draw · q_v = Air flow · p_{fs} = Pressure increase

